

## Technical Specifications

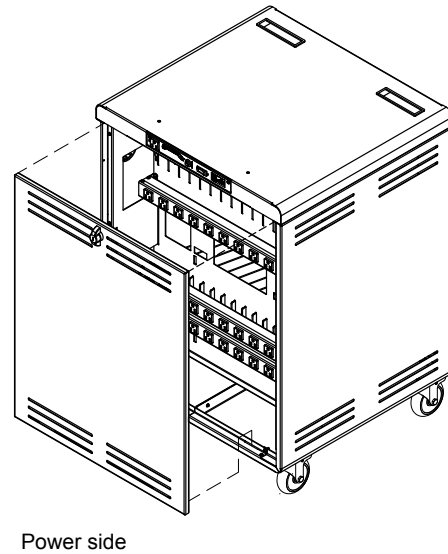

Use the Connect30 Cart to store, transport, and charge up to 30 tablets, Chromebooks or notebooks. A current-sensing PowerProdigy™ charging system is available if current requirements exceed 10 amps. Flexible dividers protect the devices. The overhead wire management aids the wiring integration and allows the charging plugs to hang in front of each device. The cart's compact footprint and top handles provide easy mobility. The Connect30 Cart is made with heavy-gauge steel for security and powder-coated for a durable, long-lasting finish. Locking door and panel increase security of the notebooks.

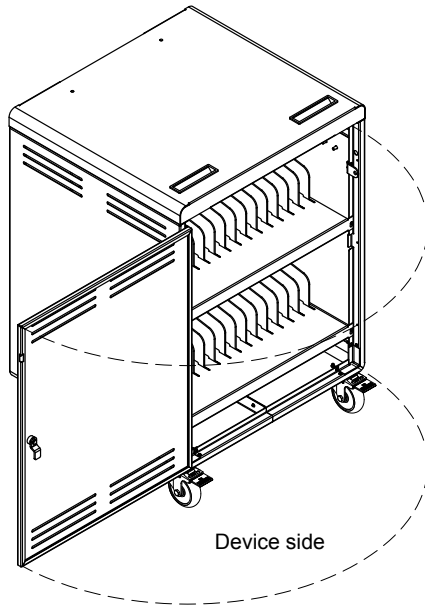

## Features and Benefits

- Stores, charges, and transports up to 30 devices (most tablets, Chromebooks, or notebooks up to 14" diagonal)
- 1.349"W x 15.675"D x 11.2875"H storage bay
- Small cart footprint (26"W x 24"D) saves valuable space
- Durable ABS plastic dividers protect devices from scratching (dividers are removable to provide storage space for thicker devices)
- Single keyed locks and heavy-gauge steel door and panel provide security
- Integrated padlock hasp in the hinged door provides an additional level of security and the ability to use your padlock of choice (not included), or secure the unit to a wall
- Devices and students are separated from AC line voltage
- Superior, all-metal overhead cord management system keeps charge cords organized above each bay
- Available with Intuitive PowerProdigy™ charging system that senses current from three, 10-outlet power units and distributes power (up to 10A) to the least-charged devices first (where charging is needed most) **\*For power adapters over 40 watts**
- Available with power switch which provides continuous power to all three 10-outlet power units (non current-sensing) **\*For power adapters up to 40 watts**
- Three horizontally adjustable, 10-outlet, (125V~/12A, 60Hz) universal power units work with both inline, and wall adapters
- External power switch provides easy-access for safe power connection / disconnection
- 2 aux outlets (always on) for teacher laptop, WiFi access point, or other accessory (1 external, 1 internal)
- Optional large removable QuickBrick™ wiring trays with retaining straps for inline charge adapters allow wiring to be completed outside the cart at the comfort of a workstation or desk to provide quick and easy integration
- Ventilated door and side panels keep devices and chargers cool, preventing overheating, and extending device life
- Replaceable, IEC (quick-release) 15' nominal 14 AWG, 3-wire power cord and external cord wrap brackets provide easy power access
- Four inboard 4" total locking balloon wheel plate casters with metal construction and non-marring rubber provide easy rolling, and quiet transport (rated for 250 lb each)
- Inset handles in top panel provide control and maneuverability
- Cart ships fully-assembled for quick, simple integration and deployment
- Durable powder coated steel chassis provides a long-lasting finish
- ETL recognized (certified to UL 60950-1) in the US and Canada for the cart and electrical system
- Warranted to be free of all defects in materials and workmanship for 10 years, electrical system 2 years
- Designed and manufactured in Chippewa Falls, WI, USA

Note: This cart is designed to hold up to 30 devices. The PowerProdigy™ should be used with power adapters over 40 watts. The power switch can be used with power adapters up to 40 watts.

### Configured Options

- **55473-CAA**  
with Power Switch - no trays
- **55473-CAB**  
with Power Switch - 3 QuickBrick™ wiring trays
- **55473-CAD**  
with PowerProdigy™ charger - 3 QuickBrick™ wiring trays

**55473 - C A D**

**Parent Number**

**Electrical:**  
 A = Power Switch - no Trays  
 B = Power Switch (Quickbrick™ trays included)  
 D = PowerProdigy™ Charger (Quickbrick™ trays included)

**Casters:**  
 A = 4" Balloon Wheel

**Color:**  
 C = Warm Gray Metal

### Color Options

**Metal:**  
 Warm Gray



## Construction

- 16-gauge side panels, shelves, door, and panel
- All metal components are finished with a scratch-resistant powder coat epoxy
- This cart is factory-assembled, packaged, and shipped on its own skid

## Specifications

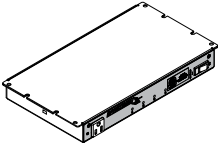
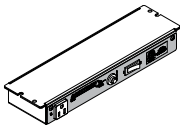

205 Westwood Ave, Long Branch, NJ 07740  
 Phone: 866-94 BOARDS (26273) / (732)-222-1511  
 Fax: (732)-222-7088 | E-mail: sales@touchboards.com

Capacity	30 Chromebooks, Tablets, or Notebooks	
Storage bays (nominal)	1.349"W [3.42 cm] x 15.675"D [39.81 cm] x 11.2875"H [28.67 cm]	
Electrical	<ul style="list-style-type: none"> <li>• (3) 10-outlet power units (outlets rotated 90°)</li> <li>• 125V~/12A, 60Hz</li> <li>• 15-amp breaker</li> <li>• IEC quick-release (replaceable) 15' nominal, 14 AWG, 3-wire power cord</li> </ul>	<ul style="list-style-type: none"> <li>• Locking power-side panel isolates and separates electrical line voltage from students</li> <li>• ETL recognized (certified to 60950-1)</li> </ul>
PowerProdigy™ Charger	 <ul style="list-style-type: none"> <li>• Low-profile, 16-gauge steel enclosure</li> <li>• 125V~/12A, 60Hz</li> <li>• Externally-accessible 15A on/off switch</li> <li>• Smart charging senses current and distributes power to the power units requiring it most</li> <li>• Four timed power unit-dedicated outlets (labeled A, B, C, D) controlled by logic board (up to 10A power output)</li> </ul>	<ul style="list-style-type: none"> <li>• Cycling interval 15 min</li> <li>• Four LED lights indicate charging activity status of each power unit</li> <li>• Two auxiliary outlets (1 external, 1 internal) 1A each (controlled by main on/off switch)</li> <li>• IEC quick-release (replaceable) 15' nominal, 14 AWG, 3-wire power cord</li> <li>• ETL recognized (certified to 60950-1)</li> </ul>
Power Switch (non current-sensing)	 <ul style="list-style-type: none"> <li>• Low-profile, 16-gauge steel enclosure</li> <li>• 125V~/12A, 60Hz</li> <li>• Externally-accessible 20A power switch</li> <li>• Four continuous power unit-dedicated outlets (labeled A, B, C, D) (up to 10A power output)</li> </ul>	<ul style="list-style-type: none"> <li>• Two auxiliary outlets (1 external, 1 internal) 1A each (controlled by main on/off switch)</li> <li>• IEC quick-release (replaceable) 15' nominal, 14 AWG, 3-wire power cord</li> <li>• ETL recognized (certified to 60950-1)</li> </ul>
<p>Note: The customer should be aware of the amp draw of the devices used with this cart-especially when maxing out the storage and charging capacity. Exceeding 15 amps will trip the circuit breaker. Please consult the owners manual of your specific device for power consumption information.</p>		
4" Balloon Wheels	Total locking Weight capacity 250 lb [113.5 kg] each	
Certifications / Compliance	<ul style="list-style-type: none"> <li>• ETL recognized</li> <li>• TAA compliant</li> </ul>	<ul style="list-style-type: none"> <li>• Meets or exceeds applicable ANSI-BIFMA test standards</li> </ul>
Unit weight (nominal)	150 lb [68.1 kg]	
Shipping weight (nominal)	170 lb [77.2 kg]	

Specifications subject to change without notice

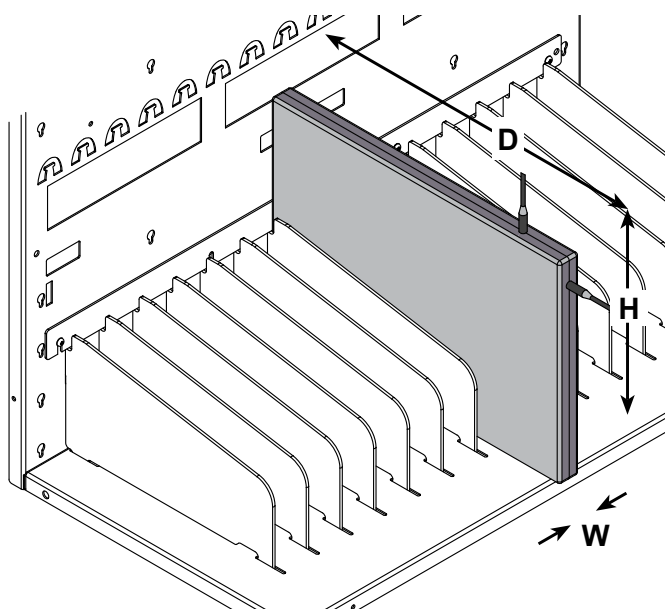

Notebooks / laptops must be placed in the bays with the charge plug on one of the two exposed edges shown.

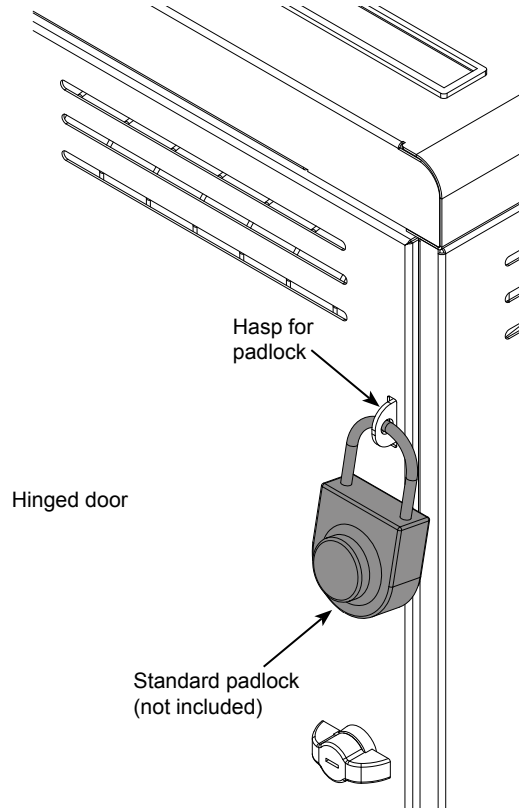

4" Balloon Wheel

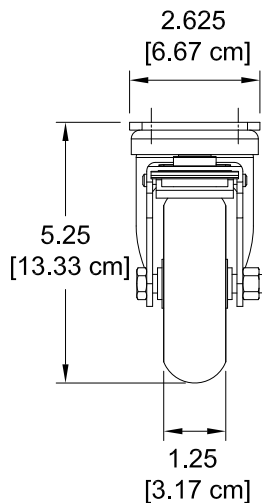
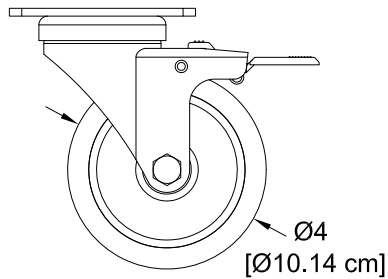
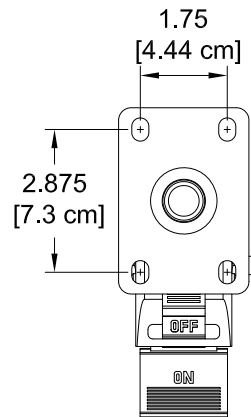
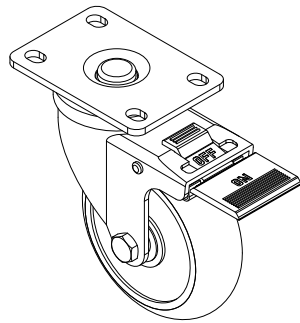

# Configured Options

## Product number breakdown

**55473 - C A D**

**Parent Number**

**Electrical:**

- A = Power Switch - no Trays
- B = Power Switch  
(Quickbrick™ trays included)
- D = PowerProdigy™ Charger  
(Quickbrick™ trays included)

**Casters:**

- A = 4" Balloon Wheel

**Color:**

- C = Warm Gray Metal

### Electrical Options

**ORDER CODE D = PowerProdigy™ Charger**

(see p.11 for specs)

On the Connect30, the PowerProdigy™ Charger should be used with power adapters 40 watts and greater.

**ORDER CODE A = No Trays**

**ORDER CODE B = Power Switch (with Quickbrick™ Trays)**

(Non current-sensing)

On the Connect30, the Power Switch can be used with power adapters up to 40 watts.

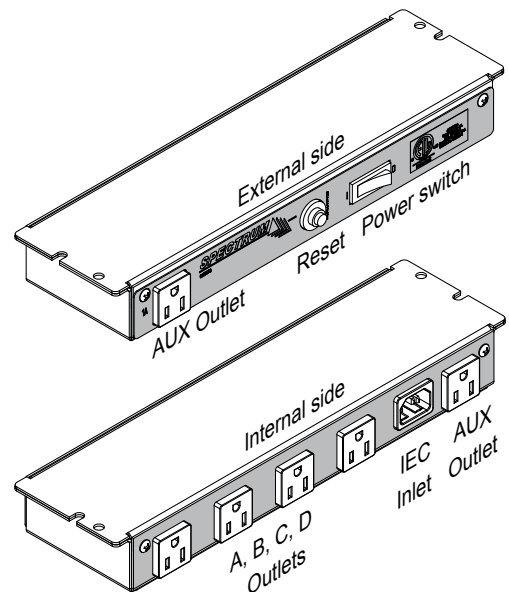
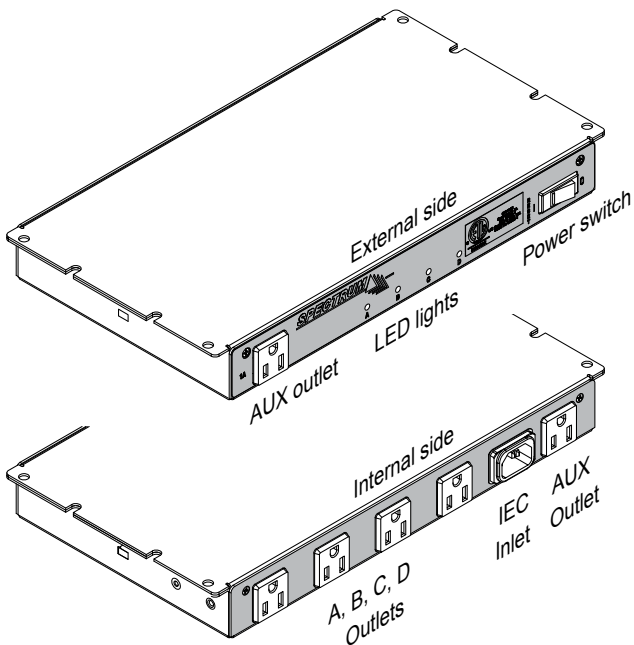

Connect30 Cart

Locking power-side panel

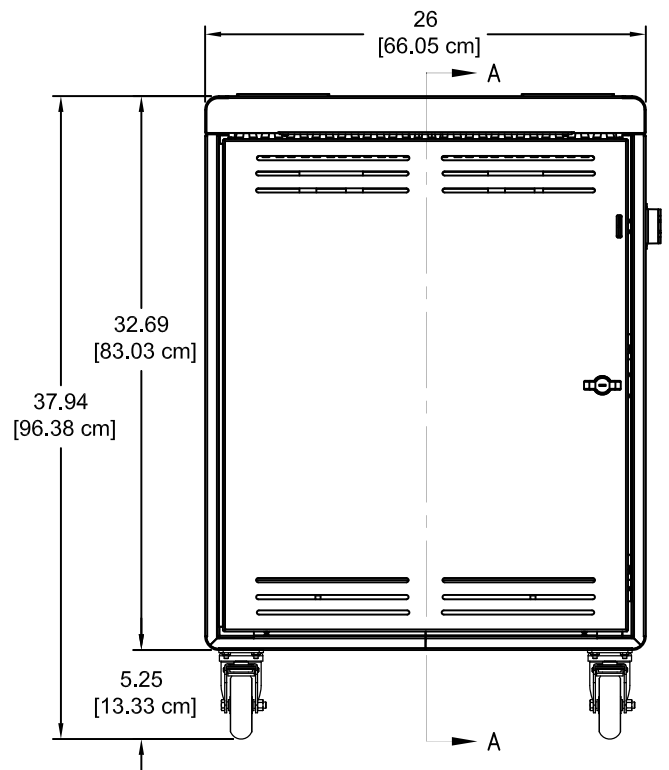
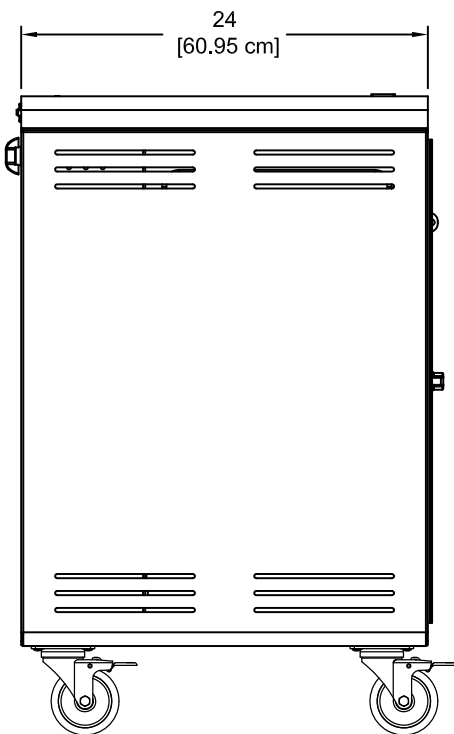
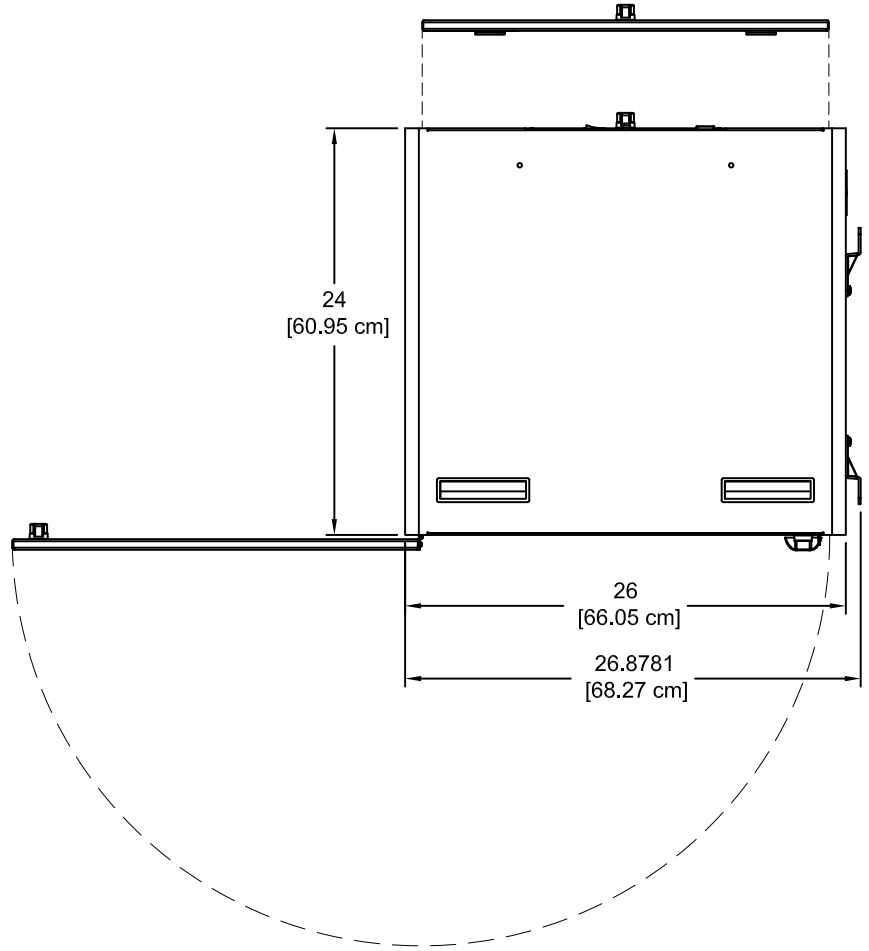
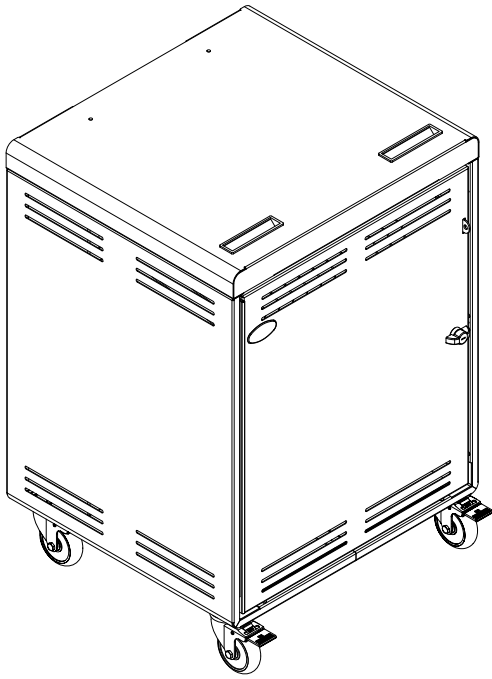

Connect30  
Section view A-A

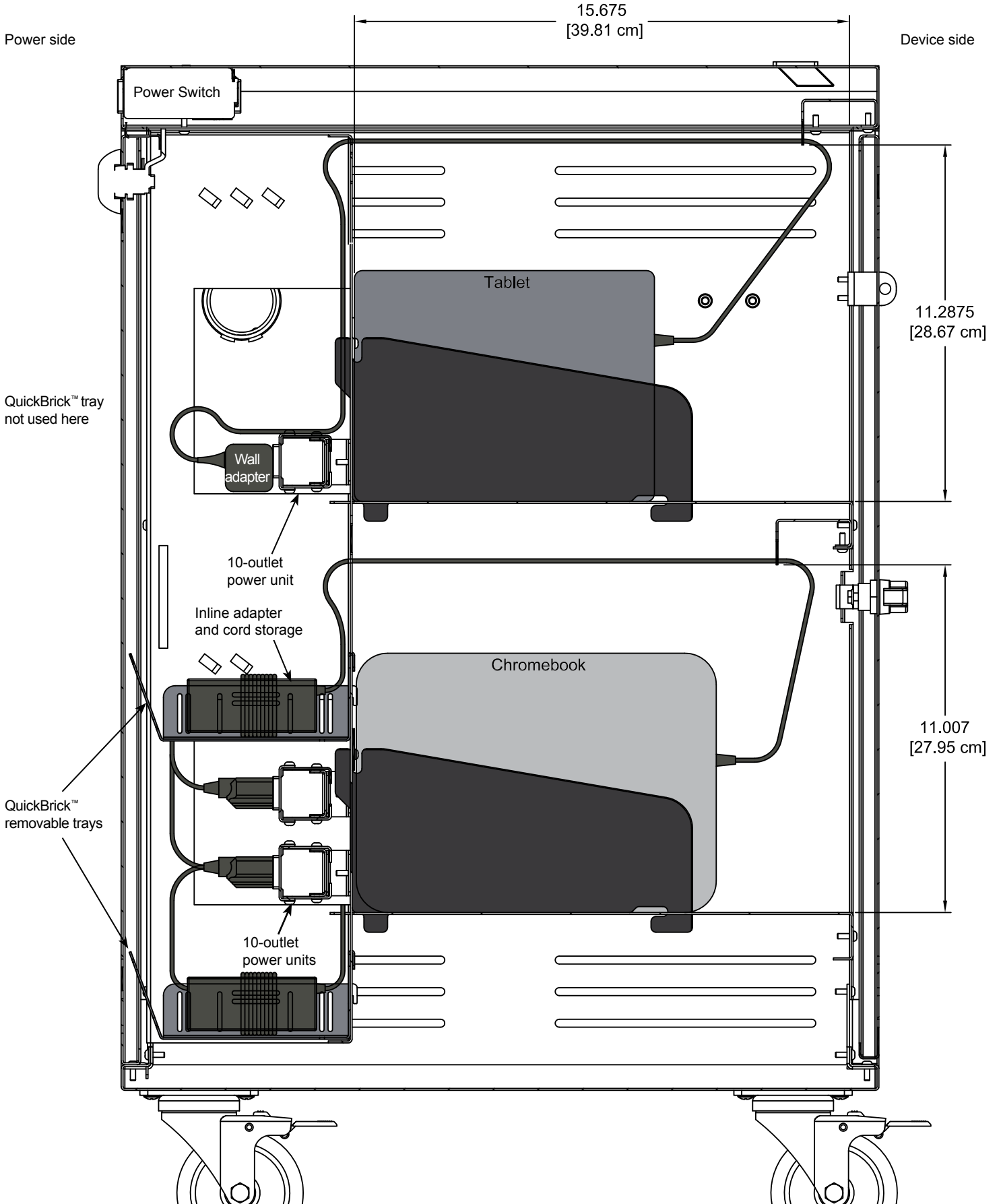

Connect30  
Device side view wiring diagram  
(shown without door)

1.349  
[3.42 cm]

Overhead cord management

Cord wraps

Overhead cord management

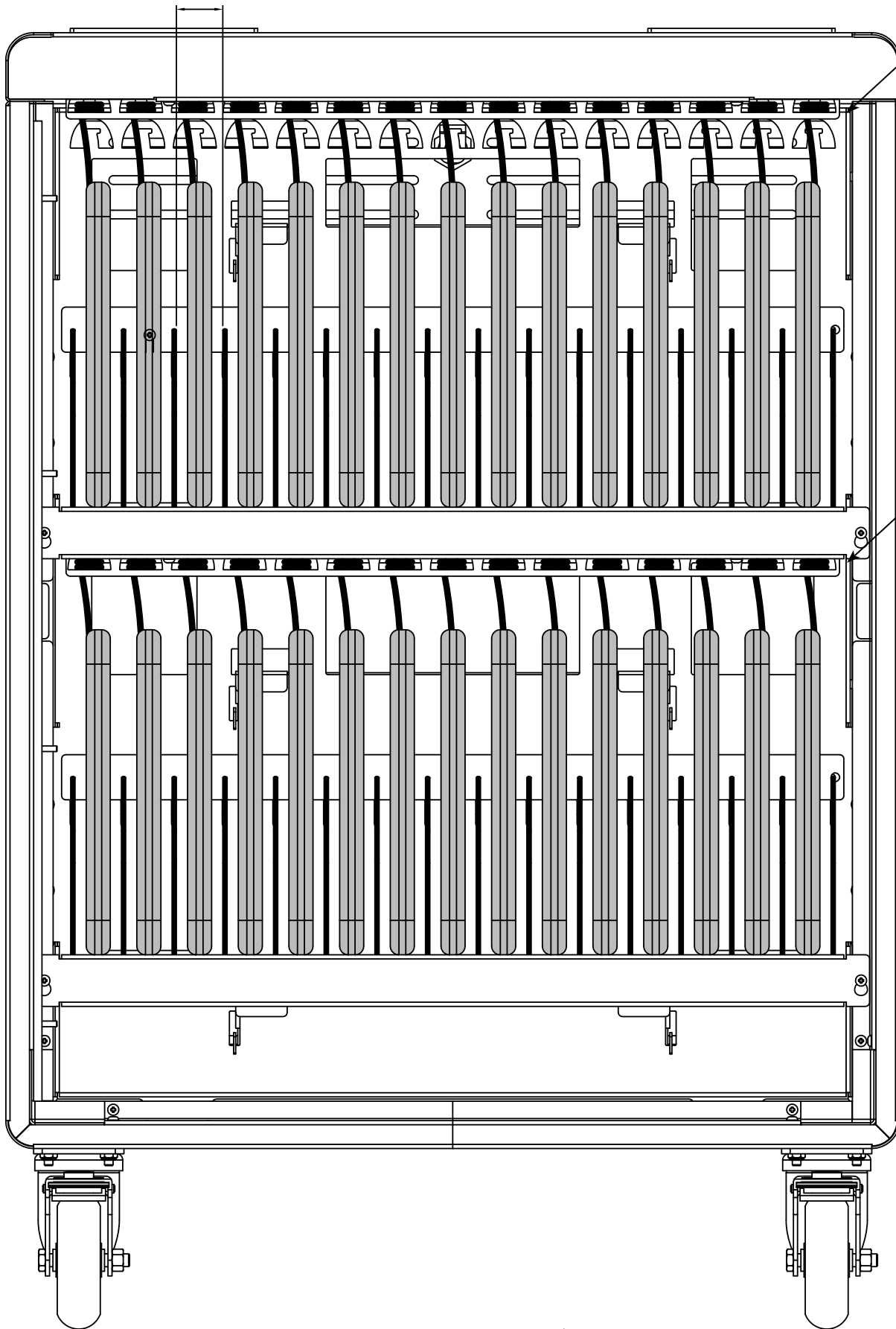

Connect30  
 Power side wiring diagram  
 (shown without locking panel)

15' nominal [1m] 14 AWG,  
 3-wire IEC power cord  
 (to wall outlet)

Power cord to switch  
 or charger

(Shown with power switch)

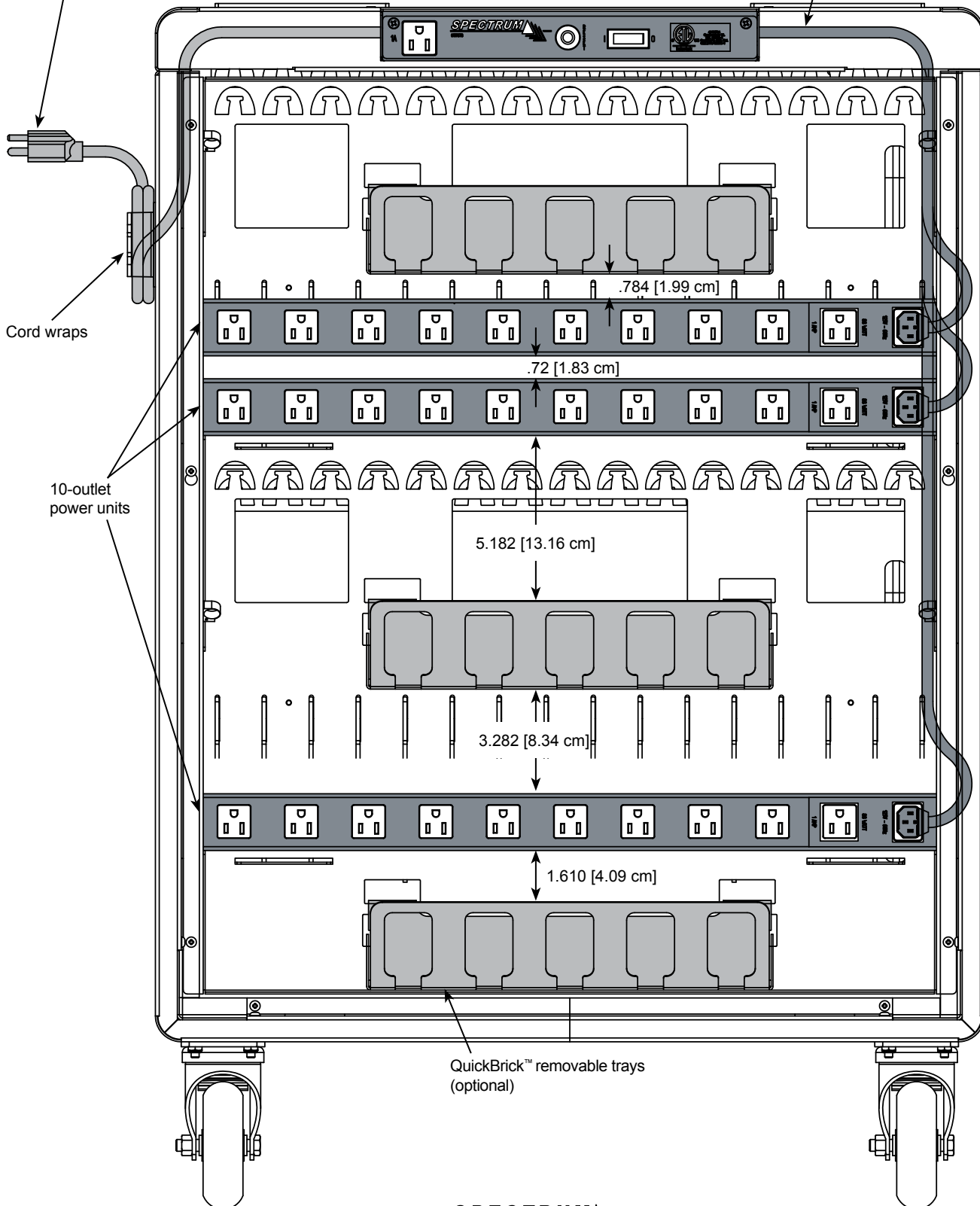

Cord wraps

10-outlet  
 power units

QuickBrick™ removable trays  
 (optional)



Nominal outlet spacing on  
each 10-outlet power unit

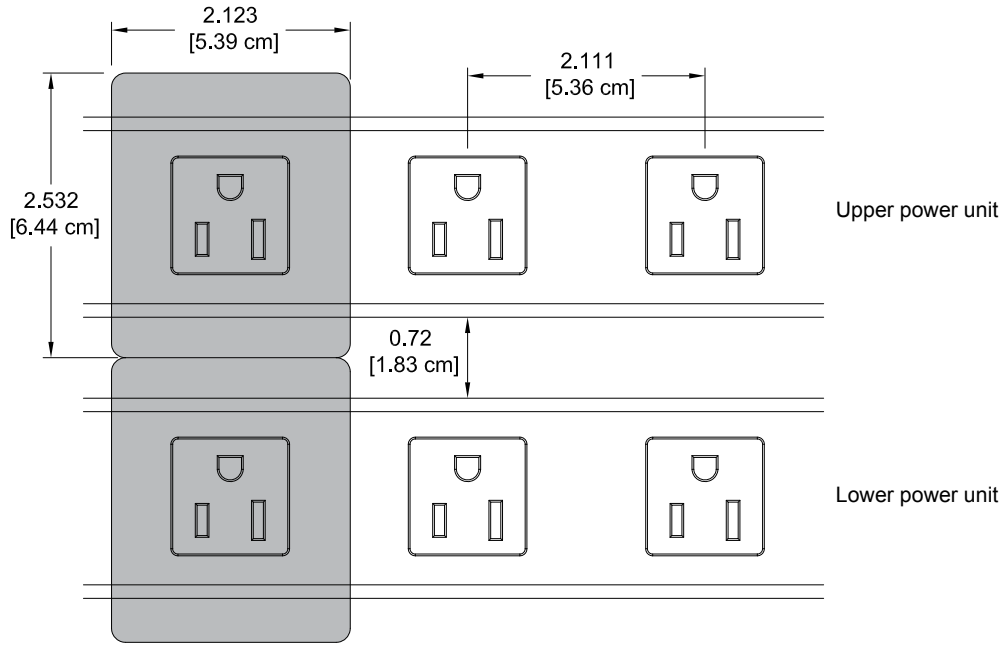

(See p.7 for spacing above and below outlets)

Note: Cart includes three QuickBrick™ removable trays with a Velcro® retaining straps for charge adapters to provide fast and easy wiring for quick deployment.

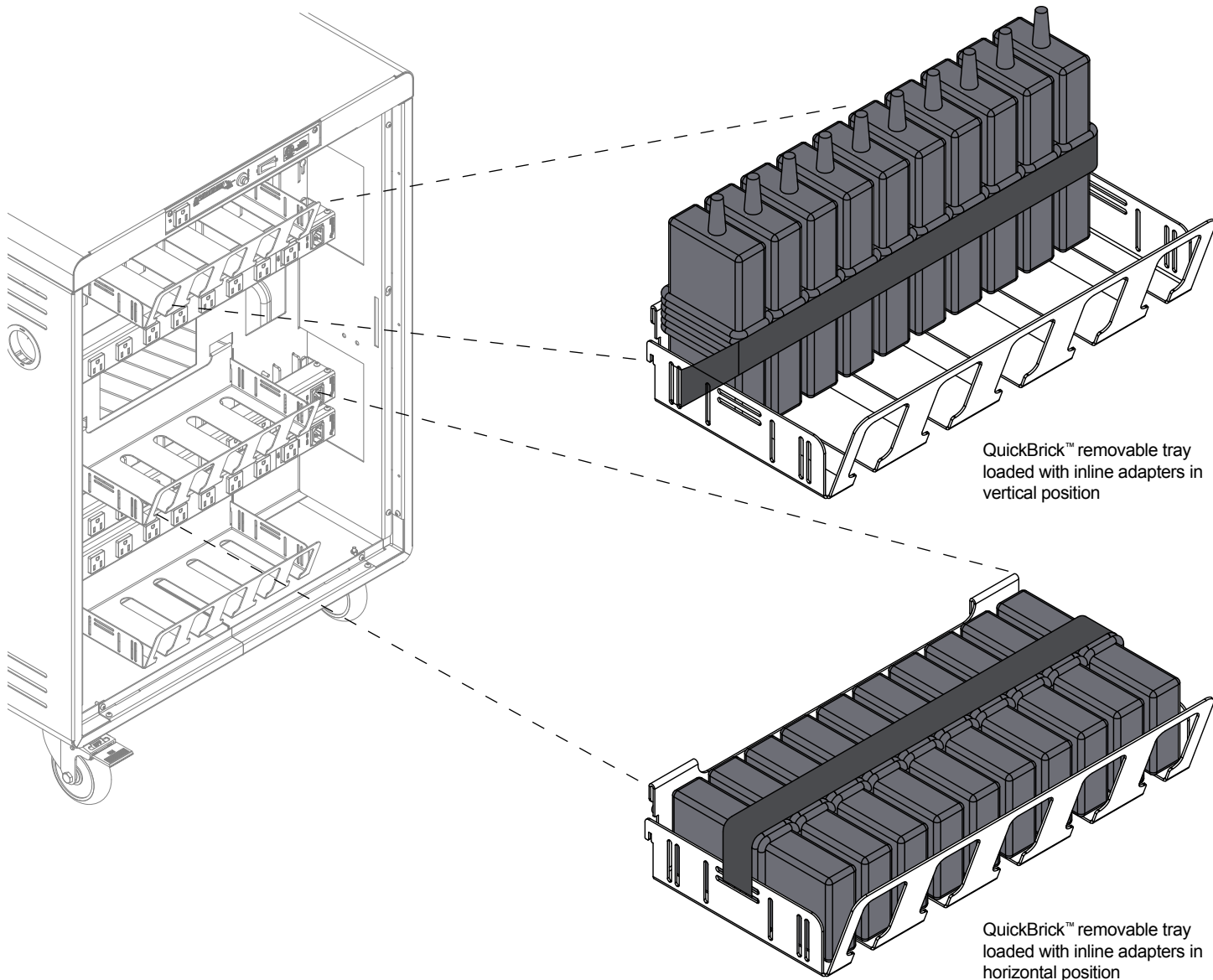

## Accessories



### Velcro® Strap Kit - 95004

(16) .75" [1.91 cm] x 12" [30.48 cm],  
and (32) .75" [1.91 cm] x 5" [12.7 cm]

# PowerProdigy™ System

External side view  
(external access)

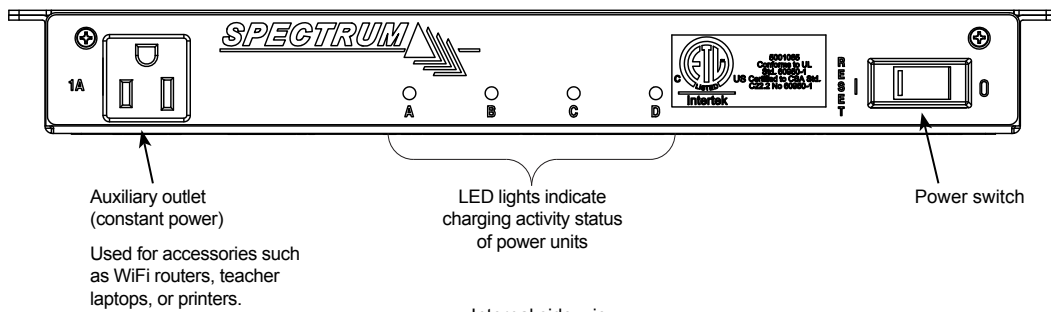

Internal side view  
(internal access)

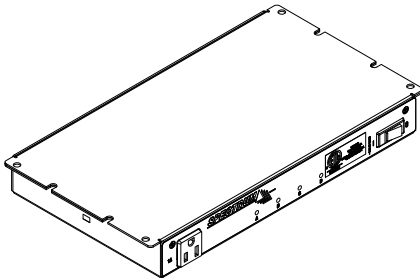
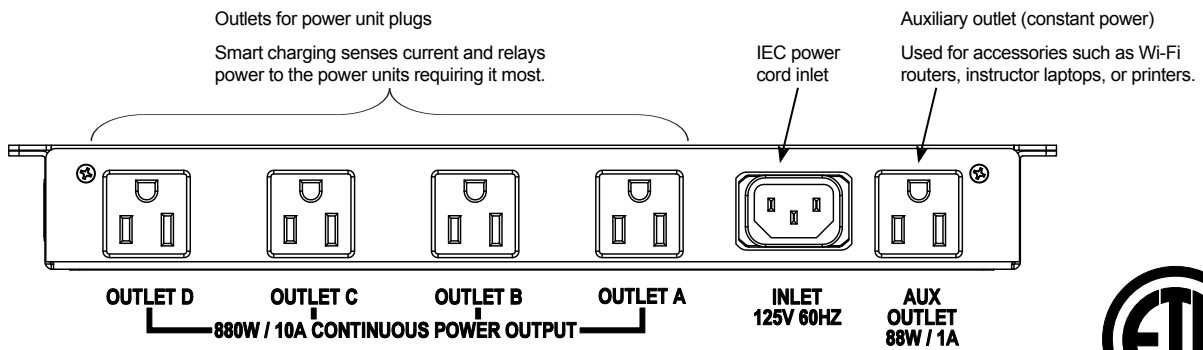

## Specifications:

Input:	125V~/12A, 60Hz
Max output:	125V~/12A, 60Hz
Breaker:	15A, 250 VAC
Cycling Interval:	15 minutes
Cycling outlets:	4 timed internal (A, B, C, D) up to 10A
Auxiliary outlets:	1 external, 1 internal, 1A each (controlled by main on/off switch)
Power cord:	IEC quick-release (replaceable) 15' nominal, 14 AWG, 3-wire
Power switch:	15A, rocker, red-lighted
Indicator lights:	4 Green LED
Enclosure material:	16 gauge steel
Mounting type:	Screw / stud
Dimensions:	12.75"W [324mm] x 7.29"D [185.2mm] x 1.5"H [38.1mm]
Regulatory listing:	ETL recognized (certified to 60950-1)

## Features:

- The PowerProdigy™ charger senses current from up to four, 10-outlet power units and distributes power (up to 10A) to the least-charged devices first. This sensing / switching occurs every 15 minutes. If no devices are plugged into a power unit, the charger skips that power unit and goes onto the next one.
- No adjustments by the user are needed
- If overall amp draw is low enough (below 10A), the charger will send power to all available power units
- Four LED lights indicate charging activity status of each power unit. Lights remaining on continuously indicate power is being provided to all four banks.
- Prevents electrical overload in older classrooms
- Diagnostic-capable mode
- 1A auxiliary outlets (one internal, one external) remain on while the unit is powered on, and can be used (even during charging cycles) to power accessories like a teacher laptop or Wi-Fi access point
- External power switch

## ⚠ CAUTION ⚠

- **Auxiliary outlets are for peripheral use only.** Do not use auxiliary outlets to charge multiple laptops or devices. (Use cycling outlets A, B, C, D for charging.)
- Switch the timer power switch OFF before unplugging or plugging-in the main power unit cords
- Total equipment load not to exceed 12-amps per power unit.
- Do not plug the power cord into an extension cord.
- Inspect power cord before each use. Do not use power cord that is damaged.
- Do not unplug by pulling on the cord.
- Do not step on, drive over, drag, or place objects on the power cord.
- For indoor use only. Do not install or store the unit where it will be exposed to moisture. Keep dry.
- For added safety, plug the timer into a grounded three-prong receptacle controlled by a GFI (Ground Fault Interrupter) circuit breaker.

## Warranty

### WE WILL MAKE IT RIGHT FOR YOU!

Spectrum is committed to provide complete customer satisfaction. Each of our products is manufactured from the best materials available and each product is stringently monitored throughout the production process through our P.A.C.E. program (Product Assurance to meet Customer Expectations).

We expressly warrant that Spectrum products will be of good quality and workmanship and free from defect for the period set out in the warranty table below from the date of delivery. This warranty shall not apply to defects or damage resulting from misuse, abuse, neglect, improper care, modification or repair not authorized by Spectrum, or any other cause outside the control of Spectrum. Spectrum will, at its sole option, either repair or replace the defective product.

This warranty is exclusive; no other warranty, written or oral, is expressed or implied. This warranty is given by Spectrum to Buyer and to no other person or legal entity. No Spectrum dealer, distributor, agent or employee is authorized to make any modification or addition to this warranty.

**NOTWITHSTANDING ANYTHING TO THE CONTRARY, SPECTRUM WILL NOT UNDER ANY CIRCUMSTANCES BE LIABLE FOR INDIRECT OR LIQUIDATED DAMAGES, INCLUDING CONSEQUENTIAL, INCIDENTAL AND SPECIAL DAMAGES. IN NO EVENT SHALL SPECTRUM'S LIABILITY, WHETHER UNDER CONTRACT OR WARRANTY, IN TORT OR OTHERWISE, EXCEED THE PURCHASE PRICE RECEIVED BY SPECTRUM FOR THE PRODUCT AT ISSUE AND "RECALL ACTION" EXPENSES. SPECTRUM SHALL NOT BE SUBJECT TO ANY OTHER OBLIGATIONS OR LIABILITIES, WHETHER ARISING OUT OF BREACH OF CONTRACT, WARRANTY, TORT (INCLUDING NEGLIGENCE AND STRICT LIABILITY) OR OTHER THEORIES OF LAW, WITH RESPECT TO PRODUCTS SOLD OR SERVICES RENDERED BY SPECTRUM, OR ANY UNDERTAKINGS, ACTS OR OMISSIONS RELATING THERETO.**

Our Customer Service Department is ready to provide immediate attention to any questions, comments or concerns. They are available to answer your calls Monday through Friday from 7 am to 5 pm CST. In addition your product comments or concerns are welcome via e-mail at: spectrum@spectrumfurniture.com.

Warranty Table

Item	Warranty Period effective 1/1/2015
Adjustable Crank / Electric Desk Legs	• 1 Year
Flat Panel Desk Gas Cylinders	
Chairs <ul style="list-style-type: none"> <li>• Adjustable Height Chair Parts – including frames, gas cylinders, wood and plastic parts, control handles, casters</li> <li>• Adjustable Height Chair Upholstery</li> <li>• In-Stock Upholstery</li> <li>• Graded-In Fabrics and Customer Owned Material</li> </ul>	<ul style="list-style-type: none"> <li>• 7 Years</li> <li>• 2 Years</li> <li>• 2 Years</li> <li>• No Warranty</li> </ul>
Height Adjustable Columns and Lifts	• 1 Year
General Use Casters	
Electrical (including timers and LINAK actuators)	• 2 Years
Keyboard / Mouse Trays	• 1 Year
Flat Panel Monitor Arms <ul style="list-style-type: none"> <li>• Flat Panel Monitor Arm – General Parts</li> <li>• Flat Panel Monitor Arm – Gas Cylinders</li> </ul>	<ul style="list-style-type: none"> <li>• 5 Years</li> <li>• 2 Years</li> </ul>
Desks and Lecterns <ul style="list-style-type: none"> <li>• Computer Desk Chassis</li> <li>• Cart Chassis</li> <li>• Lectern Chassis</li> </ul>	• 10 Years

