





Assembly Instructions:

To purchase parts or accessories, please contact us at
www.spectrumfurniture.com
 1-800-235-1262
 Thank you for choosing Spectrum products!

 (4) 052605
 1/4-20 x 15mm JC Bolt

 (1) 025039
 4mm Hex Wrench

 (2) 025068
 5/16-18 x 1-5/8" Glide

 (1) 025069
 Glide Wrench

Before you begin, please make sure all parts and proper quantities are included. Any parts damaged during shipment must be reported within 15 days of receipt. To report information regarding damages or if you have any questions, please call 1-800-235-1262.

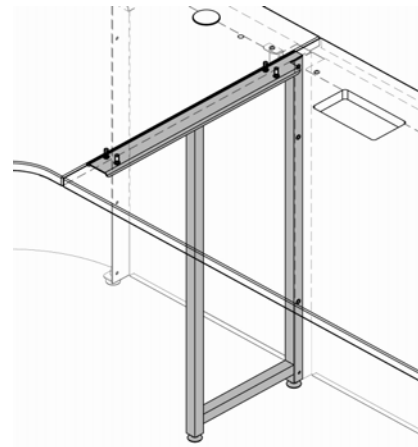

Mid-Support Leg for IMC

#68104 - 29"H

#68154 - 36"H

Mid-Support Leg Assembly

Tools Required:
 4mm Hex Wrench (included)
 Glide Wrench (included)

- Install the (2) glides onto the bottom of the leg. The glides can be adjusted later to level the console.
 - Align the mid-support leg and wall filler panel mounting holes as shown. **Figure 1.**
 - Attach the mid-support leg to the wall filler panels with (4) 1/4-20 x 15mm JC bolts.
- Note:** These bolts come with the wall filler panels
- Set both work surfaces onto console with the seam centered over the mid-support leg.
 - Attach to work surfaces with (4) 1/4-20 x 15mm JC bolts.

Note: Mid-support legs are used at the joint connection of two work surfaces to provide support for two or more open spaces (wall filler panels) wide.

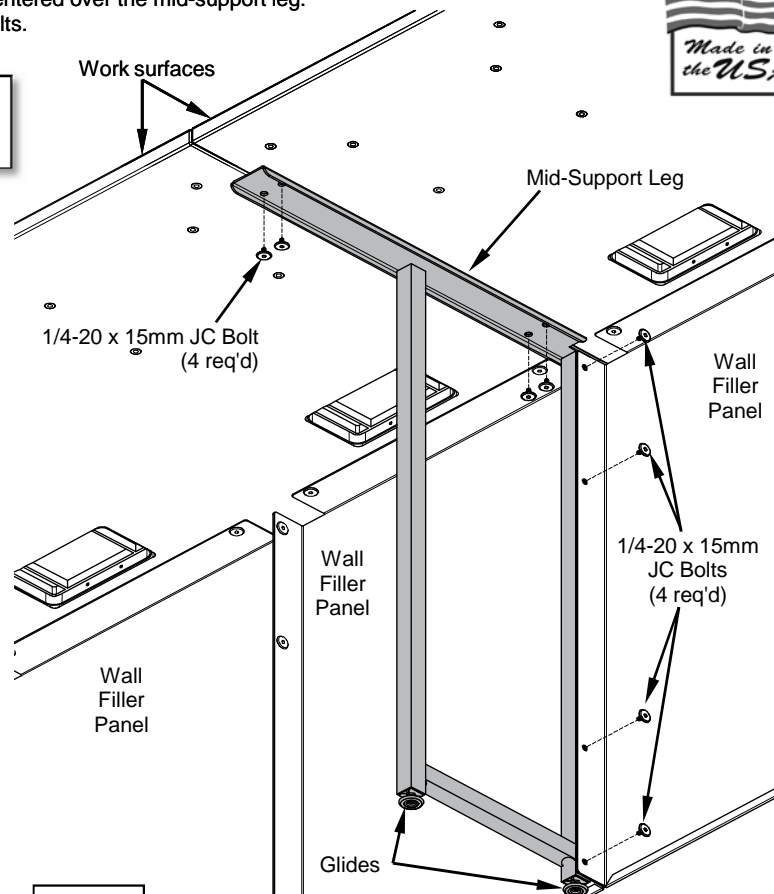

Figure 1



SPECTRUM
 INDUSTRIES INC.

Touchboards

205 Westwood Ave, Long Branch, NJ 07740
 Phone: 866-94 BOARDS (26273) / (732)-222-1511
 Fax: (732)-222-7088 | E-mail: sales@touchboards.com