

# Instructions:

To purchase parts or accessories, please contact us at  
[www.spectrumfurniture.com](http://www.spectrumfurniture.com)  
1-800-235-1262  
Thank you for choosing Spectrum products!



(4) 052605  
1/4-20 x 15mm JC Bolt



(1) 025039  
4mm Hex Wrench

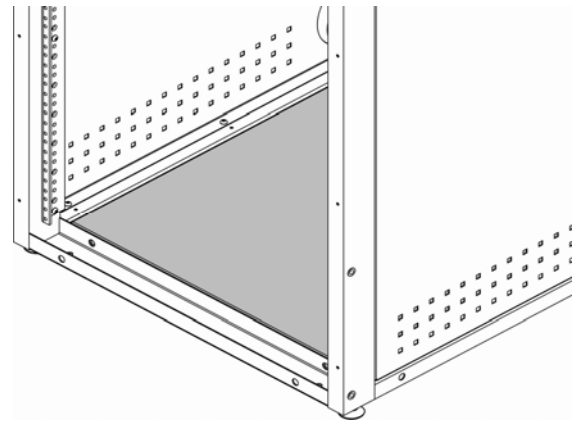

## Equipment Rack Bottom Shelf for Instructor Media Console #68203

Before you begin, please make sure all parts and proper quantities are included. Any parts damaged during shipment must be reported within 15 days of receipt. To report information regarding damages or if you have any questions, please call 1-800-235-1262.

Tools Required:  
4mm Hex Wrench (included)

### 1. Shelf Installation

- Align the shelf with the (2) front mounting holes at the bottom of the equipment rack as shown. **Figure 1.**
- Attach with (2) 1/4-20 x 15mm JC bolts.
- Open the rear door and repeat this procedure on the rear of the equipment rack-installing (2) additional 1/4-20 x 15mm JC bolts.
- Tighten all bolts securely.

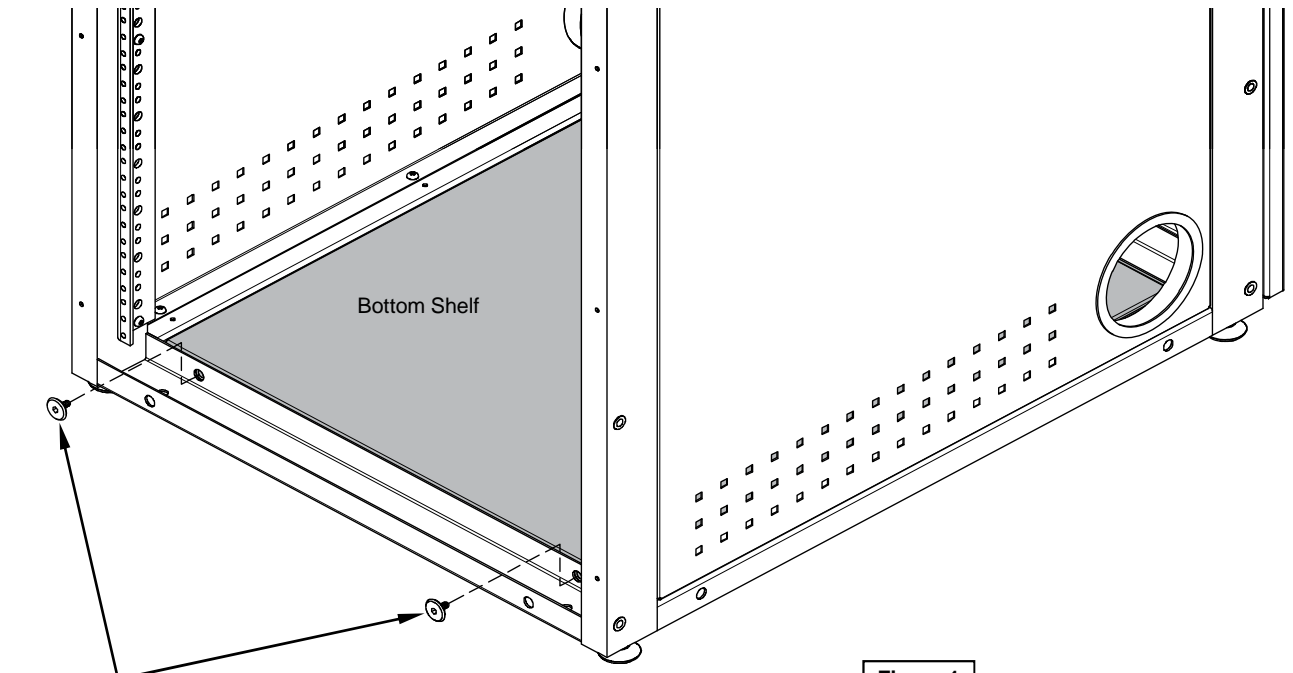

Figure 1

1/4-20 x 15mm JC Bolt  
(2 on front, 2 on rear)



**SPECTRUM**  
INDUSTRIES INC.

# Touchboards

205 Westwood Ave, Long Branch, NJ 07740  
Phone: 866-94 BOARDS (26273) / (732)-222-1511  
Fax: (732)-222-7088 | E-mail: [sales@touchboards.com](mailto:sales@touchboards.com)