



Mastercool[®]
"World Class Quality"

Instruction Manual DEEP VACUUM PUMP



DO NOT ATTEMPT TO OPERATE WITHOUT USING OIL!!!

In order to make the best use of your investment, familiarize yourself with the new features and operating instructions before starting pump. Routine care and maintenance of your vacuum pump will give you years of reliable service.

Retain shipping box and packing material for use if factory warranty service is required.

IMPORTANT!: Use oil specifically refined for Deep Vacuum Pumps. Use of oil not refined for Deep Vacuum Pumps and/or operating with contaminated oil will void warranty.

Each vacuum pump has been factory tested for CFM and micron performance. The serial number has been recorded. Complete and mail the warranty form immediately to validate your warranty!



WARNING



Wear Safety Goggles

OPERATING INSTRUCTIONS

1. OIL FILL

This vacuum pump has been tested at the factory and shipped with only trace amounts of oil. **OIL MUST BE ADDED BEFORE OPERATING!** Failure to add oil will damage cartridge and void warranty!

- Make sure the oil drain valve located below the front casing is closed before attempting to add oil. (See ref. #4 in parts breakdown.)
- Remove the large brass oil fill plug from the top of pump and insert the oil bottle into the fill port. (See ref. #5 in parts breakdown.)
- Slowly add oil until oil level rises to the top of the Oil Level Line. Do not overfill with oil!
- Replace the oil fill plug.

**CAPACITY: 2 CFM = 24 oz., 5 CFM = 18 oz.,
7.5 CFM = 24 oz., 10 CFM = 24 oz.**

2. CHECKING OIL LEVEL

- Open the gas ballast valve (small brass fitting located next to the handle) one turn. Do not remove!
- Start pump and run with intake port capped for about two minutes. Observe the oil level with the pump running. The oil level in the sight glass should be even with the level line.

c. If the level is low, open the intake port and run pump for 15 seconds, stop pump and observe oil level again. Add a small amount of oil as needed.

3. GAS BALLAST VALVE

The gas ballast valve must be 1/4 turn to fully opened for the first part of the evacuation procedure. After about two minutes close the valve and continue the evacuation procedure to reach ultimate vacuum. **FAILURE TO OPEN THE GAS BALLAST VALVE MAY RESULT IN DAMAGE TO YOUR CARTRIDGE.** Failure to close the valve during evacuation will result in poor vacuum performance.

During the first stages of evacuation, vapors are highly concentrated. Unfortunately, some vapors will condense into a liquid and mix with the oil, thus reducing the oil's ability to produce a deep vacuum. The **GAS BALLAST VALVE** emits a controlled amount of dry air into the pump during compression to minimize this effect and keep oil relatively clean during the first part of the evacuation. Periodically remove the Gas Ballast Valve Needle and clean or replace the O-ring. Clean mating surfaces and lightly coat with vacuum pump oil before securely retightening.

4. CHANGING OIL

In order to reach the deep vacuum required, your vacuum pump needs clean, moisture-free oil during evacuation. Dirty oil becomes a mixture of corrosive acids and water that effects the pump's ability to pull a deep vacuum. Left sitting in the pump, this sludge will rust and erode internal surfaces...shortening the pump's life.

Care should be taken to avoid contact of oil with skin or eyes. OIL MAY BE HOT! Used oil should be properly disposed of in a leakproof corrosive-resistant container according to local regulations.

- a. After every evacuation, while the pump is warm and oil is thin, take a small sample of oil from the drain port.
- b. If the oil is contaminated, drain the oil by placing the pump on a level surface and opening the oil drain valve. Catch the waste oil in a container and properly dispose of it.
- c. If the pump has been sitting for more than one month, the oil is considered contaminated regardless of appearance and should be changed as outlined above.
- d. To add oil, close drain, remove the oil fill cap and fill to the Oil Level Line with fresh oil.

5. INTAKE CONNECTIONS

Replace all caps and finger-tighten. Do not use caps with damaged or missing O-rings and always store vacuum pump with capped ports to prevent dirt and moisture contamination.

6. PUMP MOTOR

The PUMP and OIL must be above 30°F. The line voltage must be equal to the rating on the motor nameplate + / - 10%. Normal operating temperature is approximately 160°F, which is HOT to the touch! Line voltage and ambient temperature will affect the normal operating temperature somewhat. Your vacuum pump is designed for continuous duty and will run for extended periods without overheating. The motor has an automatic resetting overload protection feature. If the motor will not restart the pump after shut-off, it may have opened the thermal protection. Disconnect the pump from the system, wait about 15 minutes for the motor to cool down and then try again.

RETURNING A PUMP

Please fax a request for a return authorization number to 973-252-2455. This applies to both warranty and non-warranty service!

Pumps returned for service without a return authorization number will not be accepted.

In your fax, include your NAME, ADDRESS and PHONE NUMBER along with a detailed explanation of the problem. We will contact you (i.e. your phone number) to discuss your problem and determine if you have to return your pump, or if we can trouble shoot it over the phone.

If you have to return your pump, we will issue you an RMA#. Then, please follow the instructions below.

- Drain oil, cap all ports and place tape over the exhaust port located on the end of the pump handle. If you fail to do this, your pump will not be accepted and it will be returned!!!
- Use the original shipping box and inserts if available. Shipping damages are impossible to claim on used machinery.

PARTS LIST

(TO SPECIFY 220V MOTORS, ADD -220 TO PART#)

REF#	DESCRIPTION	PART#	REF#	DESCRIPTION	PART#
1.	PUMP COVER 2 & 5 CFM	90062-12	9.	INTAKE TEE (SINGLE STAGE)	90052-31
	PUMP COVER 7.5 CFM	90067-12	10.	FLOAT BALL	90052-20
2.	SIGHT GLASS ASSEMBLY	90052-14	11.	GAS BALLAST FITTING W/O-RING	90052-29
3.	COVER CAP SCREW (1 pc.)	90052-33	12.	RUBBER FOOT W/BOLT	90052-38
4.	DRAIN VALVE	90052-28	13.	SHAFT SEAL	90052-06
5.	OIL FILL PLUG W/O-RING	90052-30	14.	SMALLER O-RING ON HOUSING	90052-23
6.	CARTRIDGE KIT 2 CFM	90152	15.	PUMP COVER O-RING	90052-13-R
	CARTRIDGE KIT 5 CFM	90156	16.	PUMP HANDLE W/GRIP	90052-40
	CARTRIDGE KIT 7.5 CFM	90157	17.	SHAFT COUPLER ASSEMBLY	90052-02-R
7.	PUMP HOUSING	90062-11	18.	MOTOR-115V (2 & 5 CFM PUMPS)	90052-01-R1
8.	HAND VALVE ASSEMBLY (2 STAGE)	90056-01		MOTOR-115V (7.5 CFM PUMP)	90057-01-R1

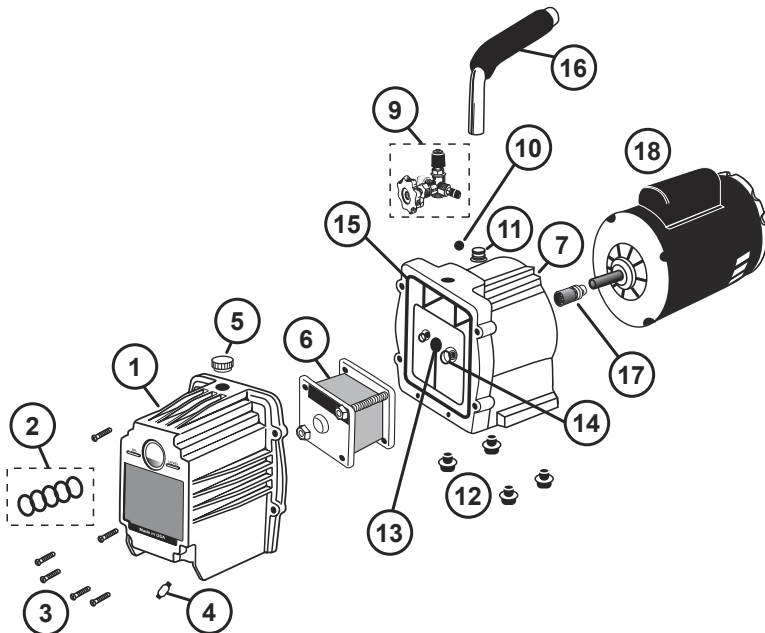

LIMITED WARRANTY INFORMATION

Mastercool Inc. warrants their Vacuum Pumps against defects in material and workmanship for a period of one year. This warranty does not cover failure due to abuse, improper usage, or progressive wear and tear. Warranty becomes valid to the original owner and is effective on the purchase date.

WARRANTY SERVICE IS PROVIDED THROUGH THE FACTORY ONLY.

Please contact the service department toll free for parts, service concerns, or to obtain a return authorization number for warranty repair.

TOLL FREE Warranty Service 1-888-825-6989