

Assembly Instructions

Important

Before you begin, please make sure all parts and proper quantities are included. Any parts damaged during shipment must be reported within 15 days of receipt. To report information regarding damage, to purchase parts or accessories, or if you have any questions, please contact us at:

www.spectrumfurniture.com
715-723-6750, 800-235-1262

Thank you for purchasing Spectrum products!

Note: Before proceeding with this installation, the display stand should be fully-assembled on the table. The shroud works with one 37"-63" monitor.

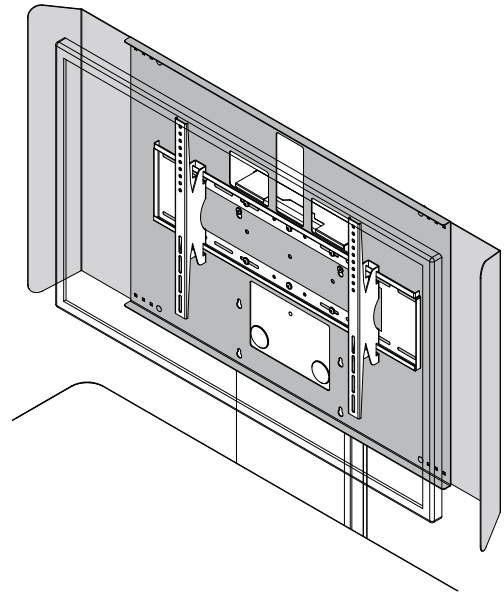

Display Shroud for InVision Display Stand 95532

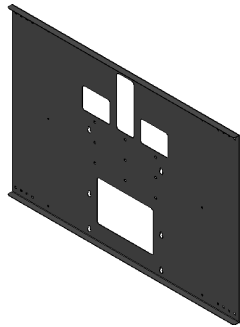

(1) 0116552
shroud base plate



(2) 0116551
shroud

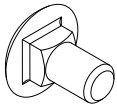

(4) 0106417
1/4-20 x 1/2"
carriage bolt



(10) 026059
1/4" washer



(10) 034195
1/4-20 wing nut

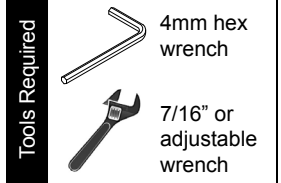

1. Remove monitor mount

If the monitor mount is installed, it will need to be removed from the display stand before installing the shroud.

- To remove the monitor mount, first remove the (4) 1/4-20 x 15mm JC bolts and back panel. **Figure 1A.**



205 Westwood Ave, Long Branch, NJ 07740
Phone: 866-94 BOARDS (26273) / (732)-222-1511
Fax: (732)-222-7088 | E-mail: sales@touchboards.com

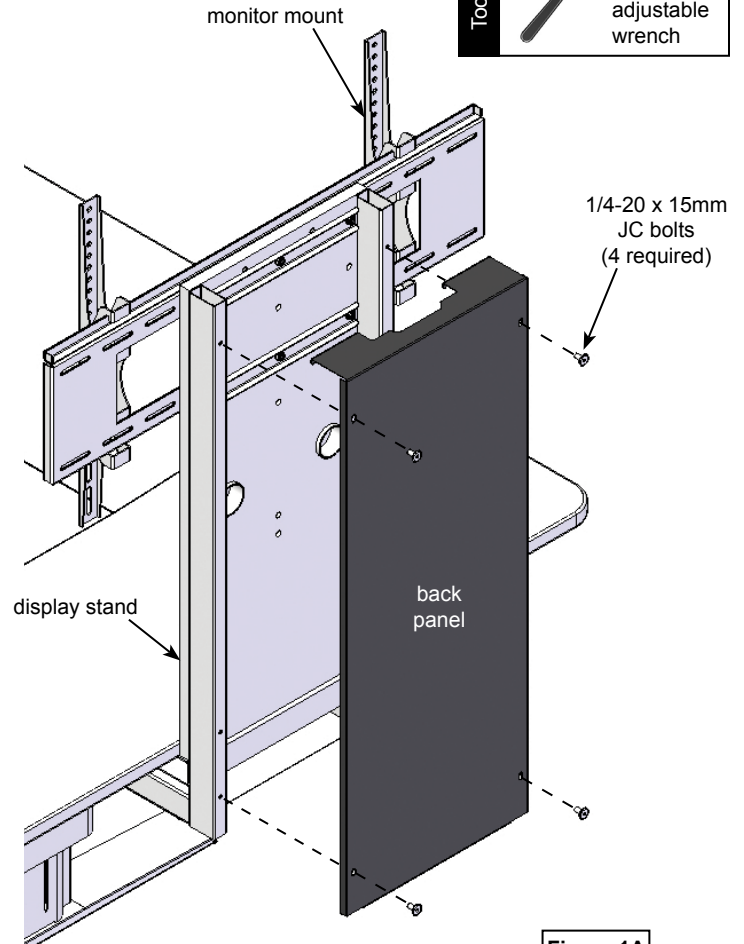

Figure 1A

2. Remove the (6) 1/4-20 x 30mm JC bolts, and 1/4-20 locknuts and set the mount aside. Retain all fasteners. **Figure 1B.**

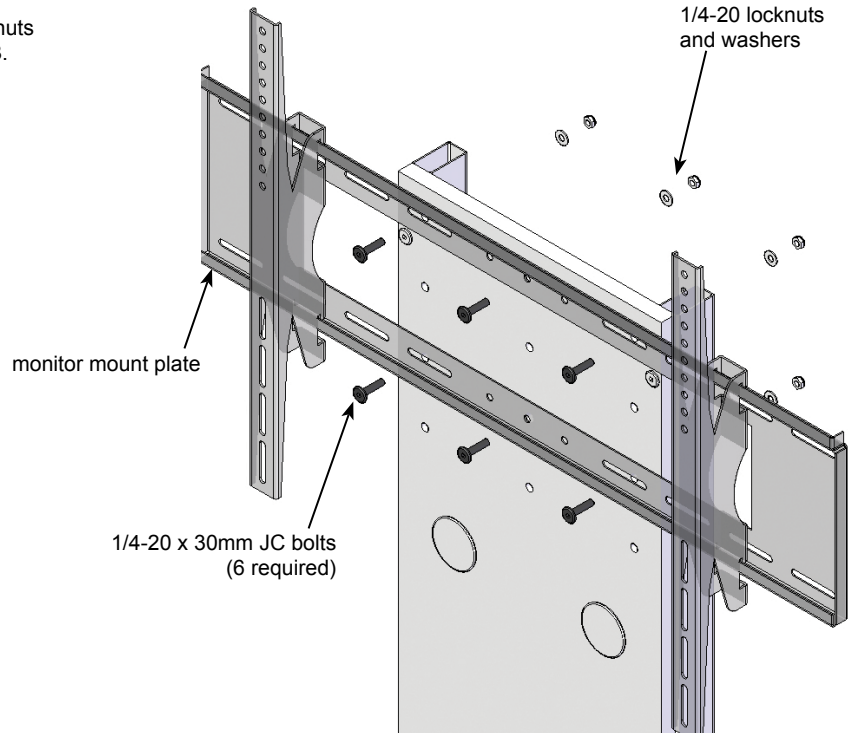

Figure 1B

2. Install shroud base plate

1. Two sets of mounting holes are available for the shroud / monitor mount. Choose a set of holes based on your monitor size and preferred height. **Figure 2A.** Typical installations use the upper holes for better viewing and clearance.

Two-vertical positions available

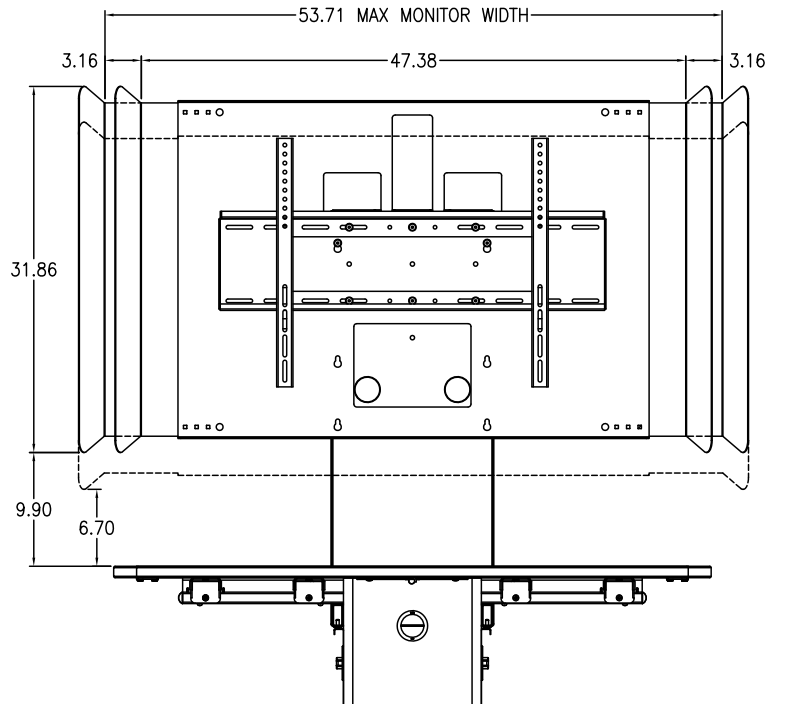

Figure 2A

2. Loosen the (4) 1/4-20 x 30mm JC bolts on the display stand laminate panel. **Figure 2B.**
3. Using the (4) keyholes in the shroud base plate, hang the shroud base plate on the loosened JC bolts.
4. Secure the shroud base plate and monitor mount plate to the display stand with (6) 1/4-20 x 30mm JC bolts, 1/4" washers, and 1/4-20 locknuts. Tighten bolts equally and securely.

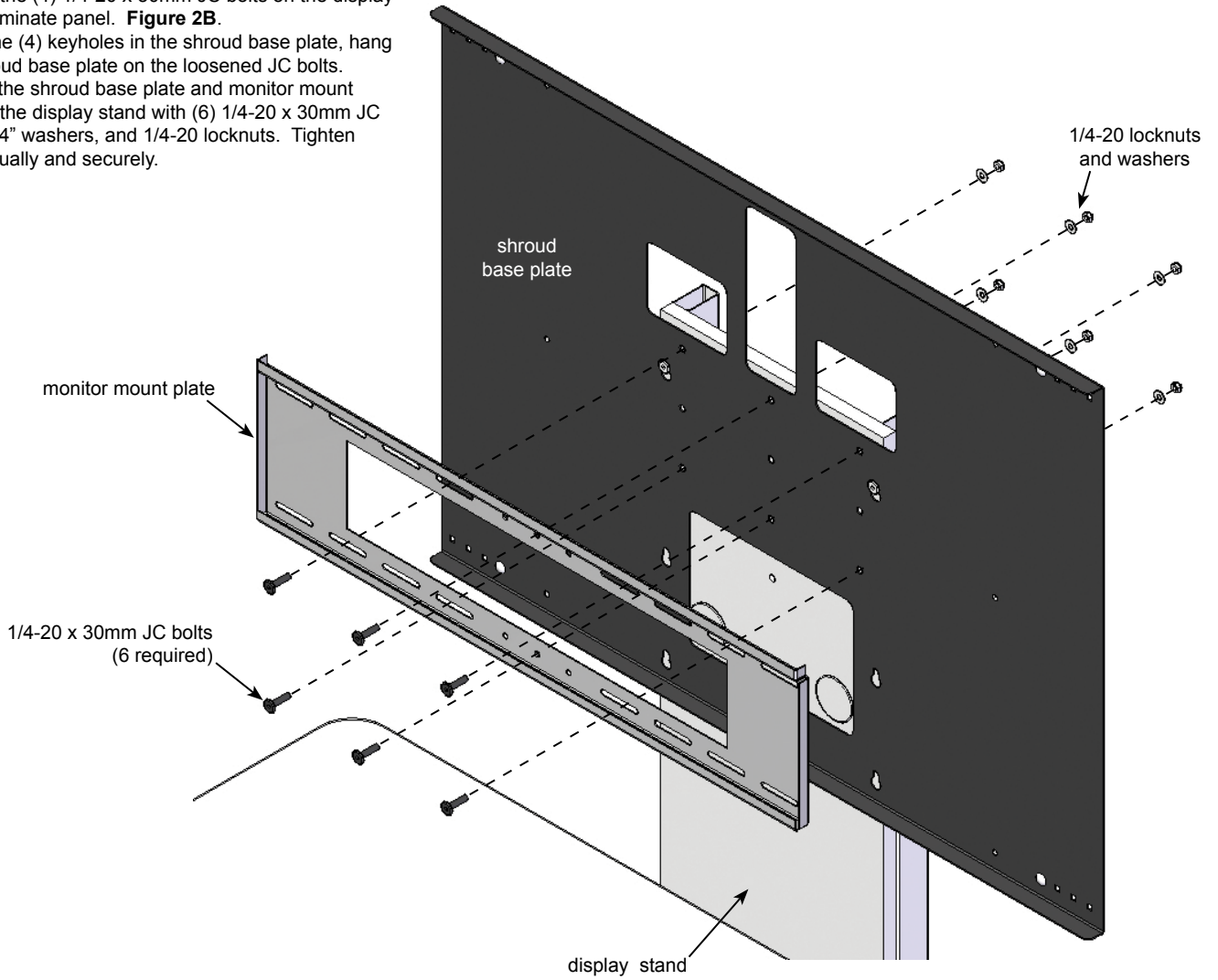

Figure 2B

3. Install monitor

- Install monitor to display stand. **Figure 3.**
- Refer to the instructions included with the monitor mount for complete monitor installation procedure.
- The assembled display stand accommodates most 37"-63" monitors. Do not exceed the available monitor weight capacities. See chart below.

	Added InVision Access option			Weight capacity available for installed monitor
	Display Shroud	Dual Display Mount	Camera Mount	
	95532 -38 lbs	37124 -29 lbs	37108 -7 lbs	
InVision Access Display Stand 37120 (100 lb capacity)	✓			= 62 lbs
	✓		✓	= 55 lbs
	No additional options added			= 100 lbs

**Note: The display shroud is not compatible with the dual display mount.*

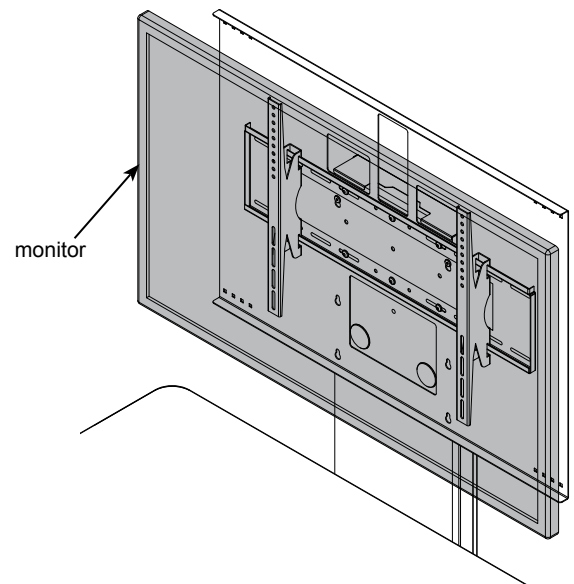

Figure 3

4. Install monitor shrouds

1. Align the mounting holes of each monitor shroud with the shroud base plate. **Figure 4.** Each shroud will attach behind the shroud base plate (display stand-side).
2. Place the shroud slots over the base plate weld studs and move the shroud to the widest position first, then adjust to fit the monitor. Leave 1-2 inches between the edge of the monitor and angled portion of the shroud to maximize sound projection from behind the monitor.
3. Secure each shroud to the base plate with (2) 1/4-20 x 1/2" carriage bolts, (5) 1/4" washers, and (5) 1/4-20 wing nuts. Place the carriage bolts in the closest available mounting holes next to the shroud.
4. Make sure both shrouds are equally spaced from the monitor edges and tighten the wing nuts securely.

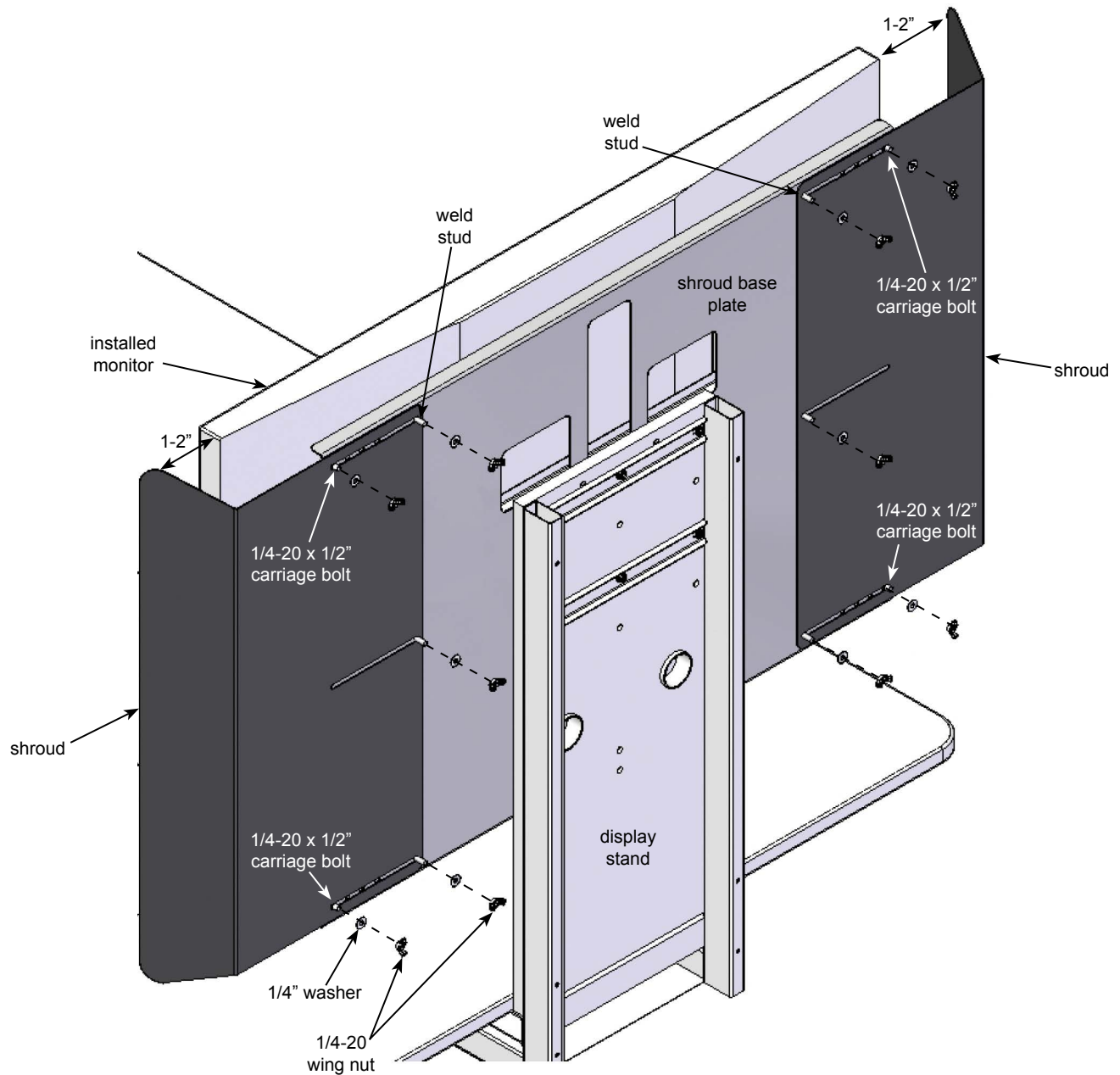

Figure 4

5. Route monitor wiring and install back panel

1. Route cords / wires to the monitor using the wiring tray and grommets. Wire routing options are shown in **Figure 5**.
2. After all wiring has been completed, install the back panel with (4) 1/4-20 x 15mm JC bolts and tighten securely.

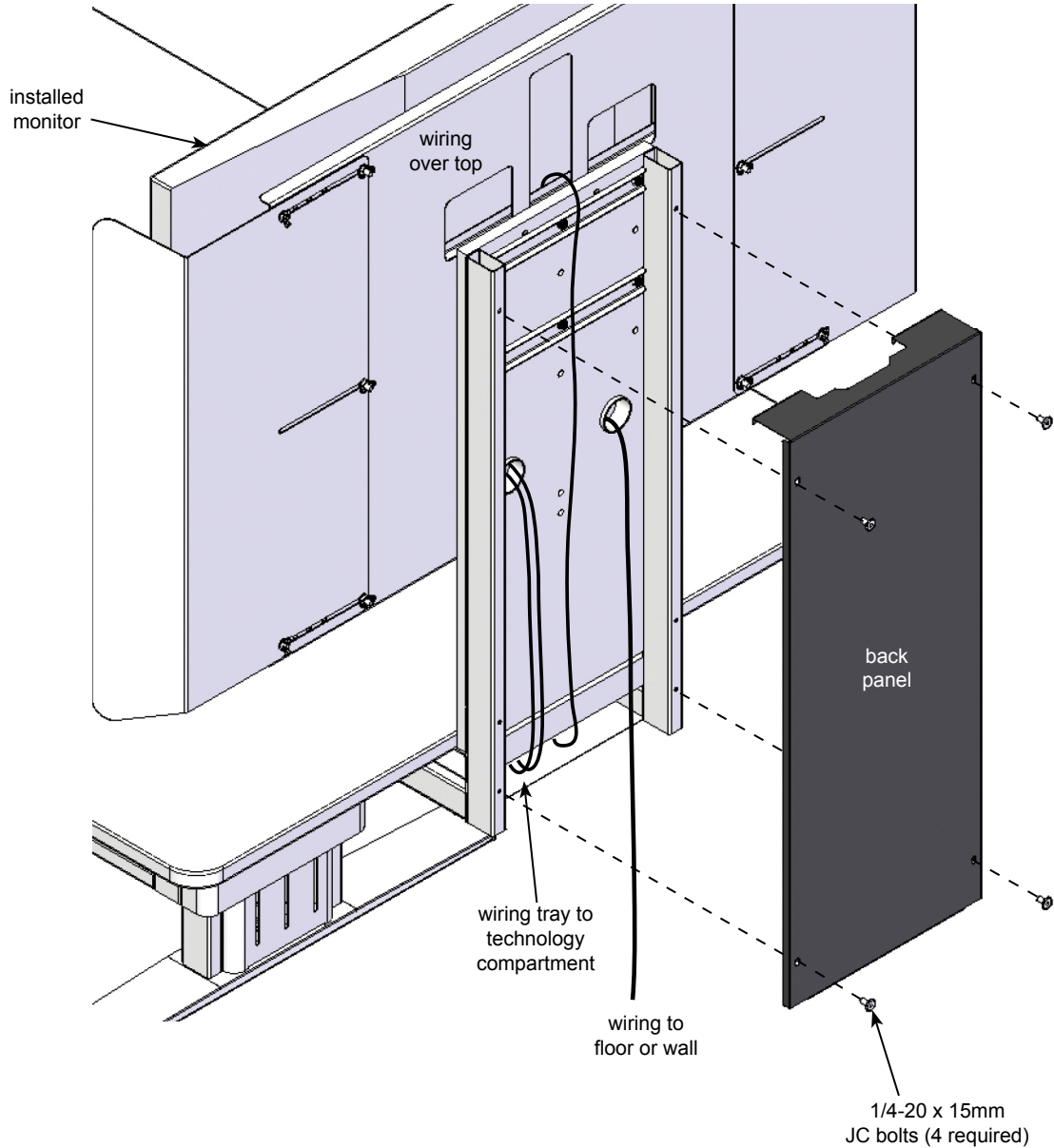

Figure 5

⚠ WARNING ⚠

The monitor should always be lifted off the stand before moving the table.