

MODEL 95533 Installation Instructions

Desk Clamp

- 1
- 2
- 3

Thru-Desk

8111-cup, 8251-cup, 8318-cup | 8111-thru, 8251-thru, 8318-thru

- 1
- 2

Wall Mount

- 1
- 2

*Hardware not included.

Reverse Wall Mount

8111-wall, 8251-wall, 8318-wall

- 1
- 2

*Hardware not included.

Grommet Hole

- 1
- 2
- 3

> 2.5"

Side Bolt

- 1
- 2

*Hardware not included.

MODEL 95533

Parts List

ITEM	DESCRIPTION / PART NO.	QUANTITY
A	Mount Column 401328 <i>Model 7000, 7045, 3500, 3545</i> 8269 <i>Model 7500, iLift™, Arcview™ (9177 Series)</i>	1
B	Base Plate 406656 <i>Model 7000, 7045, 3500, 3545</i> 8321 <i>Model 7500, iLift™, Arcview™ (9177 Series)</i>	1
C	Large "L" Bracket 701117 <i>Model 7000, 7045, 3500, 3545</i> 702828 <i>Model 7500, iLift™, Arcview™ (9177 Series)</i>	1
D	Small "L" Bracket 701116	1
E	Rectangular Spacer 701544	1
F	3/8-16x1" Flat Socket Cap Screw 701124 <i>Model 7000, 7045, 3500, 3545</i> 701855 <i>Model 7500, iLift™, Arcview™ (9177 Series)</i>	1

ITEM	DESCRIPTION / PART NO.	QUANTITY
G	3/8-16 x 7/8" Flat Socket Cap Screw 701799	1
H	3/8-16 Nylon Stop Nut 701418	1
I	3/8-16 x 7/8" Button Socket Cap Screw 701122	1
J	3/8-16 x 2-1/2" Hex Head Bolt 700268	1
K	1/2-13 x 3" Socket Set Screw 701126	1
L	Foam Pad 701120 <i>Included with Model 7000 and 8111-cup only</i>	1



MODEL 95533

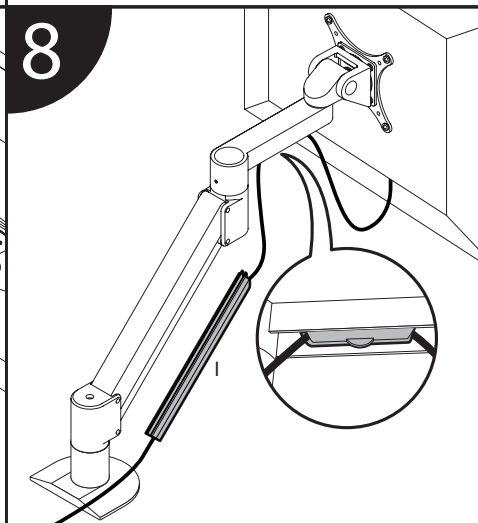
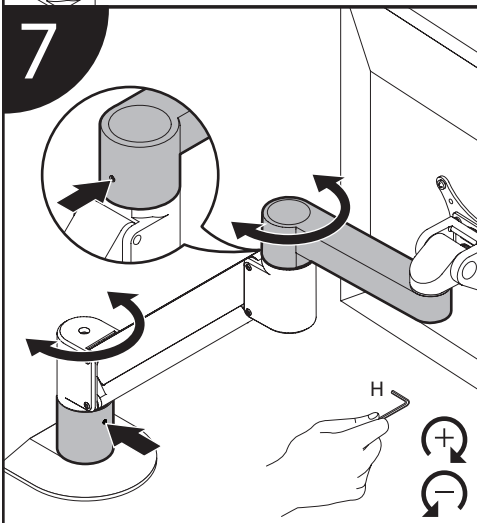
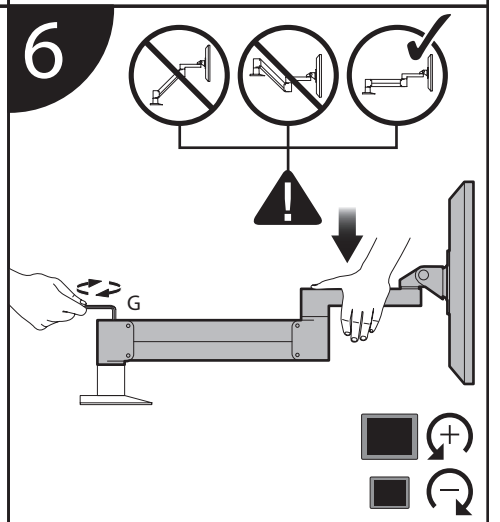
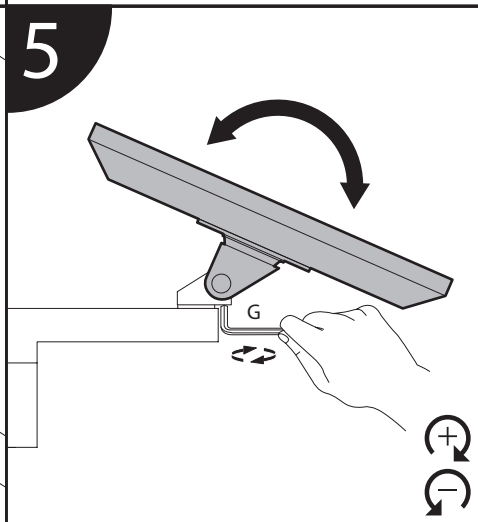
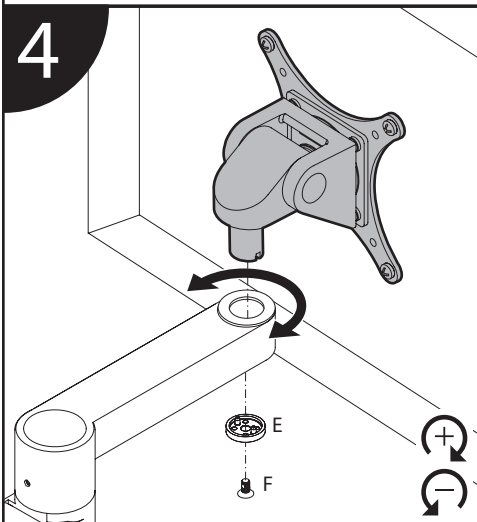
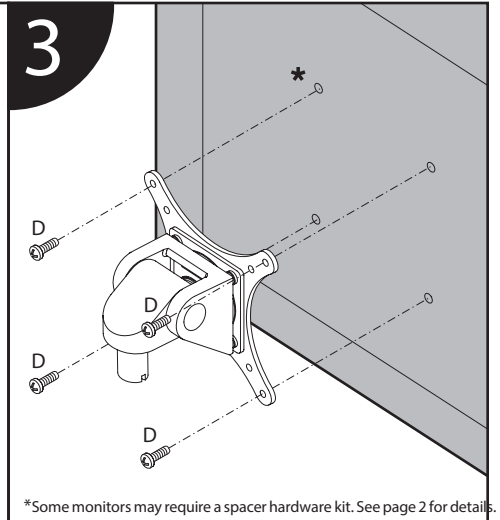
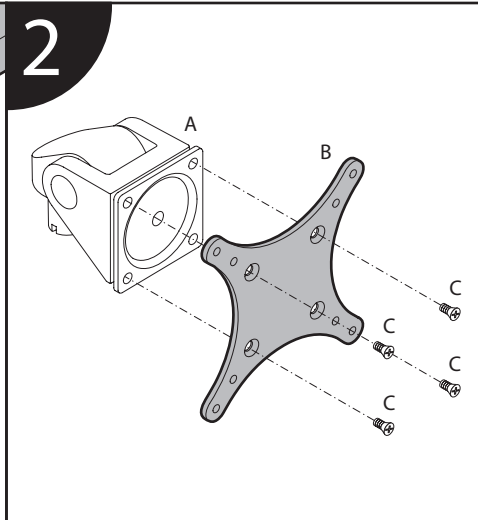
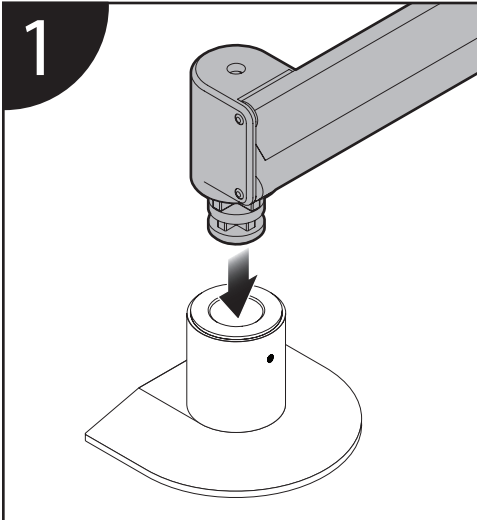
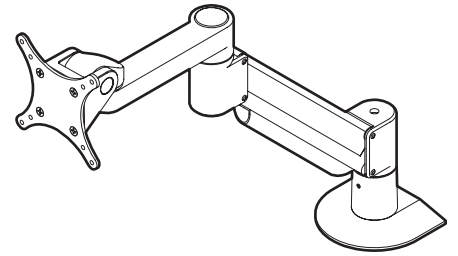

Installation Instructions

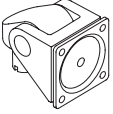
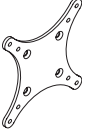

MODEL 95533

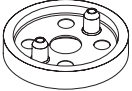
Parts List

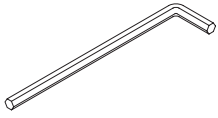
ITEM	DESCRIPTION / PART NO.	QUANTITY
A	 Monitor Tilter 40 5397	1
B	 75 /100mm VESA [®] Adapter Plate 105 587	1
C	 10 -32 x 3/8" Phillips Pan Head Screw 70 2281	1 (4-pack)
D	 M4 x 12mm Phillips Pan Head Screw 702 096	1 (4-pack)
E	 Dog Washer 105189	1

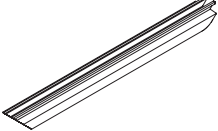
ITEM	DESCRIPTION / PART NO.	QUANTITY
F	 10 -32 x 3/8" FPhMS w/Lock Patch 70 5198	1
G	 7/ 32" Allen Wrench 70 1127	1
H	 3/ 32" Allen Wrench 70 0146	1
I	 Ca ble Cap 10 2043-9.5	1

How do I counterbalance my arm?

1

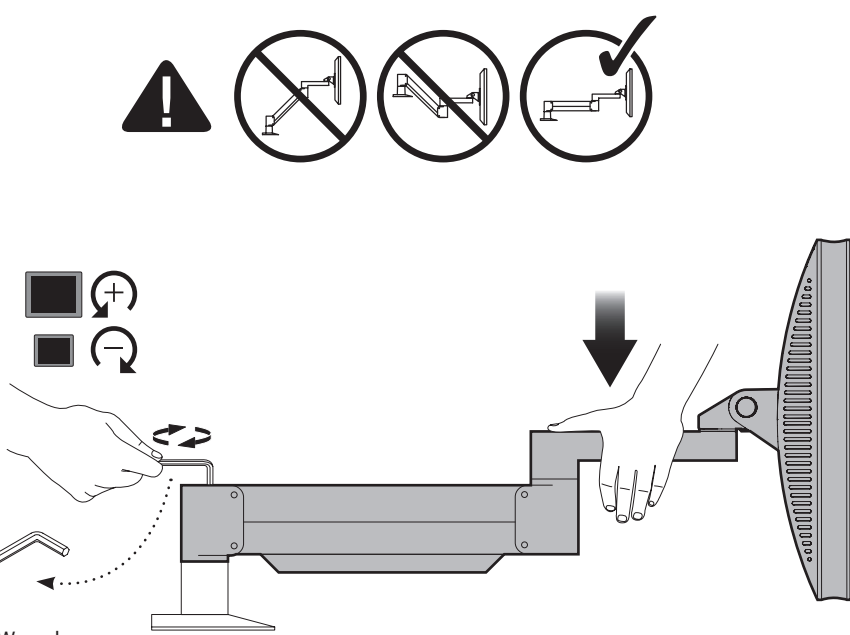

IMPORTANT!

- Monitor must be on arm
- Arm must be in mount

Press the arm down to approximately parallel with the desk prior to turning the strength adjustment screw.

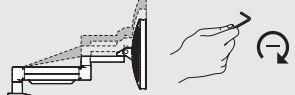

If the arm drifts upward, turn the adjustment screw clockwise.

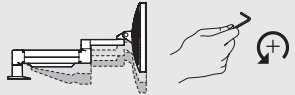

If the arm drifts downward, turn the adjustment screw counter-clockwise.

Depending on the weight of your monitor you may have to make 15-20 turns.

7/32" Allen Wrench

2

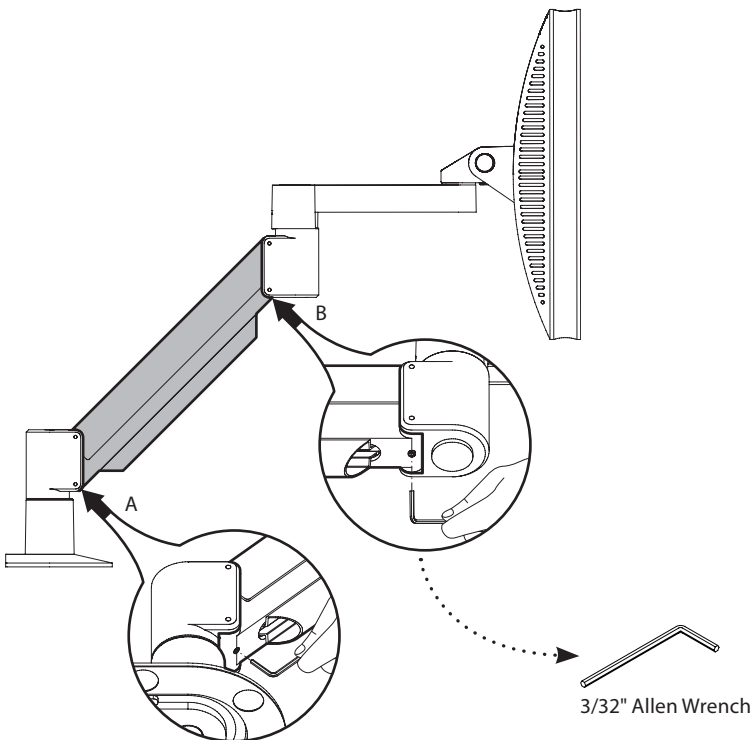

In some instances, further counterbalance adjustments are needed to allow the arm's instant height adjustment function to work properly.

If your arm is not staying in position after performing step 1, follow these steps:



With arm in raised position, tighten set screw (A).

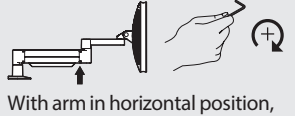

With arm in horizontal position, tighten set screw (B).

Do not over tighten screws.

3/32" Allen Wrench

95533

Installation Instructions | Horizontal Positioning

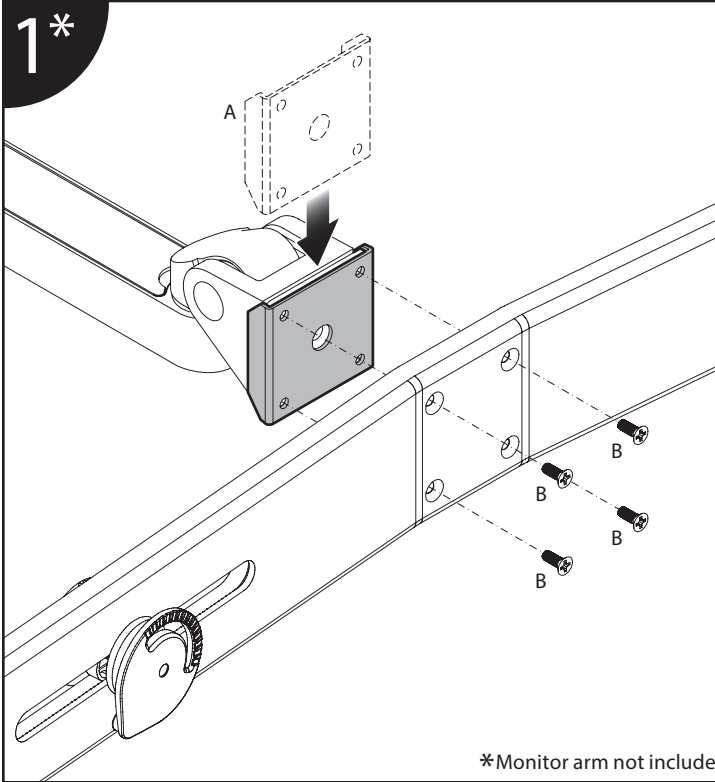
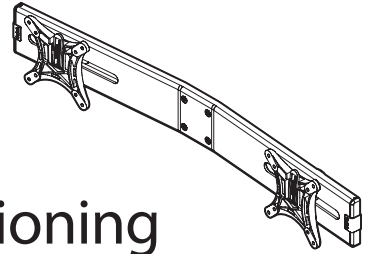

*Monitor arm not included.

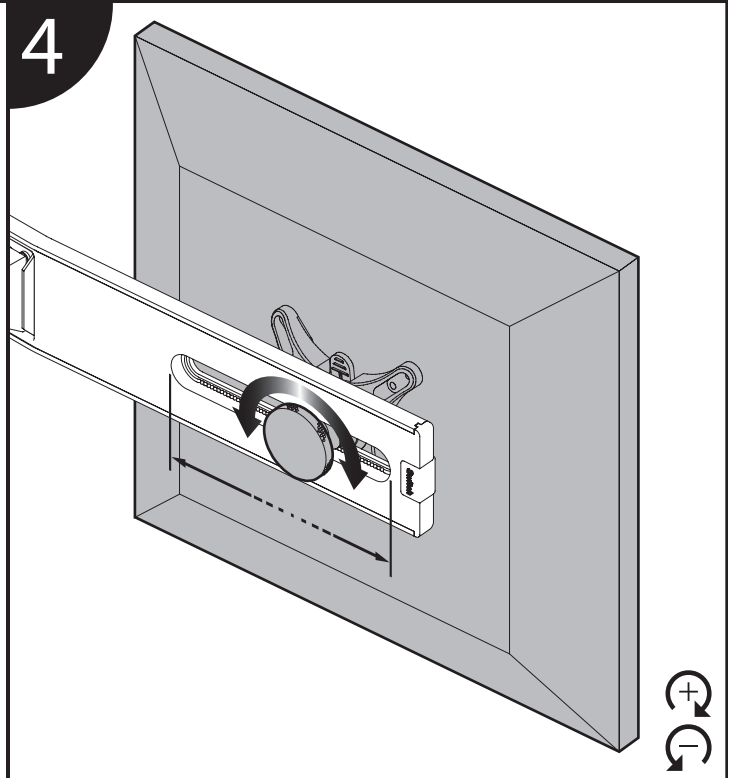
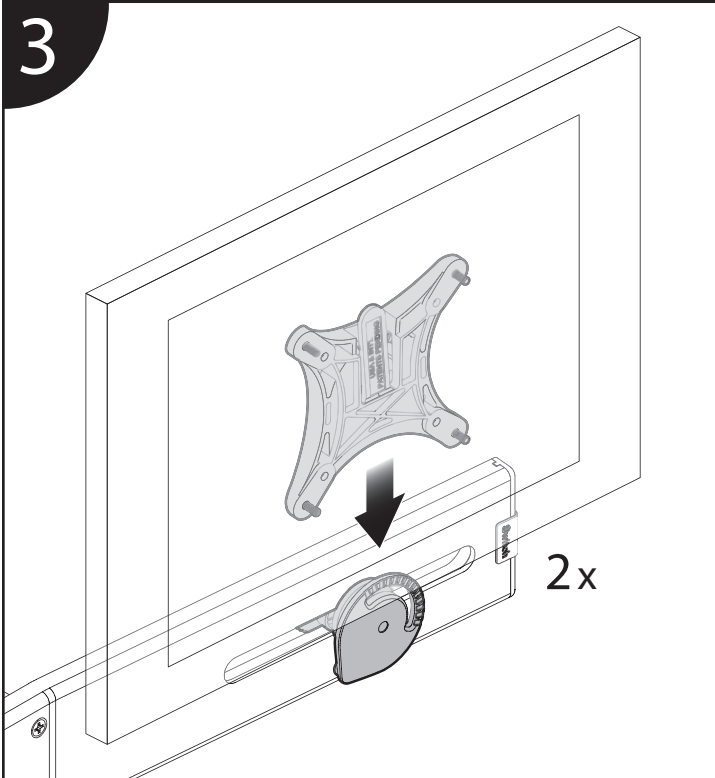
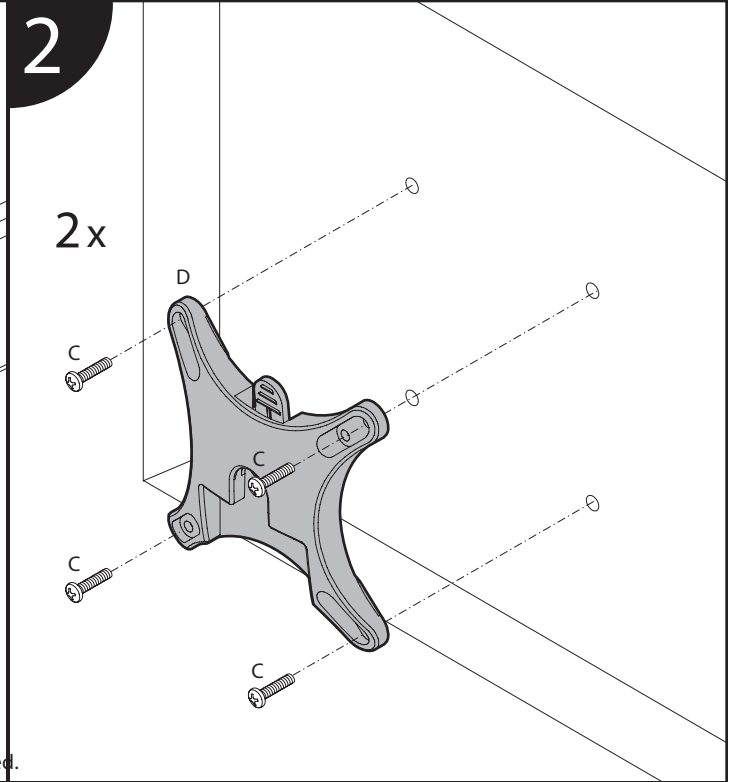

95533

Installation Instructions | Vertical Positioning

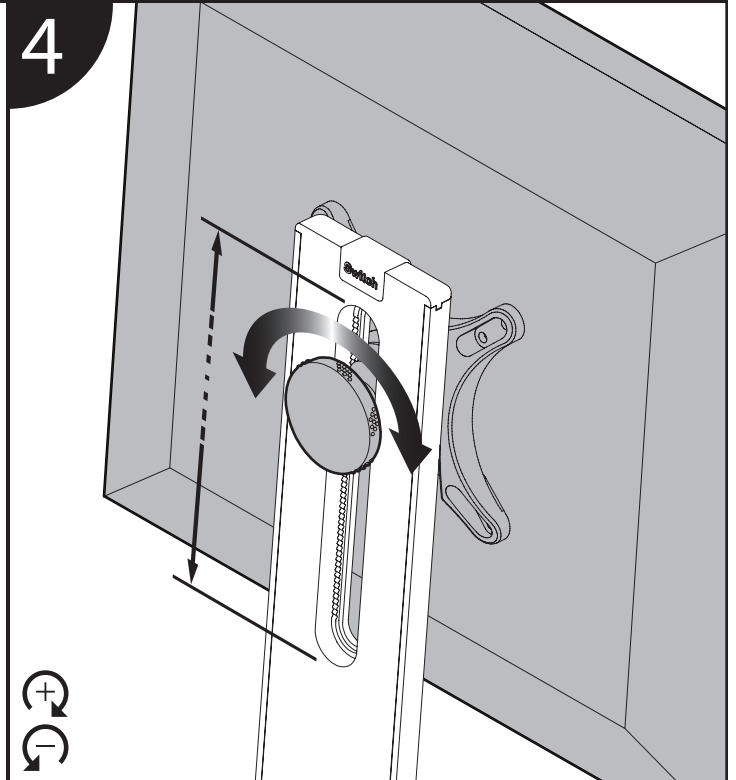
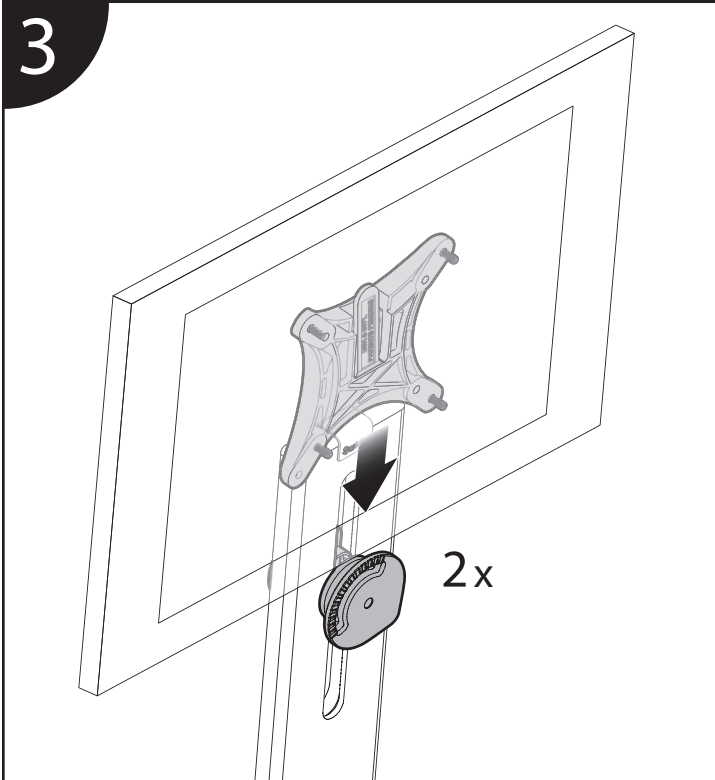
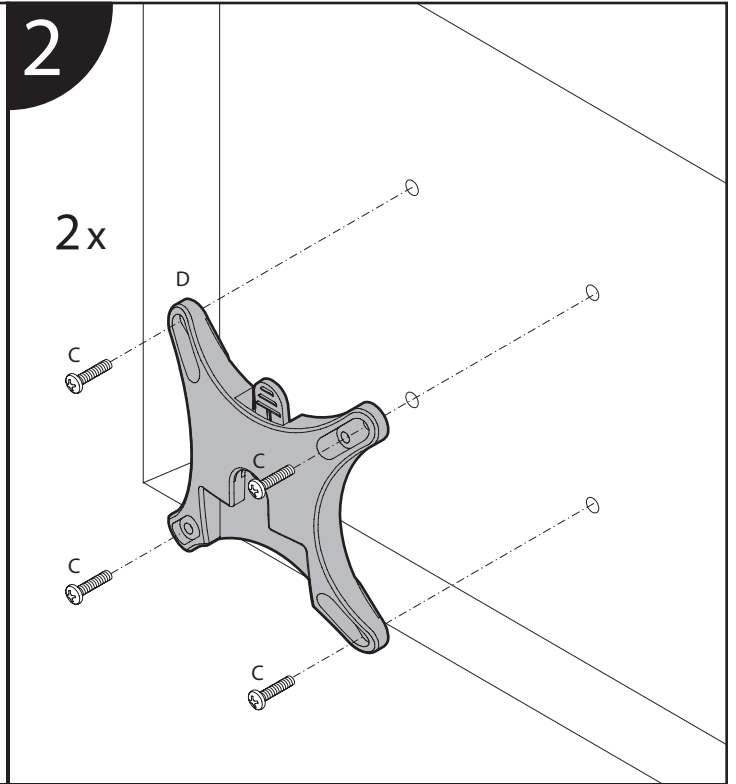
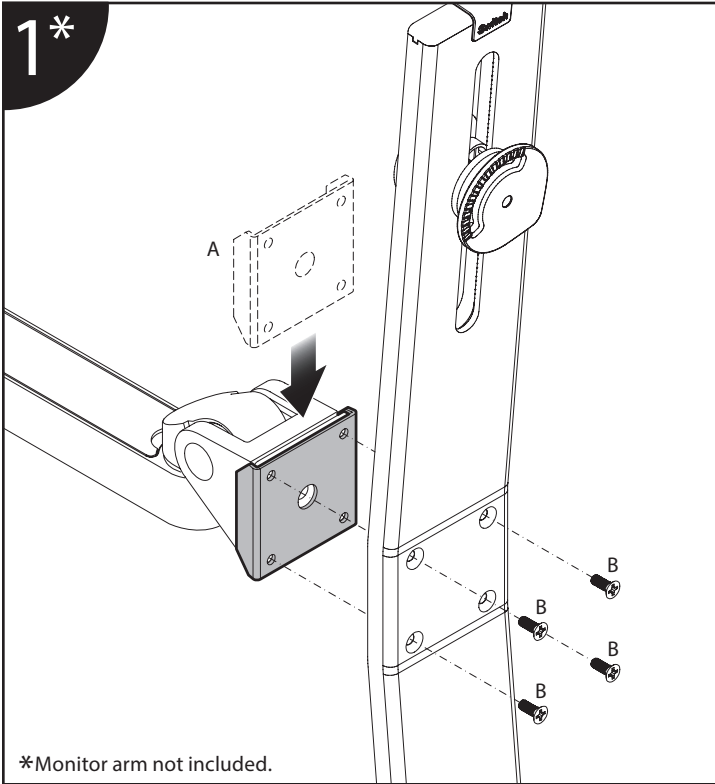

95513 Parts List

ITEM	DESCRIPTION	PART / NO.	QUANTITY
 <p>A</p>	Rotation Prevention Bracket	106271	1
 <p>B</p>	10-32 1/2" x FPHMS	709129	4
 <p>C</p>	M4 x 12mm Pan Head Screw	701153	8
 <p>D</p>	75/100mm VESA® Adapter	109464	2