

Assembly Instructions

To purchase parts or accessories, please contact us at
www.spectrumfurniture.com
1-800-235-1262
 Thank you for purchasing Spectrum products!

Before you begin, please make sure all parts and proper quantities are included. Any parts damaged during shipment must be reported within 15 days of receipt. To report information regarding damages or if you have any questions, please call 1-800-235-1262.

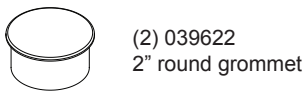

(2) 039622
2" round grommet

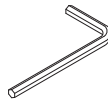

(1) 025039
4mm Hex Wrench

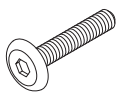

(2) 0102063
1/4-20 x 35mm JC bolt

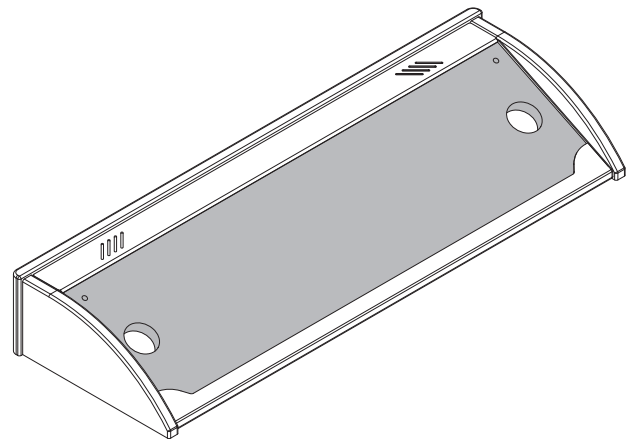

Blank Overbridge Panel

#96501 - small
 #96504 - medium
 #96507 - large

1. Layout cutout(s)

- Before any cuts are made, determine the size of the cutout(s) needed on the overbridge panel.
- The panel dimensions and recommended maximum cutout sizes are shown in **Figure 1**. Determine which panel you have (small, medium, or large) and the preferred location on the panel for your controller (left, centered, or right).

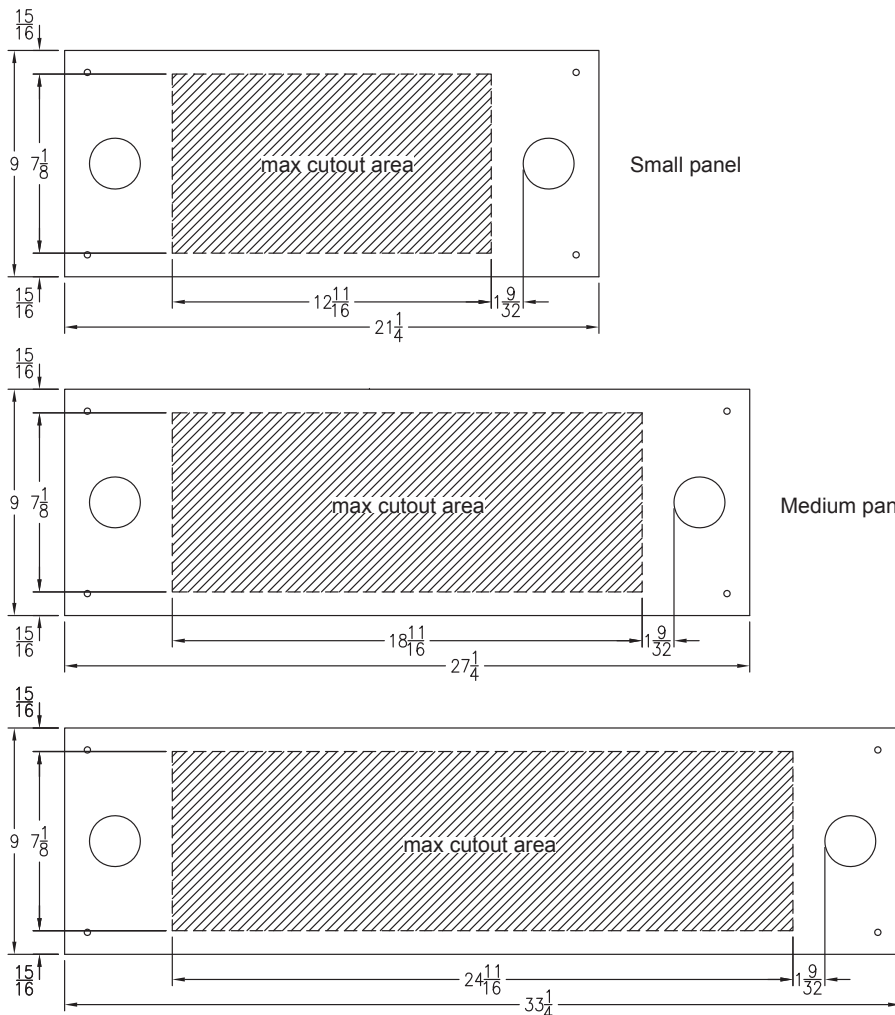

Tools Required

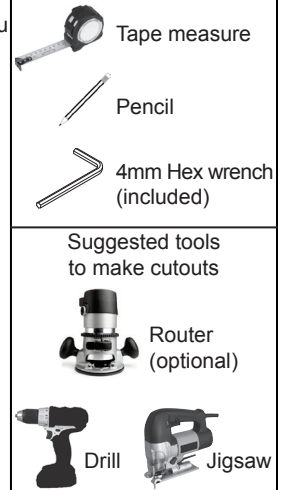

Note: The overbridge panel is symmetrical. Rotating the panel 180° and re-attaching to the overbridge will place the cutout on the opposite side of the overbridge if necessary.

Figure 1

- C. Determine the depth of your controller and verify it will not collide with the worksurface or any other objects under the overbridge when the panel is attached. **Figure 2.**
- D. When the cutout location(s) have been verified, mark each cutout on the panel with a pencil.

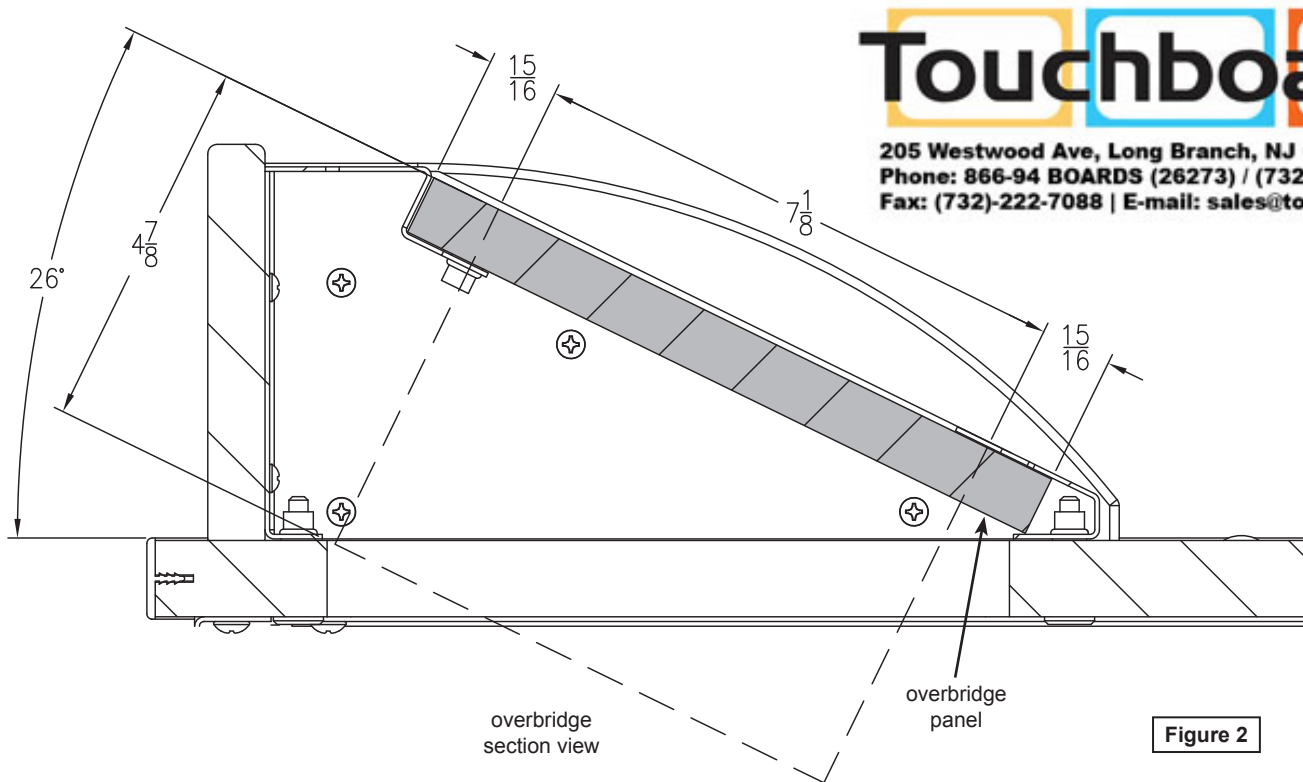

Touchboards
 205 Westwood Ave, Long Branch, NJ 07740
 Phone: 866-94 BOARDS (26273) / (732)-222-1511
 Fax: (732)-222-7088 | E-mail: sales@touchboards.com

Figure 2

2. Make panel cutouts

- A. Make the cutout(s) in the panel with a jigsaw or router.
 Note: Masking tape can be used on the laminate-side at the cut lines to minimize chip-out.

3. Attach panel to overbridge frame

- A. Set the panel into the overbridge frame opening. Note: It may be easier in some cases to install the controller in the panel before attaching the panel to the overbridge.
- B. Secure with (2) 1/4-20 x 35mm JC bolts and tighten securely.
- C. Install (2) 2" grommets.

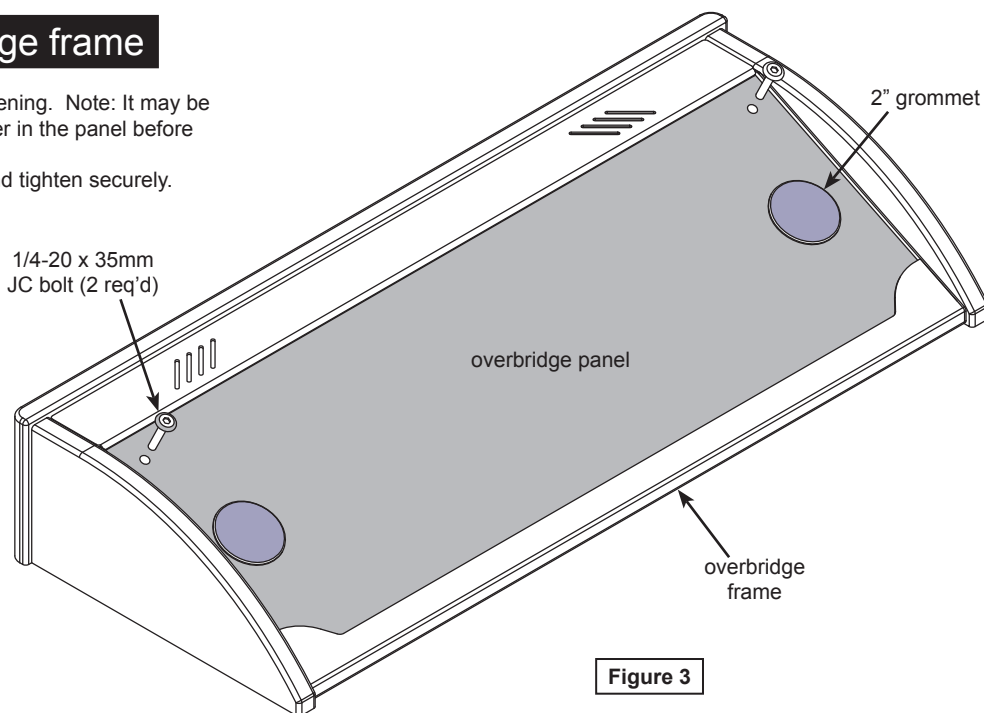

Figure 3