

Lock Only Option

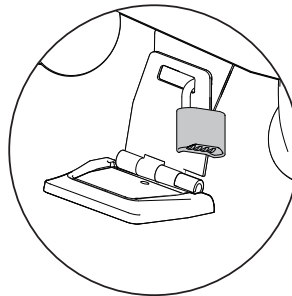

Cable and Lock

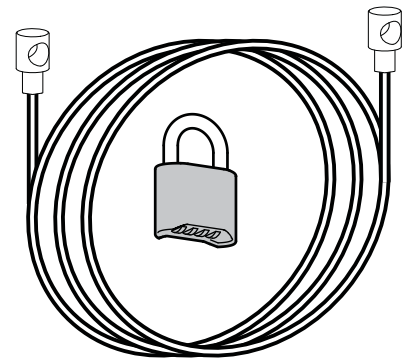

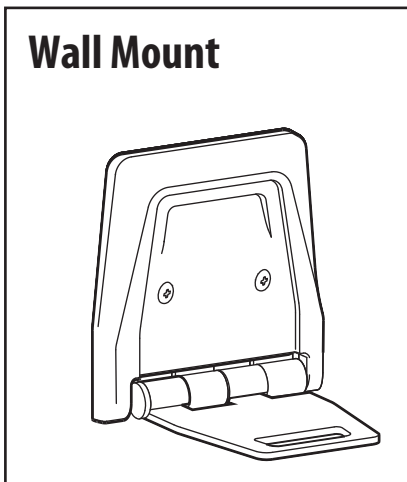

Wall Mount

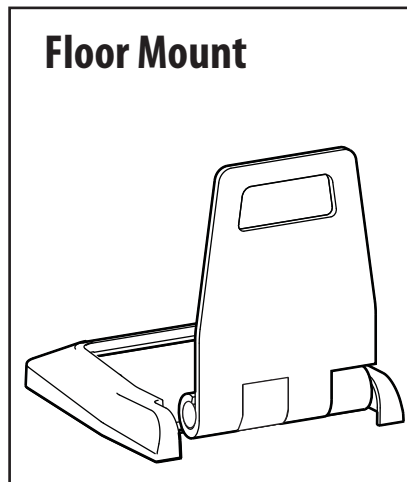

Floor Mount

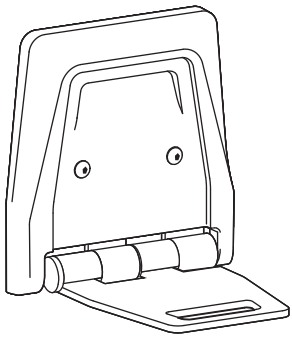
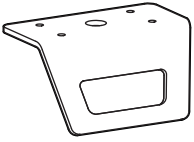
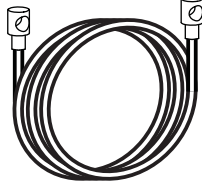
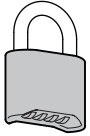
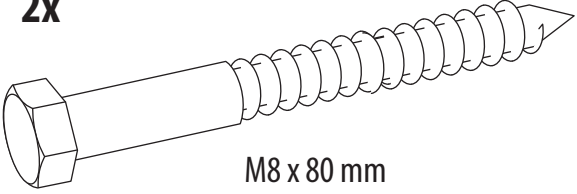
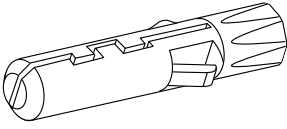

Components

	A	B		C
1	1x 	1x 	1x 	1x 
2	2x  M8 x 80 mm	2x 		4x  M4 x 10 mm 1x 

Tools



Wood
Madera
Bois
Holzbalkenträger
Massief Houten Pilaren
Due montanti in legno massiccio
 木
 木质
 나무

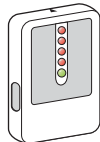

Stud Finder
Localizador de largueiros de madera
Stud Finder
Auswahl von Montagmaterial
Positiebepaler balken
Rilevatore di montanti
スタッド ファインダー
螺栓探测器
스티드 파인더

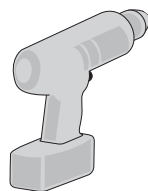
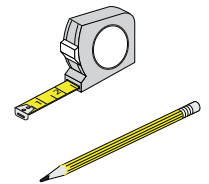

Ø 17/64" (7 mm)

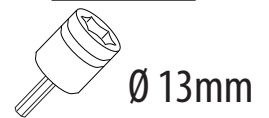

Concrete
Concreto
Béton
Massivbeton
Beton
Cemento
コンクリート
水泥质
콘크리트

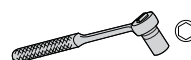
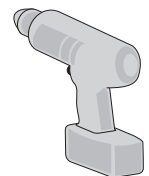
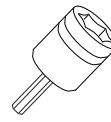
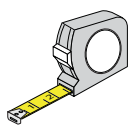
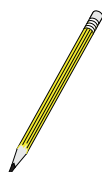
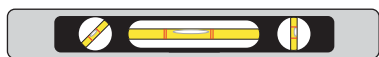

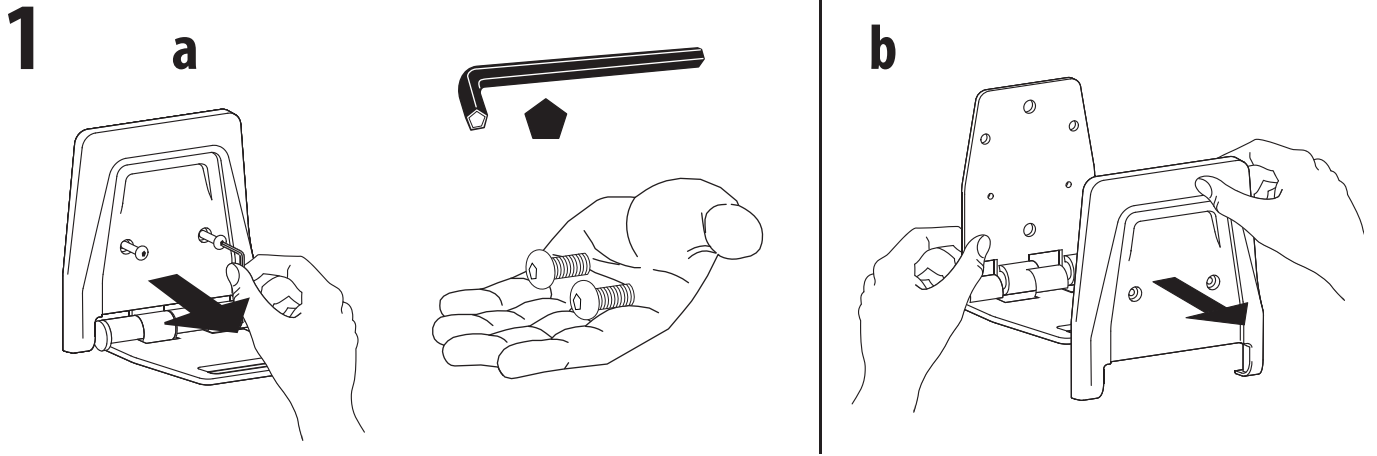

2

• **Wall Mount**

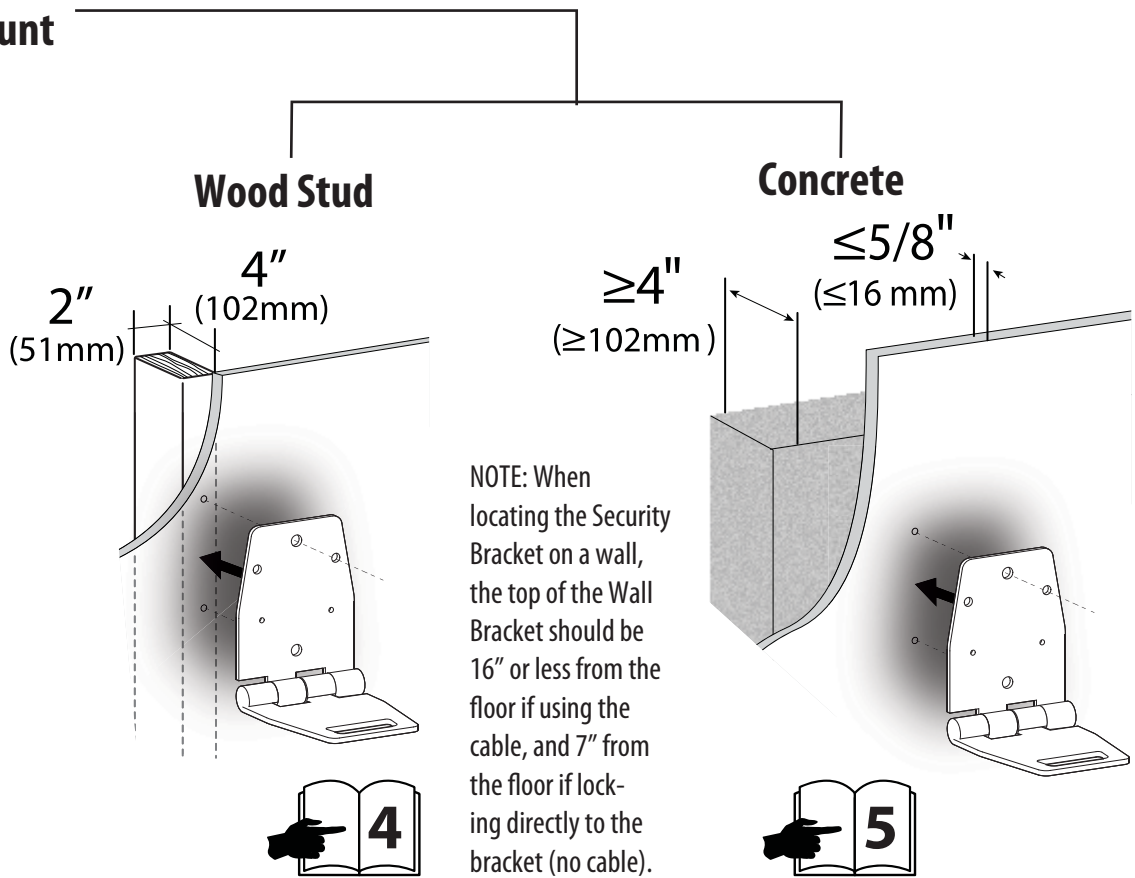

• **Floor Mount (concrete)**

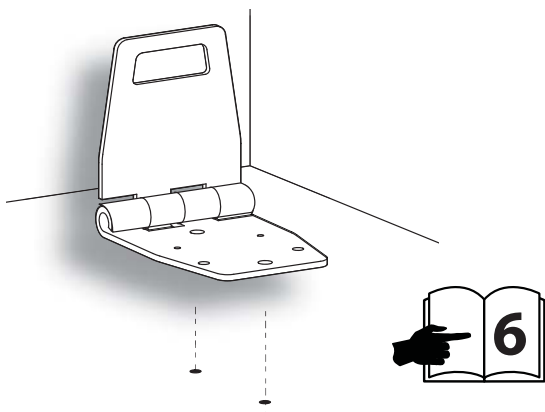

3

Wood Stud Wall Mount

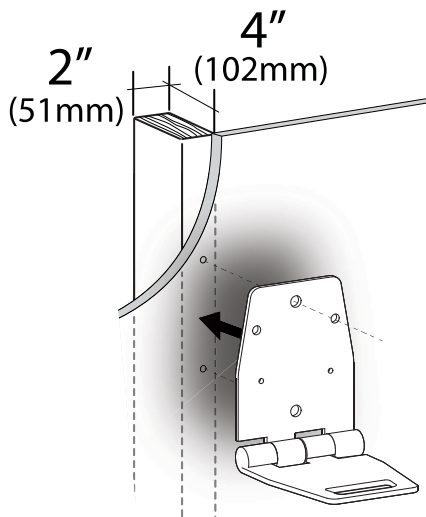

a

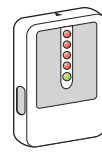

Stud Finder
Localizador de largueros de madera
Stud Finder
Auswahl von Montagematerial
Positiebepaler balken
Rilevatore di montanti
スタッド ファインダー
螺栓探测器
스티드 파인더

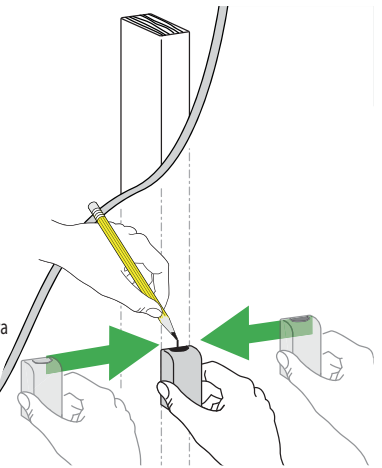

b

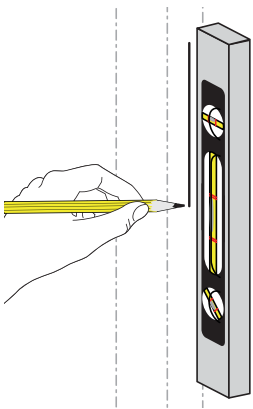

c

NOTE: When locating the Security Bracket on a wall, the top of the Wall Bracket should be 16" or less from the floor if using the cable, and 7" from the floor if locking directly to the bracket (no cable).

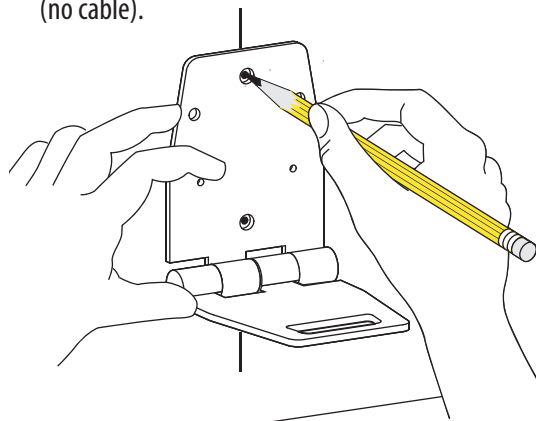

d

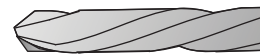

Ø 17/64" (7 mm)

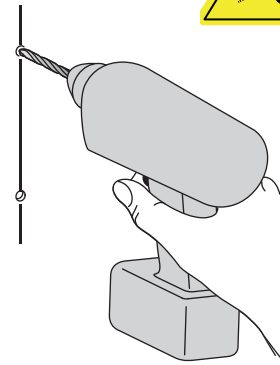

e

2x

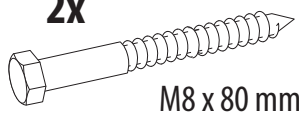

M8 x 80 mm

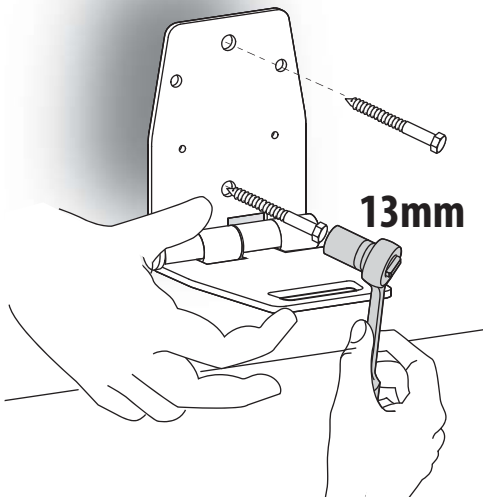

f

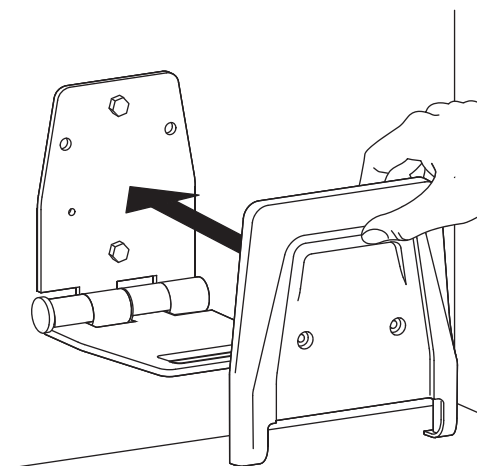

g

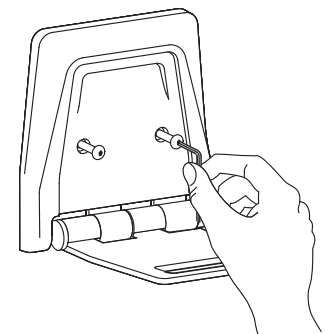
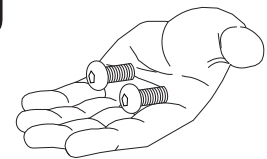

3

Concrete Wall Mount

$\geq 4"$
($\geq 102\text{mm}$)

$\leq 5/8"$
($\leq 16\text{mm}$)

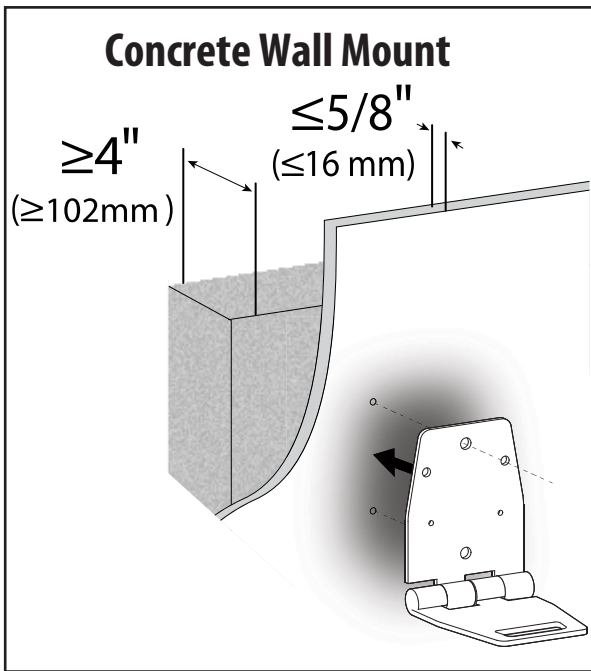

a

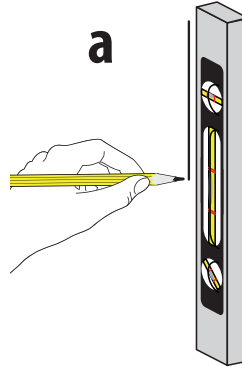

NOTE: When locating the Security Bracket on a wall, the top of the Wall Bracket should be 16" or less from the floor if using the cable, and 7" from the floor if locking directly to the bracket (no cable).

b

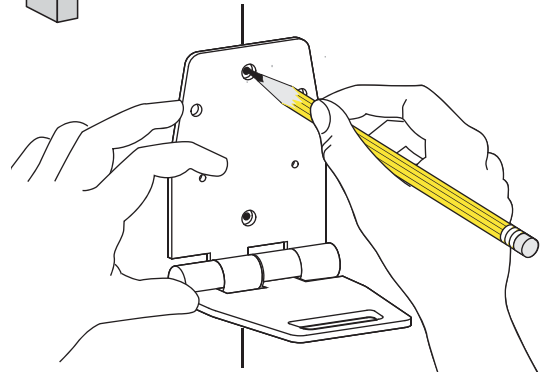

c



$\text{Ø } 3/8" (10\text{mm})$

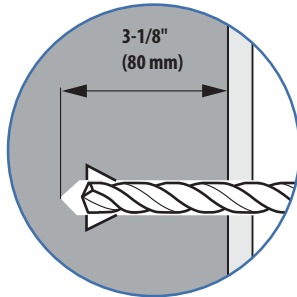
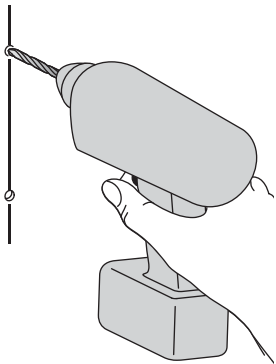

d

2x

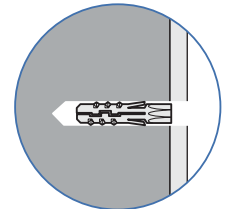
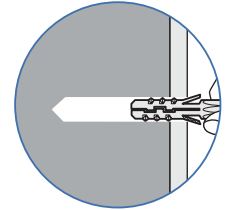
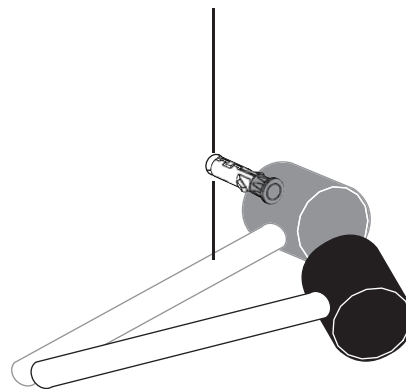
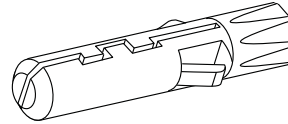

e

2x

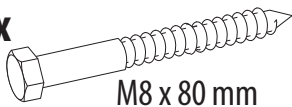

M8 x 80 mm

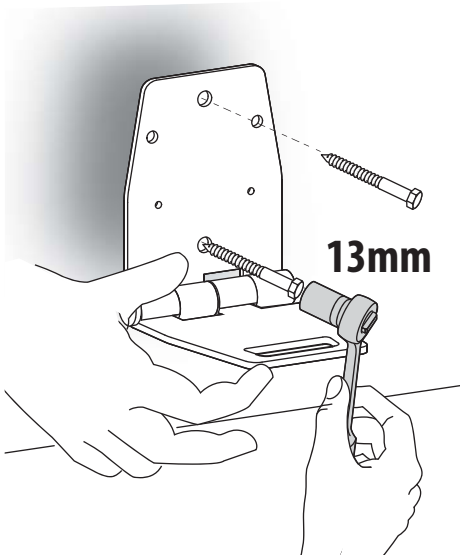

13mm

f

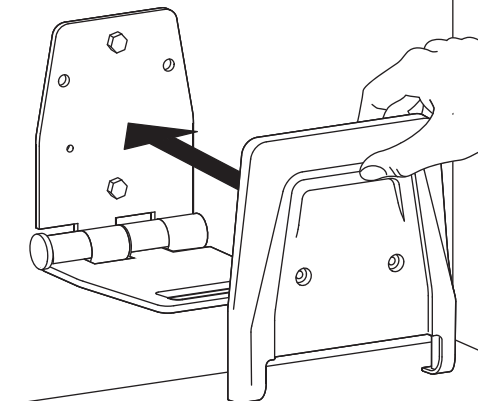

g

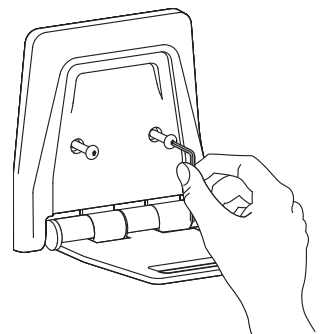
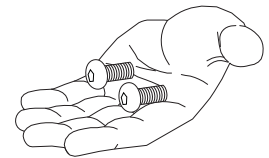

3 Floor Mount (concrete)

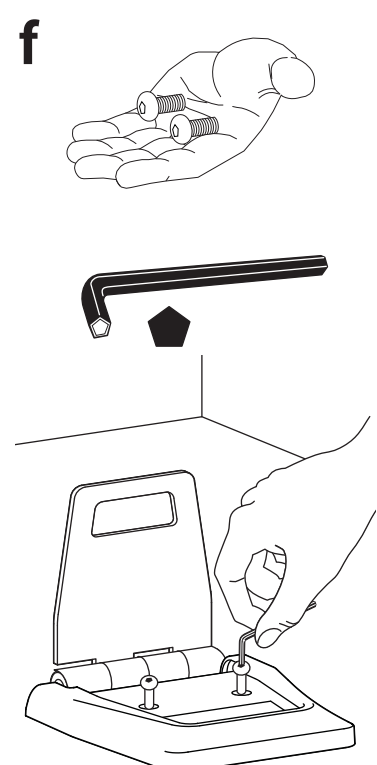
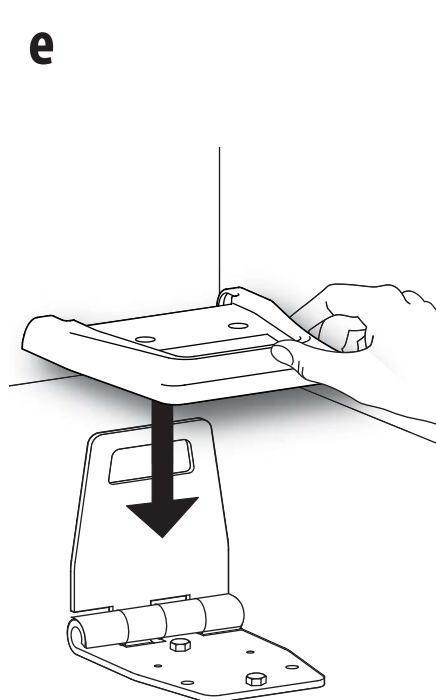
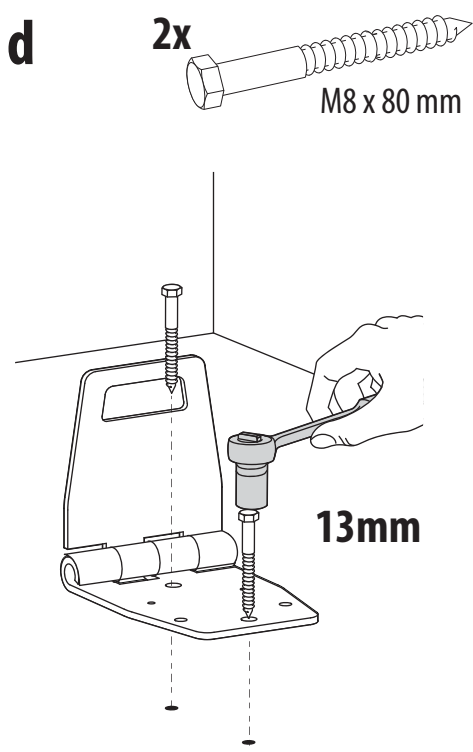
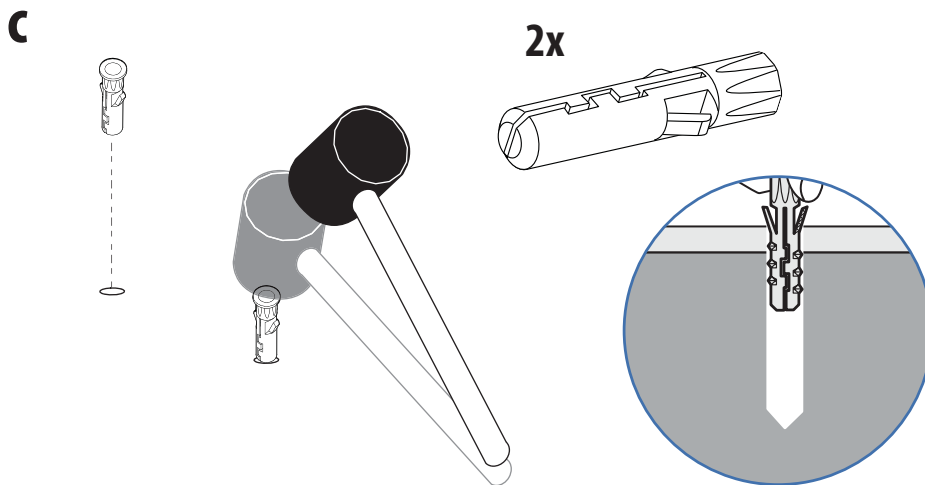
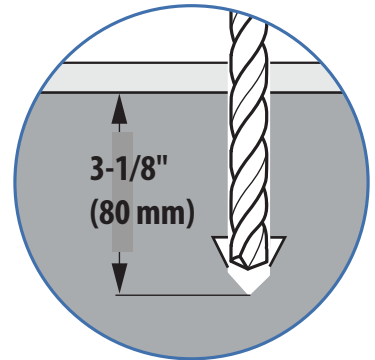
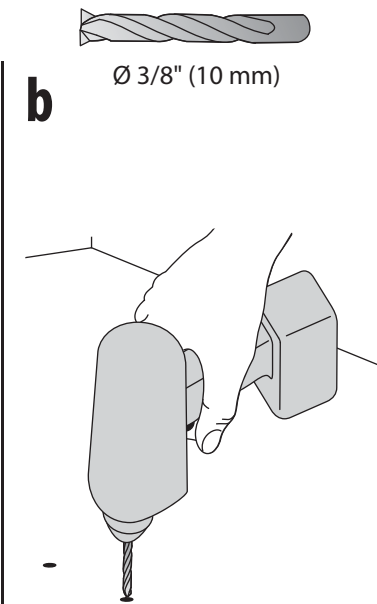
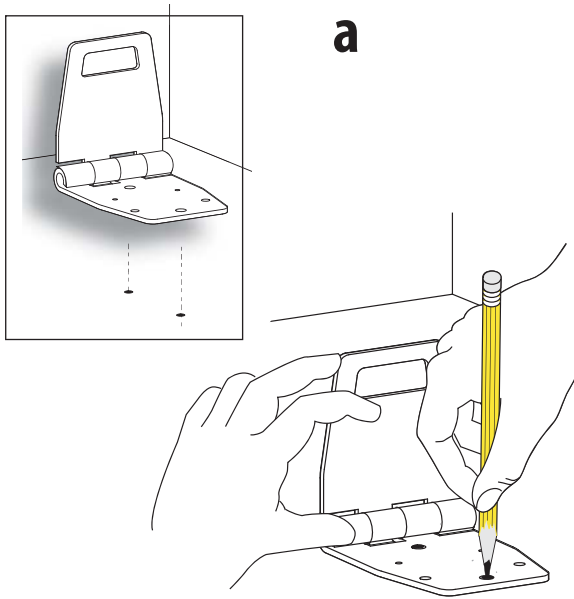

4

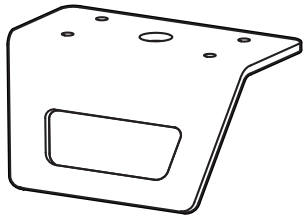

4x  M4 x 10 mm



Laptop Charging Cart

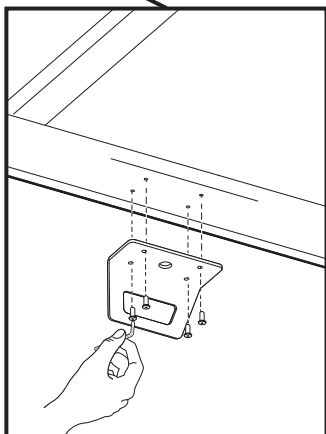
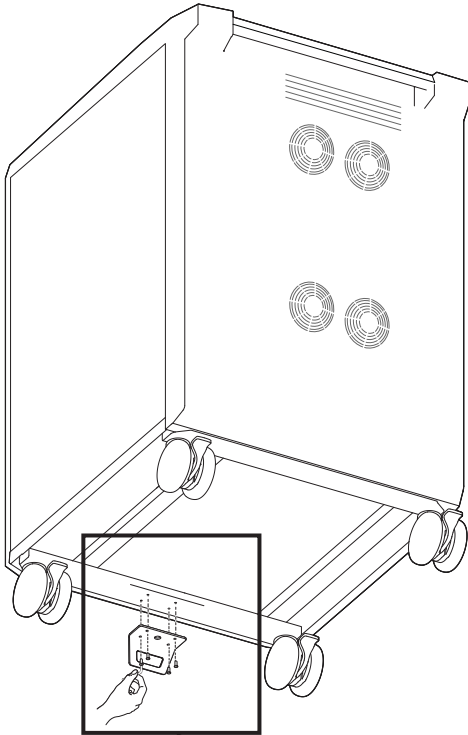
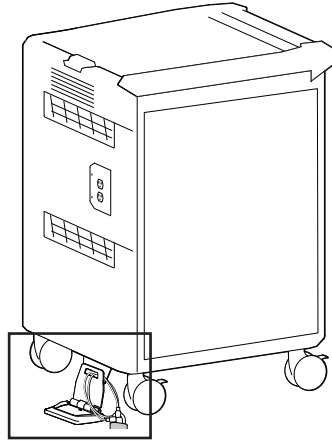

Tablet Charging Cart

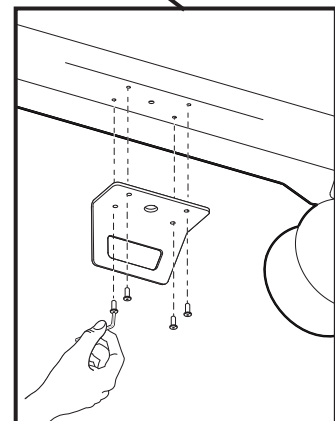
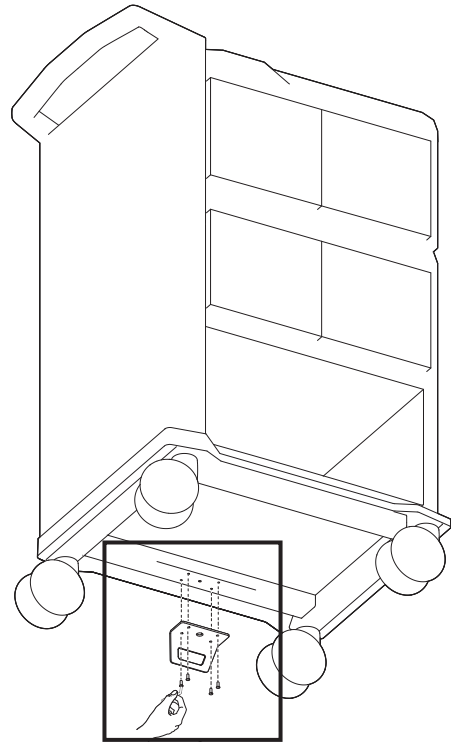
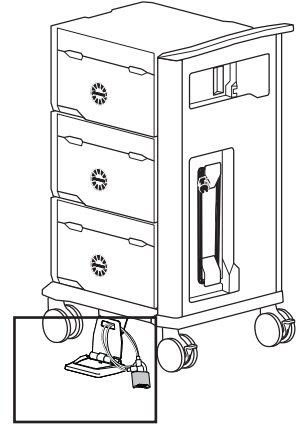

5

Lock Only

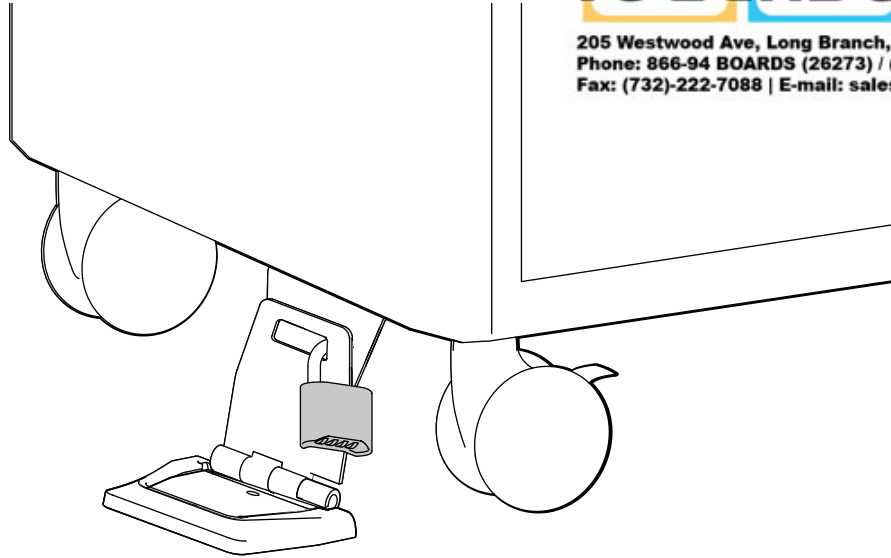
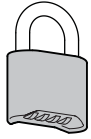

Cable and Lock

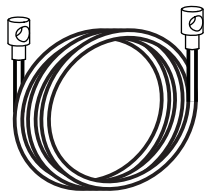

+

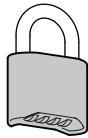

=

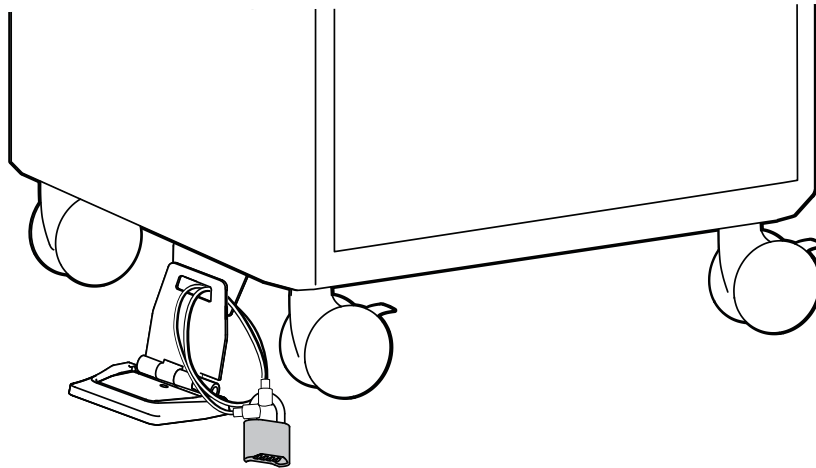
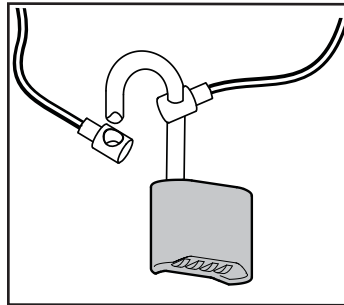

© 2013 Ergotron, Inc.
All rights reserved.

While Ergotron, Inc. makes every effort to provide accurate and complete information on the installation and use of its products, it will not be held liable for any editorial errors or omissions (including those made in the process of translation from English to another language), or for incidental, special or consequential damages of any nature resulting from furnishing this instruction and performance of equipment in connection with this instruction. Ergotron, Inc. reserves the right to make changes in the product design and/or product documentation without notification to its users. For the most current product information, or to know if this document is available in languages other than those herein, please contact Ergotron. No part of this publication may be reproduced, stored in a retrieval system, or transmitted in any form or by any means, electronic, mechanical, photocopying, recording or otherwise without the prior written consent of Ergotron, Inc., 1181 Trapp Road, Eagan, Minnesota, 55121, USA Patents Pending and Patented U.S. & Foreign. Ergotron is a registered trademark of Ergotron, Inc.

Americas Sales and Corporate Headquarters

St. Paul, MN USA
(800) 888-8458
+1-651-681-7600
www.ergotron.com
sales@ergotron.com

EMEA Sales

Amersfoort, The Netherlands
+31 33 45 45 600
www.ergotron.com
info.eu@ergotron.com

APAC Sales

Tokyo, Japan
www.ergotron.com
apaccustomerservice@ergotron.com

Worldwide OEM Sales

www.ergotron.com
info.oem@ergotron.com