

PRODUCTIONVIEW™ RACK CONSOLE

**Dual Rack Bay, Slant-top Rack System
for ProductionVIEW Controller and Rack
Mount Ears**

Part Number: 998-5000-100

Overview:

The ProductionVIEW Rack Console was specifically designed to provide a professional rack enclosure for the Vaddio™ ProductionVIEW Series of Video Consoles and provide ample and useable space for supporting video peripherals used for video productions.



ProductionVIEW Rack Console
(equipment not included)

ProductionVIEW Rack Console Features:

- 8-RU Upper rack bay (14" / 35.56cm)
- 7-RU Lower rack bay (12.25" / 31.11cm)
- Aluminum construction with attractive black powder coat finish
- 6° Slant on Lower Bay, 39° slant on upper bay for optimal viewing angles



ProductionVIEW Rack Mount Ears

Part Number: 998-5000-001 6-RU Rack Mount Ears for the ProductionVIEW Rack Console. Fits the models ProductionVIEW FX, ProductionVIEW HD, ProductionVIEW HD-SDI, ProductionVIEW HD MV, ProductionVIEW HD-SDI MV and ProductionVIEW Super Joystick.

ProductionVIEW Precision Camera Controller Rack Mount Ears

Part Number: 998-5000-002 4-RU Rack Mount Ears for the ProductionVIEW Rack Console. The 4-RU Rack Ears fit the ProductionVIEW Precision Camera Controller only.



Dimensions:

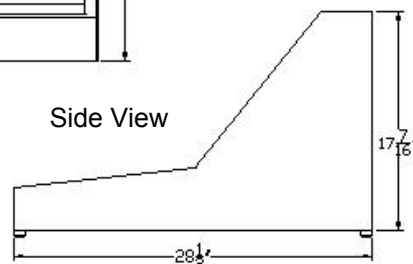
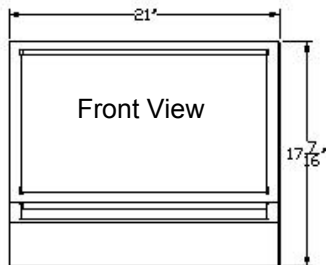

Isometric View

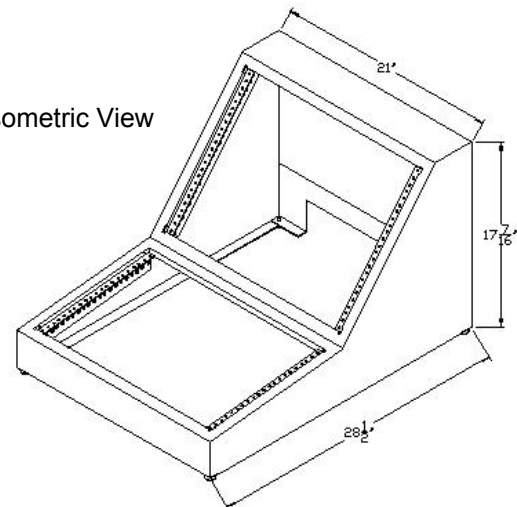



General Installation Instructions:

This section largely covers the common sense aspects of the Rack Console Installation.

- Before starting the installation, inspect the rack for damage. It is constructed out of aluminum and can be prone to concealed damage. If the rack is damaged, contact your freight carrier immediately to start the claims process.
- Before mounting product into the rack, put base on flat/level surface.
- Route all cabling out the back of the rack through the rectangular cable opening.
- Use any 10-32 threaded rack screws to secure products to rack rails (rack screws not included).
- Always use rack screws with protective washers to avoid scratching the front panel of the mounted products.
- Do not over tighten or cross thread rack screws.
- Do not attempt to take the rack apart.
- For smears or smudges, clear any dust with a blower and wipe stains with a clean, damp and soft cloth.
- Do not use abrasive chemicals or solvents.

Warranty Information:

Hardware* Warranty: One year limited warranty on all parts. Vaddio warrants this product against defects in materials and workmanship for a period of one year from the day of purchase from Vaddio. If Vaddio receives notice of such defects during the warranty period, they will, at their option, repair or replace products that prove to be defective. Please see Vaddio's Service Terms and Conditions at vaddio.com for specific details and policies.

Exclusions: The above warranty shall not apply to defects resulting from: improper or inadequate maintenance by the customer, customer applied software or interfacing, unauthorized modifications or misuse, operation outside the normal environmental specifications for the product, use of the incorrect power supply, improper extension of the power supply cable or improper site operation and maintenance.

Vaddio Customer Service: Vaddio will test, repair, or replace the product or products without charge if the unit is under warranty and is found to be defective. If the product is out of warranty, Vaddio will test then repair the product or products. The cost of parts and labor charge will be estimated by a technician and confirmed by the customer prior to repair. All components must be returned for testing as a complete unit. Vaddio will not accept responsibility for shipment after it has left the premises.

Vaddio Technical Support: Vaddio technicians will determine and discuss with the customer the criteria for repair costs and/or replacement. Vaddio Technical Support can be contacted through one of the following resources: e-mail support at support@vaddio.com or online at www.vaddio.com.

Return Material Authorization (RMA) Number: Before returning a product for repair or replacement, request an RMA from Vaddio's technical support. Provide a technician with a return phone number, e-mail address, shipping address, and product serial numbers and describe the reason for repairs or returns as well as the date of purchase and proof of purchase. Include your assigned RMA number in all correspondence with Vaddio. Write your assigned RMA number on the shipping label of the box when returning the product. All product returned for credit is subject to a restocking charge without exception.

Voided Warranty: The warranty does not apply if the original serial number has been removed or if the product has been disassembled or damaged through misuse, accident, modifications, or unauthorized repair. Cutting the power supply cable on the secondary side (low voltage side) to extend the power to the device (camera or controller) voids the warranty for that device.

Shipping and Handling: Vaddio will not pay for inbound shipping transportation or insurance charges or accept any responsibility for laws and ordinances from inbound transit. Vaddio will pay for outbound shipping, transportation, and insurance charges for all items under warranty but will not assume responsibility for loss and/or damage by the outbound freight carrier.

- If the return shipment appears damaged, retain the original boxes and packing material for inspection by the carrier. Contact your carrier immediately.

Products Not Under Warranty: Payment arrangements are required before outbound shipment for all out of warranty products.

*Vaddio manufactures its hardware products from parts and components that are new or equivalent to new in accordance with industry standard practices.



9433 Science Center Drive, Minneapolis, MN 55428
Toll Free: 800-572-2011 • Phone: 763-971-4400 • FAX: 763-971-4464
www.vaddio.com