

Quick-Connect PRO

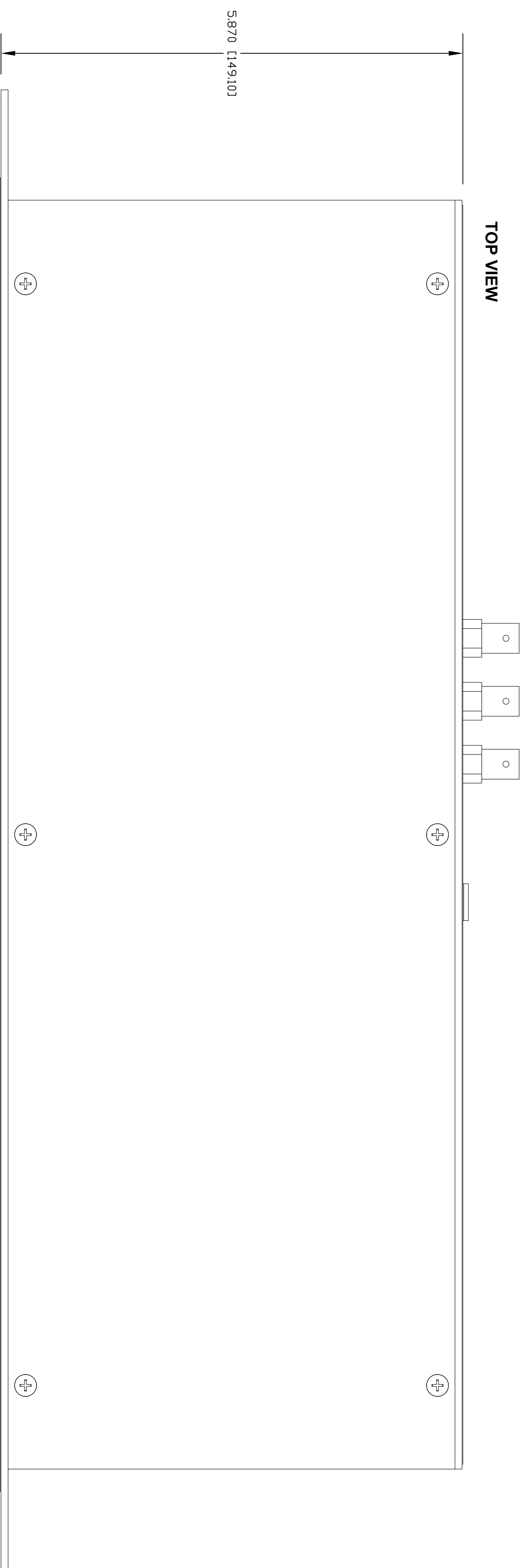

EZIM (EZCamera Interface Module)

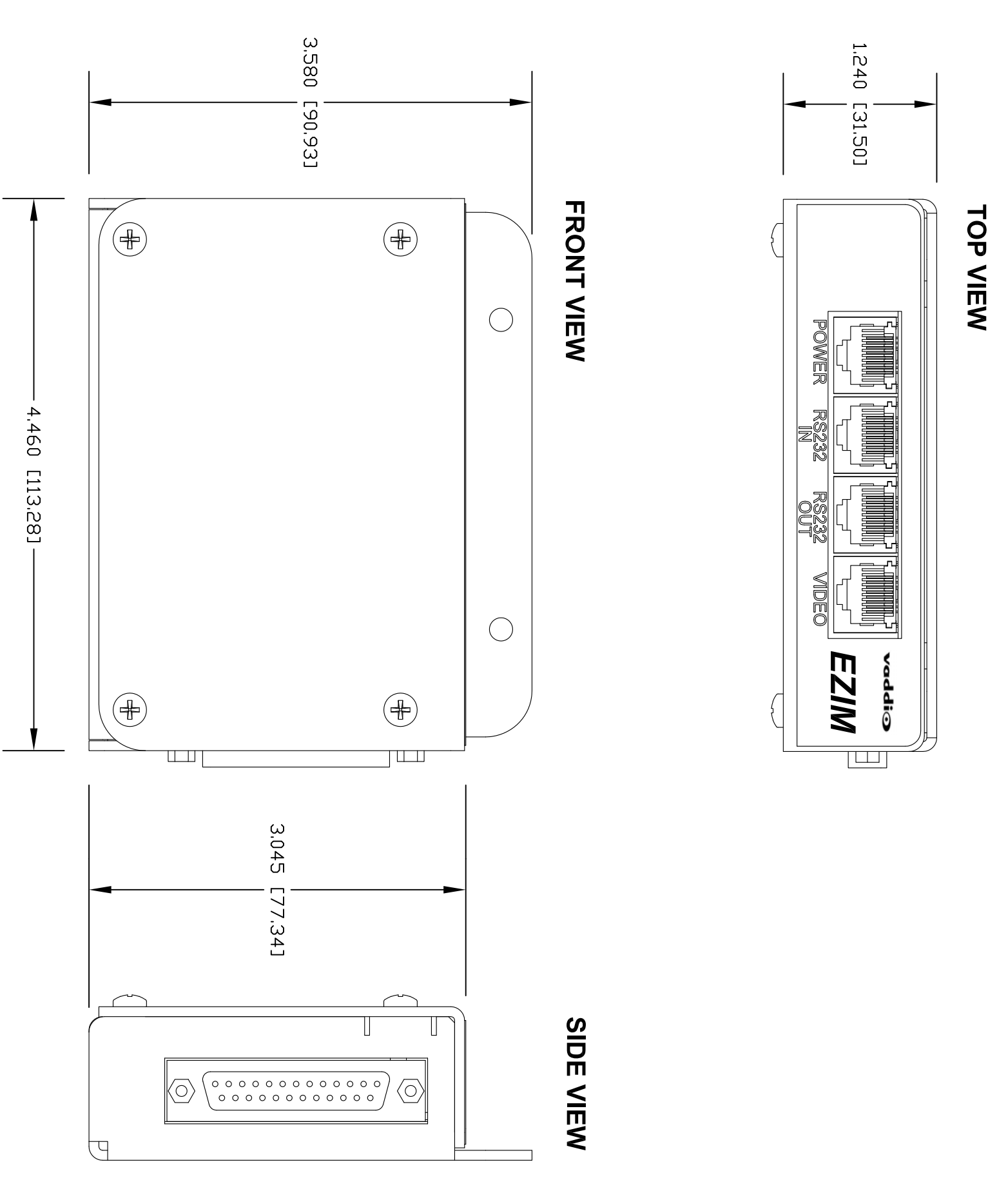

FRONT VIEW

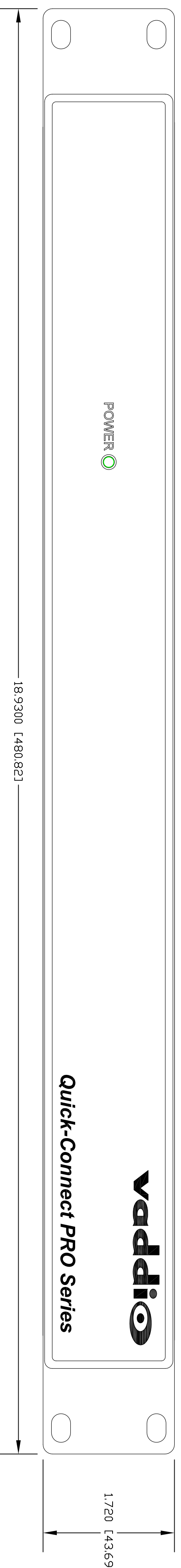

REAR VIEW

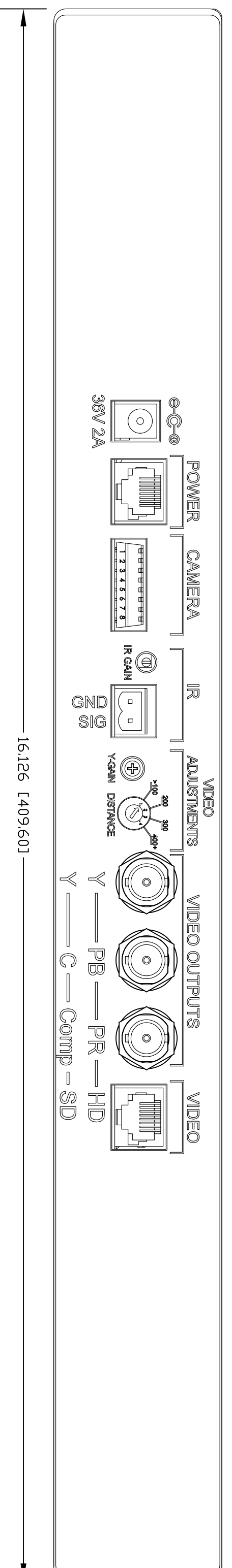

ISO VIEW

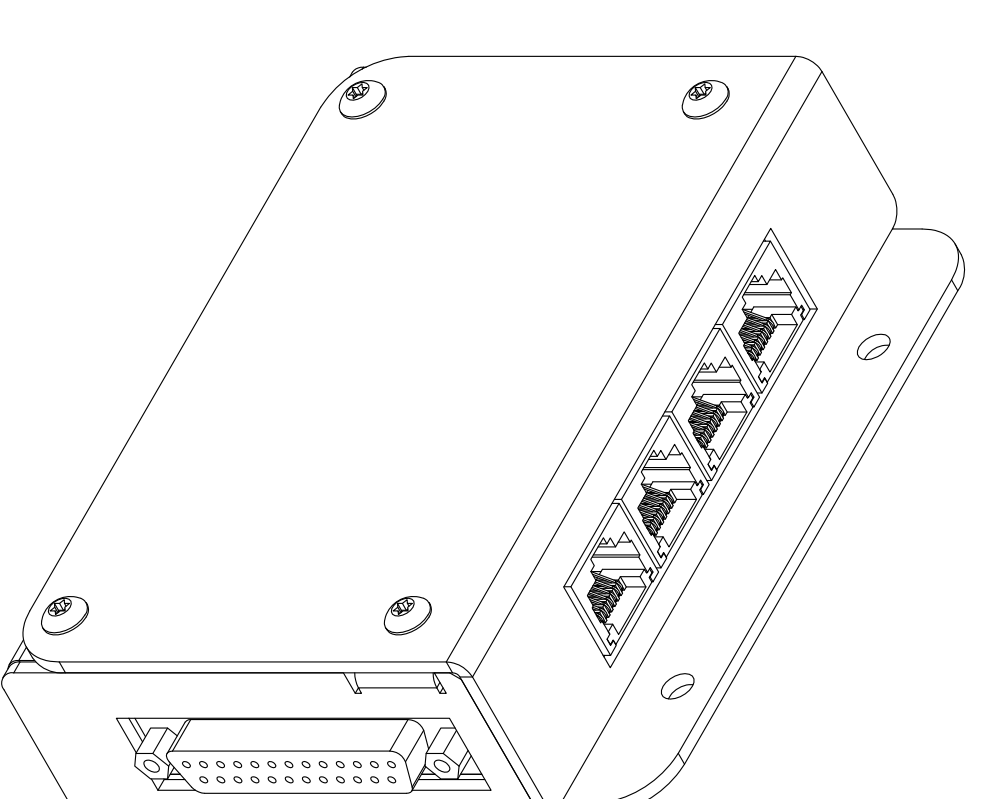

205 Westwood Ave, Long Branch, NJ 07740
 Phone: 866-94 BOARDS (26273) / (732)-222-1511
 Fax: (732)-222-7088 | E-mail: sales@touchboards.com

vaddio		GENERAL NOTES: DIMENSIONS ARE IN INCHES UNLESS OTHERWISE NOTED. DIMENSIONS ARE TO FACE UNLESS OTHERWISE NOTED. DIMENSIONS ARE TO CENTER UNLESS OTHERWISE NOTED. DIMENSIONS ARE TO DIMENSION LINE UNLESS OTHERWISE NOTED. DIMENSIONS ARE TO DIMENSION LINE UNLESS OTHERWISE NOTED. DIMENSIONS ARE TO DIMENSION LINE UNLESS OTHERWISE NOTED. DIMENSIONS ARE TO DIMENSION LINE UNLESS OTHERWISE NOTED.	
Quick-Connect PRO (998-1105-009) & EZIM (998-6700-001)			
FOR HD AND SD RESOLUTION CAMERAS			
DRAWN	CHECKED	APPROVED	DATE
RAR		RAR	02/04/10
THIS DRAWING, INCLUDING ALL SUBJECT MATTERS INDICATED THEREON OR DERIVED THEREFROM, IS THE PROPERTY OF VADDDIO. ALL RIGHTS ARE RESERVED. NO PART OF THIS DRAWING IS TO BE REPRODUCED OR TRANSMITTED IN ANY FORM OR BY ANY MEANS, ELECTRONIC OR MECHANICAL, INCLUDING PHOTOCOPYING, RECORDING, OR BY ANY INFORMATION STORAGE AND RETRIEVAL SYSTEM, WITHOUT PERMISSION IN WRITING FROM VADDDIO.			
TITLES	SCALE	DRAWING NO.	REV
CES - BLACK POWDERCOAT	1:1	1105-009	B
COMMENTS	SIZE	PLOT IN POLAROID OR PDF - NOT INCLUDED	
	D		