

Touchboards

205 Westwood Ave, Long Branch, NJ 07740
Phone: 866-94 BOARDS (26273) / (732)-222-1511
Fax: (732)-222-7088 | E-mail: sales@touchboards.com

vaddio™

THE ART OF EASY



Integrator's Complete Guide for **RoboSHOT HD-SDI PTZ Cameras**

Document 342-1076 Rev. A

Contents

Overview	1
Unpacking the Camera	3
RoboSHOT 12 HD-SDI Cameras	3
RoboSHOT 30 HD-SDI Cameras	4
A Quick Look at the Camera	5
Front of the camera	5
Back of the camera	6
Switch Settings	6
Video resolution	7
Camera settings	8
Installation	9
Before You Install the Camera	9
Don't void your warranty!	9
Cabling notes	9
Installing the Camera Mount and the Camera	10
Connecting the Camera	11
In a Small Space	11
In a Larger Space	11
Powering up the camera	11
Configuring and Controlling the Camera	12
Vaddio IR Remote Commander	12
Quick Reference	12
Details	13
To store a preset using the IR Remote Commander:	13
Web Interface	14
Compatible Web Browsers	14
User Access	15
Administrative access	15
Web Interface Cheat Sheet	16
Web Tasks for All Users: Camera Control	17
Web Tasks for Administrators: Configuring Network Settings	21
Web Tasks for Administrators: Adding Room Information to the Screen	22
Web Tasks for Administrators: Managing Access and Passwords	23
Web Tasks for Administrators: Setting Camera Behaviors and Adjustments	24
Web Tasks for Administrators: Configuring Streaming Settings	26
Web Tasks for Administrators: System Reboots, Resets, and Updates	28
Web Tasks for Administrators: Viewing Diagnostic Logs	30
Web Tasks for Administrators: Contacting Vaddio Technical Support	31
Telnet Serial Command API	32
camera home	32

camera pan	33
camera tilt	33
camera zoom	34
camera focus	35
camera preset	36
camera ccu get	37
camera ccu set	38
camera ccu scene	39
camera standby	39
streaming settings	40
network ping	41
network settings get	41
system reboot	41
system factory-reset	42
history	43
version	43
help	44
exit	44
RS-232 Serial Communication	45
RS-232 Command List	45
RS-232 Inquiry Command List	53
Command Setting Values – Exposure Control	57
General Specifications	60
Troubleshooting and Care	63
Operation, Storage, and Care	64
Compliance Statements and Declarations of Conformity	65
FCC Part 15 Compliance	65
ICES-003 Compliance	65
European Compliance	66
Warranty Information	67
Index	68

Overview

This manual covers the RoboSHOT 12 HD-SDI and RoboSHOT 30 HD-SDI robotic PTZ cameras:

- RoboSHOT 12 HD-SDI, North America – part number 999-9930-000
- RoboSHOT 12 HD-SDI, international – part number 999-9930-001
- RoboSHOT 30 HD-SDI (black), North America – part number 999-9933-000
- RoboSHOT 30 HD-SDI (black), international – part number 999-9933-001
- RoboSHOT 30 HD-SDI (white), North America – part number 999-9933-000W
- RoboSHOT 30 HD-SDI (white), international – part number 999-9933-001W



The enterprise-class, high-definition PTZ RoboSHOT HD-SDI conferencing cameras with HD-SDI, HDMI, and H.264 IP streaming provide a substantial price/performance improvement over other SDI cameras available today, with very high quality imaging, fine detail and exceptional color reproduction.

The RoboSHOT HD-SDI cameras have a PoE+ gigabit Ethernet port, providing both power and IP network connectivity. The intuitive browser-based interface allows you to control the camera's functions from your browser – from anywhere in the world – while monitoring the RSTP, H.264 IP video stream using any standards-based media viewer. This feature is perfect for enterprise remote management, network operating centers and overall IT control. Telnet, IR Remote and RS-232 control are also available to satisfy your system control requirements. Available H.264 streaming resolutions range from 352 x 288 to 1080p.

The RoboSHOT 12 features a 12X optical zoom with a 73° wide horizontal field of view – perfect for small to medium sized conference rooms, training rooms or classrooms and provides incomparable support for applications including, UC conferencing, videoconferencing, distance learning, lecture capture, telepresence and more.

With 30X optical zoom power with an impressive 2.3° tele end and 65° wide field of view, the RoboSHOT 30 is ideal for medium to large venues such as houses of worship, large auditorium A/V systems, live event theatres, IMAG for performances, large lecture theatres with lecture capture and more.

The Exmor® image sensor, multi-element glass lens and image signal processor (ISP) are the real magic behind these cameras' awesome video performance characteristics. The latest generation Exmor® 1/2.8", 2.38 Megapixel, Full HD (native 1080p/60) high-speed, low noise CMOS image sensor combined with the new ISP produces vivid, realistic color with extremely fast, razor-sharp automatic focus and iris routines.

The proprietary Tri-Synchronous Motion™ algorithm moves the RoboSHOT cameras on the pan, tilt and zoom axes simultaneously, calculating the position and velocity of the movements between presets so pan, tilt and zoom arrive at the preset subject simultaneously, allowing smooth and manageable on-air camera movements. No more waiting for the pan/tilt motion to stop before starting the zoom.

Smooth, silent brushless DC direct-drive motors provide ultra-accurate and fast camera positioning and are capable of the slowest of crawls – perfect for on-air use.

Control the camera the way you prefer:

- Use your browser to access the camera's web interface
- Use the IR remote
- Connect via a Telnet session
- Connect directly via RS-232 serial port.

The features, flexibility and value of RoboSHOT cameras are unparalleled in today's PTZ camera market. All this, and they're made in the USA, at Vaddio HQ in Minnetonka, Minnesota.

Unpacking the Camera

Make sure you received all the items you expected. Here are the packing lists for the RoboSHOT HD-SDI cameras.

RoboSHOT 12 HD-SDI Cameras

RoboSHOT 12 HD-SDI (North America) – part number 999-9930-000

Includes:

- One (1) RoboSHOT 12 HD-SDI Camera
- One (1) Thin Profile Wall Mount with Mounting Hardware (535-2000-240)
- One (1) IR Remote Commander (998-2100-000)
- One (1) EZCamera Control Adapter (998-1001-232)
- One (1) 12 VDC, 3.0 Amp Switching Power Supply
- One (1) AC Cord Set for North America
- One (1) Quick Setup Guide



RoboSHOT 12 HD-SDI (International) – part number 999-9930-001

Includes:

- One (1) RoboSHOT 12 HD-SDI Camera
- One (1) Thin Profile Wall Mount with Mounting Hardware (535-2000-240)
- One (1) IR Remote Commander (998-2100-000)
- One (1) EZCamera Control Adapter (998-1001-232)
- One (1) 12 VDC, 3.0 Amp Switching Power Supply
- One (1) Euro Power Cord
- One (1) UK Power Cord
- One (1) Quick Setup Guide



RoboSHOT 30 HD-SDI Cameras

RoboSHOT 30 HD-SDI (North America, black) – part number 999-9933-000

RoboSHOT 30 HD-SDI (North America, white) – part number 999-9933-000W

Includes:

- One (1) RoboSHOT 30 HD-SDI Camera
- One (1) Thin Profile Wall Mount with Mounting Hardware, black or white depending on camera color (535-2000-240 or 535-2000-240W)
- One (1) IR Remote Commander (998-2100-000)
- One (1) EZCamera Control Adapter (998-1001-232)
- One (1) 12 VDC, 3.0 Amp Switching Power Supply
- One (1) AC Cord Set for North America
- One (1) Quick Setup Guide



OR



RoboSHOT 30 HD-SDI (International, black) – part number 999-9933-001

RoboSHOT 30 HD-SDI (International, white) – part number 999-9933-001W

Includes:

- One (1) RoboSHOT 30 HD-SDI Camera
- One (1) Thin Profile Wall Mount with Mounting Hardware, black or white depending on camera color (535-2000-240 or 535-2000-240W)
- One (1) IR Remote Commander
- One (1) EZCamera Control Adapter (998-1001-232)
- One (1) 12 VDC, 3.0 Amp Switching Power Supply
- One (1) Euro Power Cord
- One (1) UK Power Cord
- One (1) Quick Setup Guide



OR



Download all product documentation from support.vaddio.com.

A Quick Look at the Camera

The RoboSHOT 12 and RoboSHOT 30 cameras are similar. The RoboSHOT 12 is the camera on the left in the photo. Differences are noted below.

Front of the camera



- **Camera and Zoom Lens:** The RoboSHOT 12 and 30 models use different optical components.
 - The RoboSHOT 12 features a 12X optical zoom lens (12X in Super-Wide mode and 10X in normal mode) that is built around an Exmor 1/2.8-Type, high-speed, low noise image sensor with a total of 2.38 Megapixels for exceptionally precise HD video image acquisition in a small to medium sized conference room.
 - The RoboSHOT 30 has a powerful 30X optical zoom lens, best suited to a medium to large room. It uses the same Exmor image sensor as the RoboSHOT 12.
- **IR Sensors:** Sensors in the front of the camera base receive signals from the IR Remote Commander.
- **Status indicator:** The multi-colored LED indicates the camera's current state.
 - Purple – Boot-up and Standby modes.
 - Blue – normal operation and is a power on, ready condition.
 - Blinking blue – the camera has received a valid IR command.
 - Red – Tally function; shows that the camera is on-air.
 - Blinking red – fault condition.
 - Yellow – firmware update is in progress.

Caution

Do not remove power or reset the camera while the indicator is yellow, showing a firmware update in progress. Interrupting a firmware update can make the camera unusable.

- **Camera Base:** Cast zinc alloy base for strength and stability, powder coated for toughness with fine texture.
- **Logo:** Really Cool Logo Badge (RCLB) is located on the IR Window.

Back of the camera

Rear panel connections are identical for both models. This photograph shows the RoboSHOT 12.



From left to right:

- **12 VDC 3.0 A power connector:** Connect only the power supply shipped with the camera.
- **Network RJ-45 connector:** PoE+ Gigabit Ethernet port allows the camera to be controlled using the web interface or via a Telnet session.
- **HD Video Select switch:** Select the HD video output resolution.
- **Camera Settings DIP switches:** Settings for IR remote frequency, baud rate and image flip. See "Switch Settings" below for more information.
- **HD-SDI connector:** HD-SDI video output.
- **HDMI connector:** HDMI video output.
- **RS-232 connector:** accepts modified VISCA protocol for camera control over a Cat-5e cable.

Caution:

Use the power supply shipped with the camera. Using a different power supply may create an unsafe operating condition or damage the camera, and will void the warranty.

Switch Settings

The RoboSHOT HD-SDI cameras use a rotary switch to set the HD video resolution of the HD-SDI and HDMI outputs, and a set of DIP switches that determine certain camera functions. A label on the bottom of the camera provides a quick reference for setting the switches.

Video resolution

Set the desired available HD output resolution for the camera with the rotary switch. Switch positions 9 through D are not used.

Switch position	Resolution
0	720p/59.94
1	1080i/59.94
2	1080p/59.94
3	720p/60
4	1080i/60
5	1080p/60
6	720p/50
7	1080i/50
8	1080p/50
9 - D	Not used
E	1080p/30
F	1080p/25

Camera settings

Use the DIP switch array to set other camera behaviors.

Note

When the camera is right side up, switches are in their default positions when they are up.

Camera identification: If a Vaddio remote control will be used with the camera: **IR Frequency Selection:**The IR Remote Commander can control up to three cameras in the same room with different IR frequencies. Use **switches 1 and 2** to select the frequency to identify the camera as camera 1, 2, or 3; then use the Camera Select buttons at the top of the remote to select the camera you want to control.

IR: Leave **switch 3** in the default up position if the IR remote will be used.

Inverted operation: If mounting the camera upside-down, set **switch 4** (IMAGE FLIP) ON.

Super Wide Mode (RoboSHOT 12 only): To set Super-wide mode for the RoboSHOT 12 HDMI, set **switch 5** ON. This gives a 12X, 73° horizontal angle of view. Normal mode produces a 67.2° horizontal field of view (HFOV). Super-wide mode is not available on RoboSHOT 30 cameras.

RS-232 Serial Baud Rate: Set the baud rate for RS-232 communication using **switch 6**. Most applications use 9600bps (switch 6 OFF). The 9600 bps setting works best with Cat-5e over distance. Use the 38,400 bps setting for short control lines only.

Switch 7 is not currently used.

Switch 8 is not currently used.

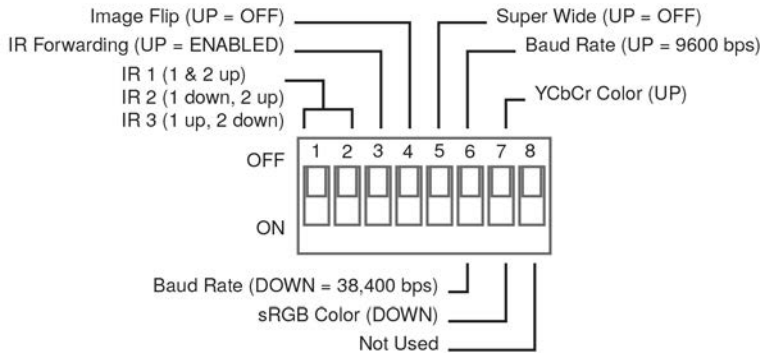

Installation

This section covers siting the camera, installing the mount, and installing the camera.

Before You Install the Camera

All RoboSHOT cameras include a Thin Profile Wall Mount for...wall mounting the camera. There are options for IN-Wall™ mounts and IN-Ceiling™ Half-Recessed as well. Contact us if you don't have the camera mount you need.

- Choose a camera mounting location that will optimize camera performance. Consider camera viewing angles, lighting conditions, line-of-sight obstructions, and in-wall obstructions where the camera is to be mounted.
- Ensure that the camera body can move freely and point away from the ceiling and lights. Cameras generally don't like to be swamped with light and nobody sits on the ceiling anyway.
- Follow the installation instructions included with the camera mount.

Don't void your warranty!

Caution

This product is for indoor use. Do not install it outdoors or in a humid environment without the appropriate protective enclosure. Do not allow it to come into contact with any liquid.

Use only the power supply included with this product. Using a different one will void the warranty, and could create unsafe operating conditions or damage the product.

Do not install or operate this product if it has been dropped, damaged, or exposed to liquids. If any of these things happen, return it to Vaddio for safety and functional testing.

All information about this product is available for download at www.vaddio.com/support – no cost, no registration required.

DomeVIEW enclosures are available to allow outdoor installation of RoboSHOT cameras. Learn more at www.vaddio.com/products.

Cabling notes

For RS-232 cabling, use Cat-5 or Cat-5e/6 cable and standard RJ-45 connectors (568B termination) from the camera's RS-232 Port to the controller's RS-232 port. If the camera is connected to a third-party control system (such as AMX or Crestron), a DE-9F (sometimes called DB-9F) adapter is supplied.

We recommend using high-quality connectors and a high-quality crimping tool.

Note

Do not use pass-through RJ-45 connectors. These can cause intermittent connections and degraded signal quality, resulting in problems that may be hard to diagnose. Use standard RJ-45 connectors and test all cables for proper pin-outs and continuity before you connect them to Vaddio products.



Installing the Camera Mount and the Camera

You can install the camera wall mount to a 2-gang wall box or directly to the drywall.

- If you mount it to drywall, use the wall anchors provided with the wall mount.
- If you mount it to a wall box, use the cover plate screws supplied with the wall box.

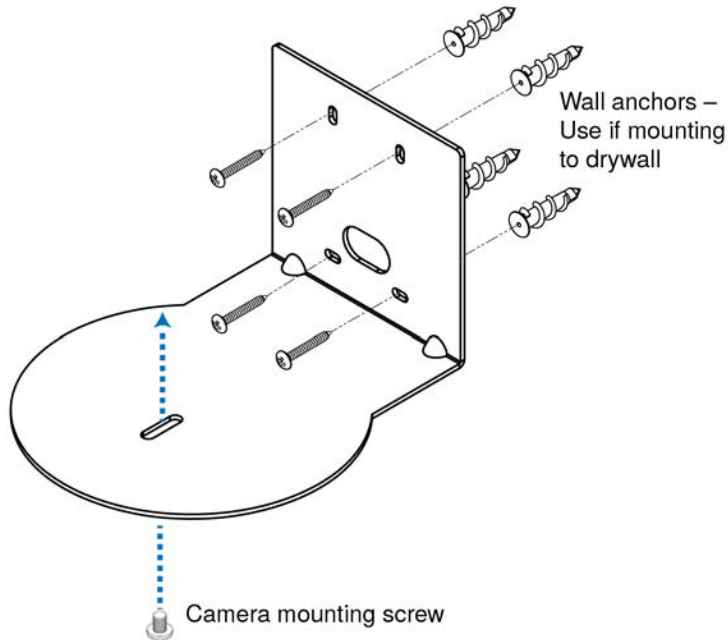

Caution

Before you start, be sure you can identify the network and RS-232 cables correctly. Connecting a cable to the wrong port can result in equipment damage.

1. Route the cables through the hole in the back of the mount, and install the mount on the wall or attach it to the wall box. Leave the screws loose enough to adjust the position of the mount.
2. Level the mount and tighten the mounting screws.
3. Check the level again to avoid any of those weird Batman camera angles.
4. Connect the cables to the camera.
5. Place the camera on the mount.
6. Attach the camera to the mount using the 1/4"-20 x .375 mounting screw supplied with the camera.

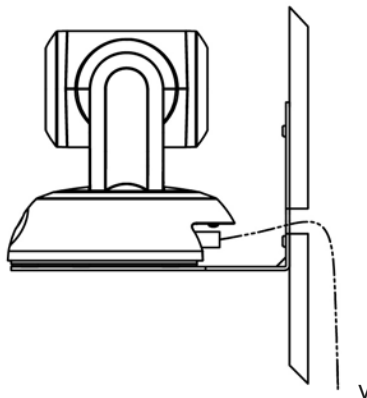

Connecting the Camera

Here are two examples of how the camera might be set up. This information is also available on the Quick-Start Guide provided with the camera.

In a Small Space

This example uses the camera's power supply.

Local Power Supply

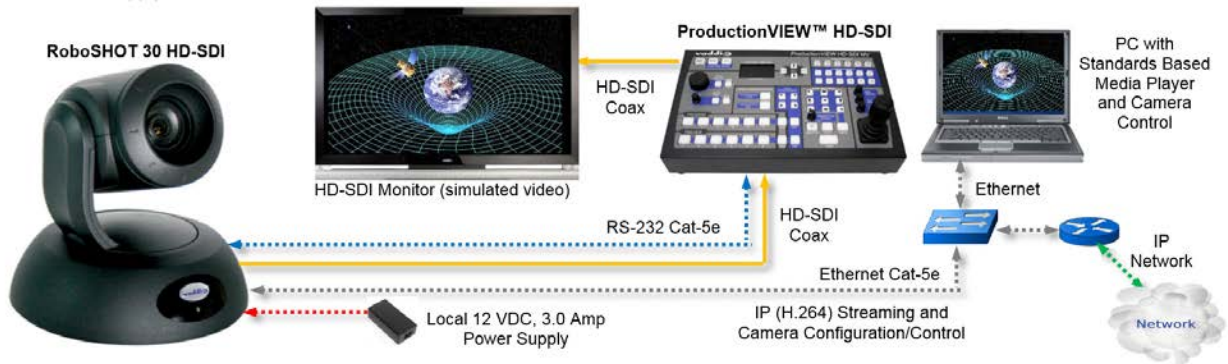

In a Larger Space

This example uses PoE and a mid-span power injector.

PoE+ Power



Powering up the camera

Connect the supplied 12 VDC, 3.0 Amp power supply to a power outlet.

The camera will wake up and initialize. This will take a few seconds. When an image is available, the camera is ready to accept control information.

Configuring and Controlling the Camera

You can control the camera using the IR remote, web interface, Telnet session, or RS-232 command line – but not at the same time. We recommend that you pick one and run with it.

Vaddio IR Remote Commander

The remote provides basic camera control for end users.

Quick Reference

What do you need to do?	Button(s)
Power on or standby	Power (green button at top right)
Select the camera to control (if this remote controls more than one)	Camera Select buttons 1 through 3 (second row on the remote)
Discover the camera's IP address	Data Screen button (top left)
Move the camera	Arrow buttons and Home button (dark red)
Move the camera to a preset position	Position Preset buttons 1 through 6 (bottom two rows)
Focus the camera	Auto Focus button (near arrow buttons) Manual Focus buttons Near and Far (below Zoom Speed buttons)
Control zoom speed	Zoom Speed buttons - Slow T and W , Fast T and W for telephoto and wide-angle modes (light gray)
Adjust for excess light behind the camera's subject	Back Light button (top center)

Details

The Vaddio remote provides the following functions:

Power – Switch the selected camera on or off.

Power indicator – Shows power on, IR transmission, and battery level.

Back Light – Use or turn off backlight compensation.

Data Screen – Display the camera's IP address and MAC address.

Camera Select – In multi-camera installations, selects the camera to be controlled. See on page for information on configuring the camera as camera 1, 2, or 3.

Pan/Tilt (arrow button) controls and Home button – Control the camera's position.

Rev. Pan and Std. Pan – Control how the camera responds to the arrow buttons. Helpful for ceiling-mounted cameras.

Pan/Tilt Reset – Return the camera to its default position.

Auto Focus – Switch between automatic focus and manual focus.

Zoom Speed – select Slow or Fast movements for telephoto and wide-angle shots.

- **T** (slow and fast) – Telephoto
- **W** (slow and fast) – Wide-angle

Manual Focus – Toggle manual focus on or off.

Near (-) adjustment – Moves the focus nearer when in manual focus mode.

Far (+) adjustment – Moves the focus farther when in manual focus mode.

Position Presets 1 through 6 – Move the camera to a predefined position.

Preset – Save the camera's current position as one of the numbered presets.

Reset – Clear the saved position presets.

The web interface offers greater control over camera movements to presets (such as setting the speed for Tri-Synchronous Motion), and provides additional presets.

To store a preset using the IR Remote Commander:

Position the camera. Then hold down the **Preset** button and press one of the numbered preset buttons.



Web Interface

RoboSHOT cameras provides a web interface to allow control of the attached camera via an Ethernet network connection. The web interface provides more control over the camera for the user, along with administrative tasks such as setting passwords, changing the IP address, viewing diagnostics, installing firmware updates, and more!

The web interface allows administrative and user-level camera control.

- Administrative access – The default username is `admin` and the password is `password`. The admin has access to all pages of the web interface.
- User access – The default username is `user` and the password is `password`. Only the camera control page is available with user-level access.

If the LAN has a DHCP server, the camera will get its IP address, gateway and routing information automatically and you will be able to browse to it.

In the absence of a DHCP server, the camera's default IP address is 169.254.1.1 and its subnet mask is 255.255.0.0. You can configure the camera's static IP address either through the network or from a computer connected directly to its Ethernet port. You may need a crossover cable.

Compatible Web Browsers

Supported web browsers:

- Chrome® (latest version),
- Firefox® (latest version),
- Internet Explorer® (versions 8 through 11)
- Safari® (versions 6 and 7)

Other browsers may also work, but have not been used in testing the product.

User Access

If the admin sets up automatic guest access, no login is needed – the system starts at the Camera Control page, rather than the login page. The administrative login dialog is accessible from the Camera Control page, to allow access to administrative tasks.



Administrative access

When you log in as Admin, all the admin menu buttons appear on the left side of the screen. In addition to Camera Controls, you also have access to:

- Camera Settings – Additional control over camera behavior related to camera movement and color management.
- Room Labels – Information to display on the web interface screens, including the conference room name and phone number and the in-house number for AV assistance.
- Networking – Ethernet configuration.
- Security – Set passwords and manage guest access.
- Diagnostics – View or download logs when troubleshooting issues.
- System – View firmware version and switch settings, reboot, restore factory defaults, and run firmware updates.
- Help – Tech support contact information and a link to the product information library on the Vaddio website.
- Logout – Yes, it's for logging out.

If you are on the Camera Control screen and no other screens are available, you're logged in at the user level, or guest access is enabled and you're not logged on at all. Use the Admin button to open the login screen.

Web Interface Cheat Sheet

Where to find the controls you need right now.

What do you need?	Go to this screen
Camera operation <ul style="list-style-type: none"> ■ Move or zoom the camera ■ Set the speed for pan, tilt, or zoom motions ■ Focus the camera (Focus button reveals the focus control) ■ Move to a camera preset ■ Put the camera into or bring it out of standby mode 	Camera Controls
Camera behavior <ul style="list-style-type: none"> ■ Set inverted operation (Settings button reveals the control) ■ Set or clear camera presets ■ Select the appropriate lighting adjustments (CCU Scenes section) 	Camera Controls
Camera behavior <ul style="list-style-type: none"> ■ What happens on power-up or coming out of standby mode - move to a specified preset, apply specified lighting adjustments ■ Specify whether to use automated adjustments (auto-iris, auto white balance, backlight compensation) 	Camera Settings
Camera adjustments <ul style="list-style-type: none"> ■ Color settings (Iris, iris gain, red gain, blue gain, detail, chroma, gamma) ■ Store and label custom color settings as CCU scenes ■ Specify global speed settings for camera movements that do not use Tri-Synchronous Motion 	Camera Settings
IP streaming settings - quality, resolution, frame rate, streaming URL and path	Streaming
Other IP settings - hostname, DHCP or static addressing, IP address, subnet mask, gateway	Networking
Access management <ul style="list-style-type: none"> ■ Guest access ■ Account passwords 	Security
Diagnostic logs	Diagnostics
Information about the camera location	Room Labels
Helpdesk phone number for end users	Room Labels
Vaddio Technical Support contact information	Help

Web Tasks for All Users: Camera Control

The Camera Control page provides most of the same controls as the IR Remote Commander, along with some that are not available from the remote:

- Put the camera in standby or bring it back to the ready state
- Pan, tilt, zoom, or return to "home" position"
- Set speeds for camera movements
- Focus manually or select auto-focus
- Set the camera for normal or inverted operation
- Set or move to camera presets
- Select one of the stored lighting adjustments

Since the web interface is specific to the camera you are working with, it does not offer camera selection.



Manage camera ready state

Use the Standby button to switch between low-power (standby) and ready states.

In standby mode, the button is red and the screen presents the message "Device is in standby." On entering standby mode, the camera pans 90° from center and 30° downward. Ceiling-mounted cameras also point downward in standby mode; this keeps dust from collecting on the lens.

Move the camera

Use the arrow buttons for camera pan and tilt. The center button moves the camera to the home position.

Zoom in or out

Use the Zoom + button to zoom in and the Zoom - button to zoom out.

Change the speed of camera movements

Use the speed sliders to adjust the speed of movements that you control with the buttons for pan, tilt and zoom. For tight shots, slower is usually better.

Change the focus

Open the Focus control to select Auto-focus or set manual focus with the + (near) and - (far) buttons. You probably get this, but I'm going to say it anyway: The + and - buttons don't work when the Auto Focus box is checked.



Move the camera to a preset position

Use the numbered Preset buttons to move the camera to any of its programmed positions. If you select a preset that has not yet been programmed, nothing happens.

Store a camera preset

Note

Save Preset 1 first. Other presets will inherit its Tri-Sync settings if they have not yet been defined.

1. Set up the camera shot, then use the Store button to open the Store Preset box.
2. Click one of the numbered preset buttons.
3. Check Save with Tri-Sync to allow the pan, tilt, and zoom motors to move simultaneously.
4. If necessary, use the speed slider to set Tri-Sync speed. For tight shots, slower is better.
5. To save the current color settings along with the camera position, check Save with current color settings.
6. Save the preset.

Note

Remember to save the changes you make. Changes to presets are not automatically saved.

Note:

The Tri-Synchronous Motion algorithm works best for on-air shots requiring significant movement. It is not useful when moving the camera less than 10° or when the camera is not on the air. You may need to experiment with Tri-Synchronous Motion speed to find the right setting.



Select the appropriate color settings

Adjust the camera for the lighting in use by selecting the CCU scene that best fits your environment. The technical folks at Vaddio (Scott, to be specific) have already set up presets for common lighting scenarios – Incandescent Hi, Incandescent Lo, Fluorescent Hi, Fluorescent Lo and Outdoor. The Auto setting allows the camera to determine the appropriate adjustments.

The first three settings in this area of the web interface (initially labeled Custom A through Custom C) can be set and renamed from the Camera Settings page, accessible to admin users.

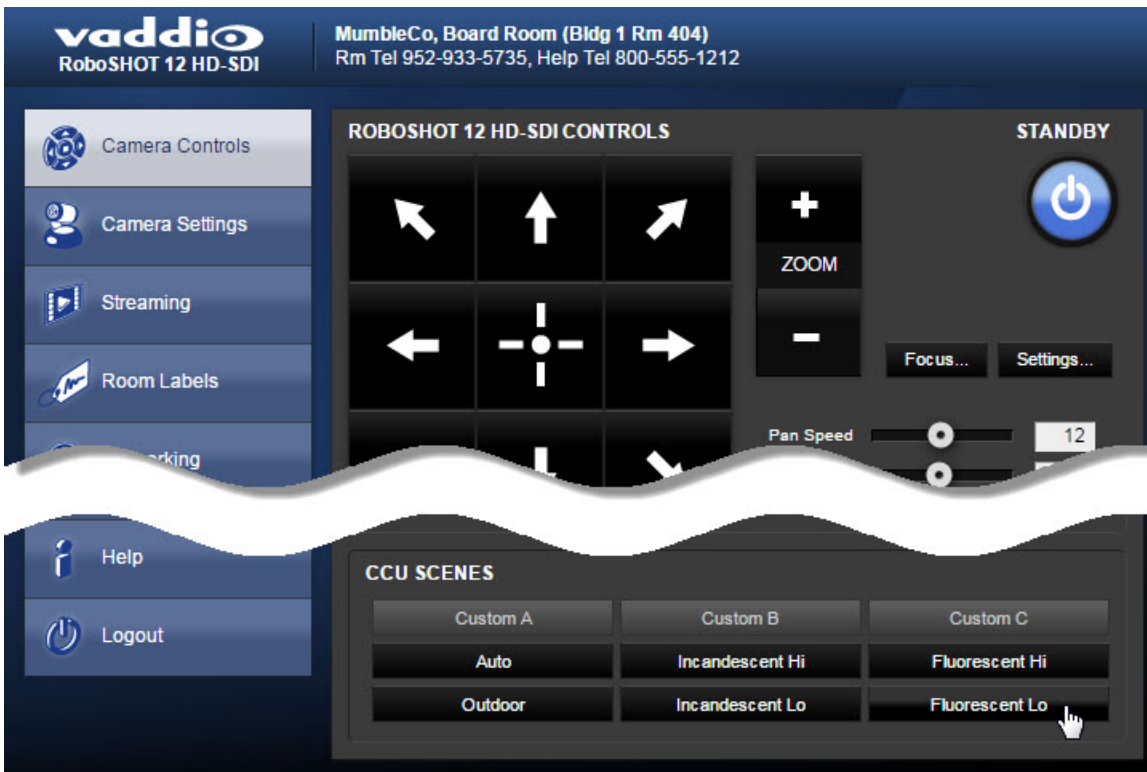

Web Tasks for Administrators: Configuring Network Settings

Things you can do on this screen:

- Assign the camera's hostname
- Specify DHCP or static IP address
- Set up other networking information

You will only be able to enter the IP address, subnet mask, and gateway if you set IP Address to Static.

Note

DHCP is the default setting, but the camera will use the default address of 169.254.1.1 if it can't find a DHCP server.

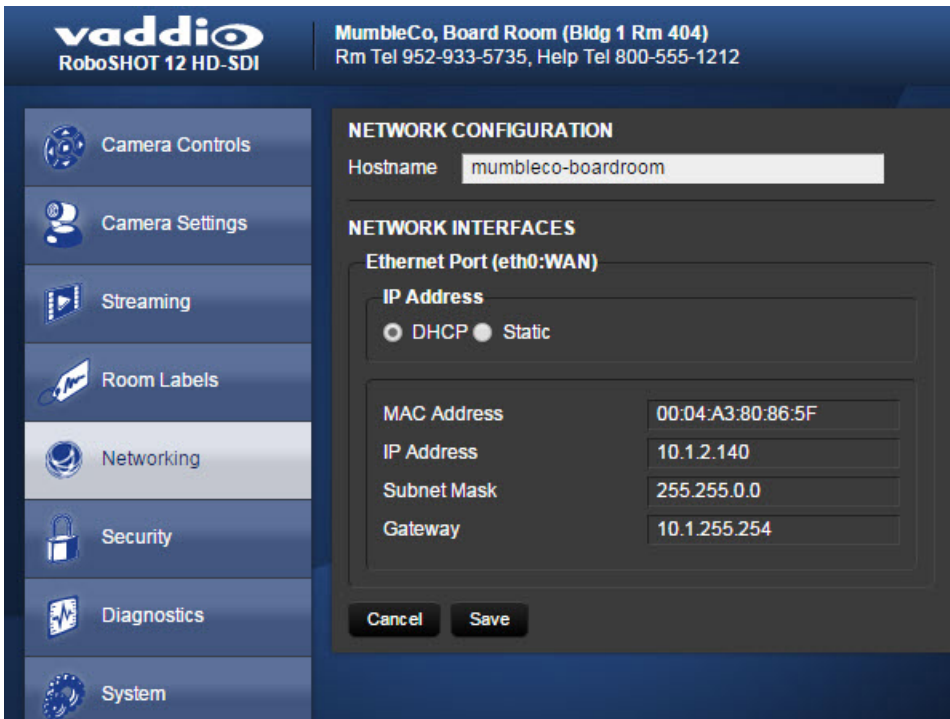

Web Tasks for Administrators: Adding Room Information to the Screen

To display your company name, conference room name and phone number, and the number for meeting hosts to call for in-house A/V support, enter this information on the Room Labels screen.



Web Tasks for Administrators: Managing Access and Passwords

Things you can do on this screen:

- Allow people to access the Camera Control screen without logging on (Allow Guest Access)
- Change the password for the admin account (default is `password`)
- Change the password for the user account (default is `password`)



Web Tasks for Administrators: Setting Camera Behaviors and Adjustments

Things you can do on this screen:

- Set up the shot and color settings the camera uses on power-up or on returning to full power from standby mode.
- Set up and name custom color/lighting settings.
- Set the pan, tilt, and zoom speeds that will be used when not using Tri-Synchronous Motion

The screenshot shows the Vaddio web interface for a RoboSHOT 12 HD-SDI camera. The interface is divided into a left sidebar with navigation icons and a main content area. The main content area is titled 'GLOBAL CAMERA SETTINGS' and includes several sections:

- GLOBAL CAMERA SETTINGS:** Contains two checkboxes: 'Load Preset at Startup' (unchecked) and 'Load CCU Scene at Startup' (unchecked). There are two dropdown menus: 'Preset 1' and 'Auto'.
- CCU SCENES:** A table with three columns: Custom A, Custom B, and Custom C. The rows are: Auto, Incandescent Hi, Fluorescent Hi, Outdoor, Incandescent Lo, and Fluorescent Lo.
- COLOR SETTINGS:** Contains several sliders and input fields:
 - Auto Iris:** Checked. Iris slider is set to F1.8.
 - Gain:** Slider is set to 2.
 - Auto White Balance:** Checked. Red Gain is 200, Blue Gain is 196.
 - Detail (Sharpness):** Slider is set to 8.
 - Chroma (Saturation):** Slider is set to 2.
 - Gamma:** Slider is set to -1.
- CUSTOM CCU SCENE LABELS:** Three input fields for Custom A, Custom B, and Custom C.
- GLOBAL PRESET NON-TRI-SYNC SPEEDS:** Three sliders: Global Pan Speed (20), Global Tilt Speed (17), and Global Zoom Speed (7).

Set up what the camera does on power-up or return from standby

To use a preset position instead of the default home position when the camera wakes up, check Load Preset at Startup. Then select the preset to use.

To specify the color and lighting settings, check Load CCU Scene at Startup, and select the CCU scene to use.

Set up custom color and lighting settings

1. Click any of the CCU scene buttons to load one of the CCU scenes into the camera, then fine-tune it as needed using the Color Settings controls.
2. Auto Iris – check this box to allow the camera to automatically compensate for the light level, or leave it unchecked and use the Iris and Gain sliders to make the desired adjustments.
3. Auto White Balance – check this box to allow the camera to adjust the white balance automatically, or leave it unchecked and use the Red Gain and Blue Gain sliders to make the desired color adjustments.
4. Back Light Compensation (only available in Auto White Balance mode) – check this box if the scene will have bright lighting behind the main subject of the shot.
5. Detail – adjust the slider as required for amount of detail (Aperture) desired.

Note:

If the video looks grainy or “noisy,” try a lower Detail setting. As in conversation, too much detail is bad.

6. Chroma – adjust the slider as needed for the right level of color intensity.
7. When the scene looks the way you want it to, click Store CCU Scene.
8. In the Store CCU Scene dialog box, select which custom scene to store (Custom A, B, or C) and optionally give it a descriptive name. You can rename it later if necessary.
9. Name and save your custom scene.

Note:

Don't worry if you make a change that you don't like. To start over, select Auto White Balance, and then deselect it again.

Rename a custom CCU scene

In the Custom CCU Scene Labels section, edit the text for the desired CCU scene label.

Set pan, tilt, and zoom speeds

In the Global Preset Non-Tri-Sync Speeds section, set the speeds for movements to presets that do not use Tri-Synchronous Motion.

Web Tasks for Administrators: Configuring Streaming Settings

Things you can do on this screen:

- Enable or disable web streaming
- Set the resolution, video quality, and frame rate
- Specify the streaming port and path/URL

The camera uses the RTSP protocol for H.264 streaming. Available resolutions and frame rates are:

Resolution	Frame Rate	Aspect Ratio
1080p	30/25/15	16:9
720p	60/30/25/15	16:9
704 x 576	60/30/25/15	4CIF (~5:4)
720 x 480p	60/30/25/15	3:2
640 x 480p	60/30/25/15	4:3
360p (640 x 360)	60/30/25/15	16:9
352 x 288p	60/30/25/15	CIF (~5:4)

vaddio
RoboSHOT 12 HD-SDI

MumbleCo, Board Room (Bldg 1 Rm 404)
Rm Tel 952-933-5735, Help Tel 800-555-1212

IP STREAMING

GENERAL

Enable IP Streaming Enabled

VIDEO SETTINGS

Quality Mode Easy Custom

Resolution

Video Quality

PROTOCOL

RTSP RTSP Port

STREAMING URL

Path

URL

Cancel Save

To set streaming quality, resolution, and frame rate:

Select the video Quality Mode: Easy or Custom. Easy automatically sets the recommended frame rate; Custom provides additional control.

You will only be able to specify the frame rate if you select Custom Quality Mode.

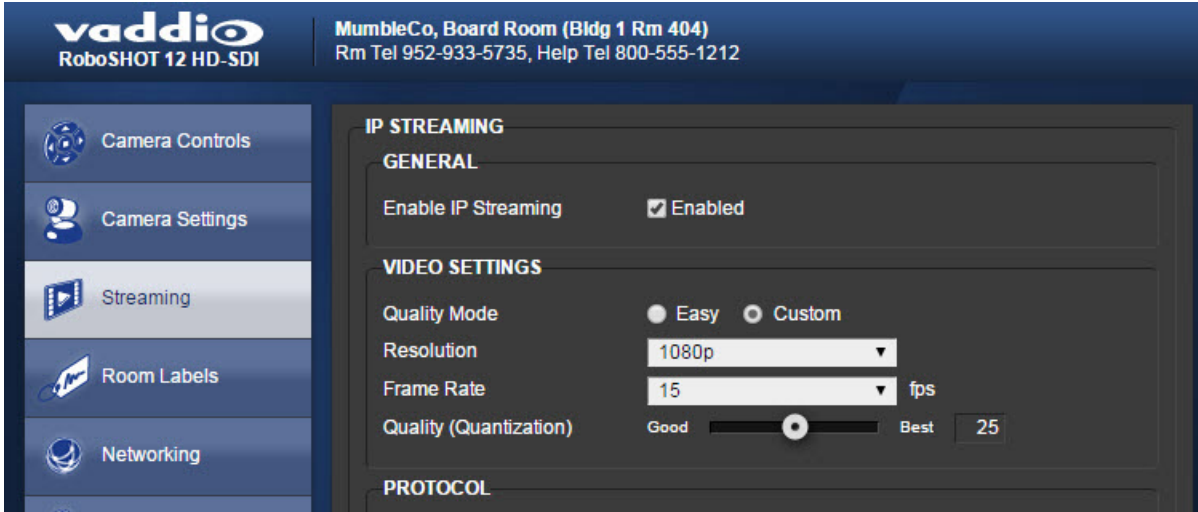

Web Tasks for Administrators: System Reboots, Resets, and Updates

Things you can do on this screen:

- Run a firmware update
- Reboot the camera
- Set the camera back to its original factory settings
- Read (but not change) the current settings of the switches on the back of the camera

Note:

Sorry, you have to physically move the switches on the back of the camera if you need to change the hardware settings.

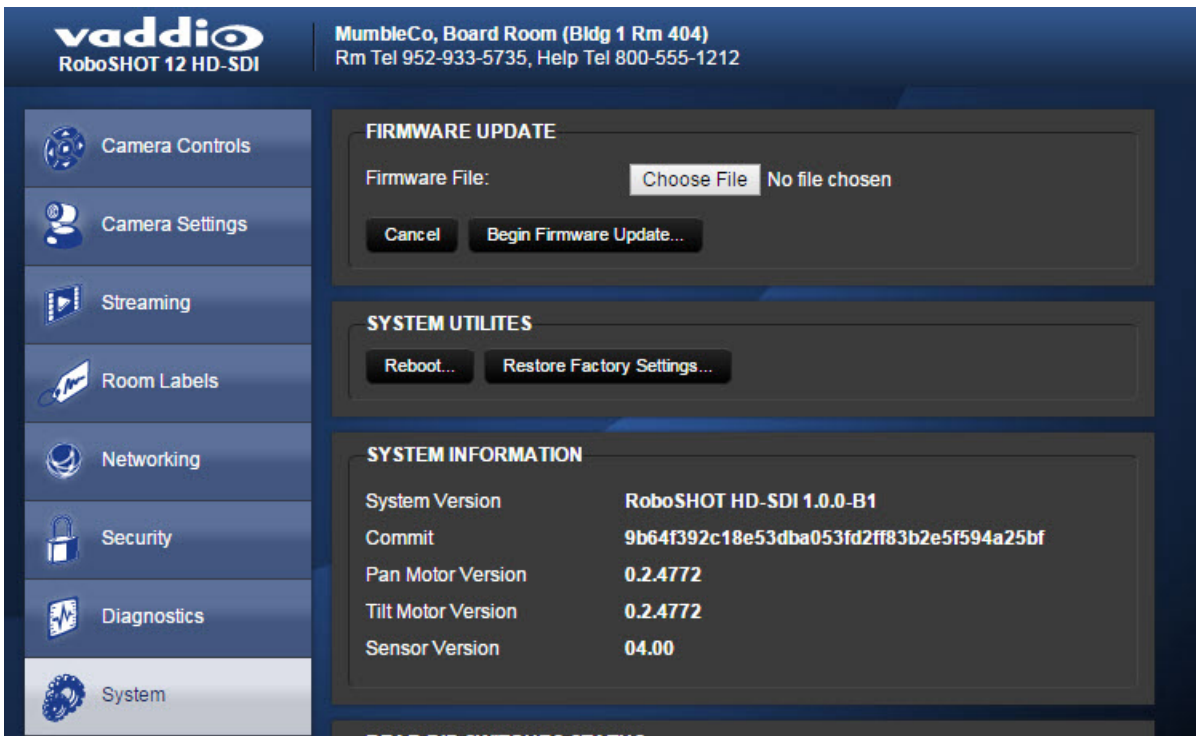

Reboot the camera

This can help if the camera stops responding as you expect. In the System Utilities section, click Reboot.

Restore factory settings

Sometimes it's easiest to just start over. To restore the original factory settings...click Restore Factory Settings. This will overwrite anything you have customized, such as custom camera presets or CCU scenes.

Start a firmware update

1. Be sure you have downloaded the appropriate update file to your computer.
2. Click Choose File and select the camera update file.
3. Click Begin Firmware Update.
4. READ the information in the Confirm dialog box and be sure you understand it. This stuff may seem boring, but it could save you a lot of time and aggravation.
5. When you are ready to start the update, click Continue. A progress message box opens and the indicator light on the front of the camera turns yellow to show the firmware update is in progress.
6. If the update process presents warnings or error messages, read them carefully.
7. Contact Vaddio technical support if you encounter any problems with the update.

Caution

Do not remove power or reset the camera while the indicator is yellow, showing a firmware update in progress. Interrupting a firmware update can make the camera unusable.

Web Tasks for Administrators: Viewing Diagnostic Logs

If you encounter a problem that you can't solve, it may be a bug. Your Vaddio technical support representative may ask you to download and email the log file available from the Diagnostics screen.

The screenshot shows the Vaddio web interface for a RoboSHOT 12 HD-SDI camera. The top navigation bar includes the Vaddio logo, the camera model name, and the location: "MumbleCo, Board Room (Bldg 1 Rm 404)". A "Logout" button is in the top right corner. A left sidebar contains menu items: Camera Controls, Camera Settings, Streaming, Room Labels, Networking, Security, Diagnostics (highlighted), System, Help, and Logout. The main content area is titled "DIAGNOSTICS" and displays a scrollable log of system events. Below the log are four buttons: Download, Refresh, Clear, and Restore.

```

Sep 18 12:19:01 vaddio-risa [ 0.745152] azte_h264s 60000000.h264_axis_core: h264: added driver successfully
Sep 18 12:19:01 vaddio-risa [ 0.753437] sdhci: Secure Digital Host Controller Interface driver
Sep 18 12:19:01 vaddio-risa [ 0.759599] sdhci: Copyright(c) Pierre Ossman
Sep 18 12:19:01 vaddio-risa [ 0.763874] sdhci-pltfm: SDHCI platform and OF driver helper
Sep 18 12:19:01 vaddio-risa [ 0.769765] mmc0: no vqmmc regulator found
Sep 18 12:19:01 vaddio-risa [ 0.773781] mmc0: no vmmc regulator found
Sep 18 12:19:01 vaddio-risa [ 0.814236] mmc0: SDHCI controller on e0100000.ps7-sdio [e0100000.ps7-sdio] using ADMA
Sep 18 12:19:01 vaddio-risa [ 0.833049] ledtrig-cpu: registered to indicate activity on CPUs
Sep 18 12:19:01 vaddio-risa [ 0.843562] nf_contrack version 0.5.0 (6014 buckets, 24056 max)
Sep 18 12:19:01 vaddio-risa [ 0.852095] ip_tables: (C) 2000-2006 Netfilter Core Team
Sep 18 12:19:01 vaddio-risa [ 0.858528] TCP: cubic registered
Sep 18 12:19:01 vaddio-risa [ 0.863791] Initializing XFRM netlink socket
Sep 18 12:19:01 vaddio-risa [ 0.868061] NET: Registered protocol family 17
Sep 18 12:19:01 vaddio-risa [ 0.872460] 8021q: 802.1Q VLAN Support v1.8
Sep 18 12:19:01 vaddio-risa [ 0.876743] Registering SWP/SWPB emulation handler
Sep 18 12:19:01 vaddio-risa [ 0.882206] regulator-dummy: disabling
Sep 18 12:19:01 vaddio-risa [ 0.890686] Waiting for root device /dev/mmcblk0p3...
Sep 18 12:19:01 vaddio-risa [ 0.905371] mmc0: new high speed SD card at address b368
Sep 18 12:19:01 vaddio-risa [ 0.911155] mmcblk0: mmc0:b368 AF UD 471 MiB
Sep 18 12:19:01 vaddio-risa [ 0.919580] mmcblk0: p1 p2 p3 p4 < p5 p6 p7 p8 >
Sep 18 12:19:01 vaddio-risa [ 1.010319] VFS: Mounted root (ext4 filesystem) readonly on device 179:3.
Sep 18 12:19:01 vaddio-risa [ 1.019130] devtmpfs: mounted
Sep 18 12:19:01 vaddio-risa [ 1.022313] Freeing unused kernel memory: 164K (c042c000 - c0455000)
Sep 18 12:19:01 vaddio-risa [ 1.850807] lirc_gpio: module is from the staging directory, the quality is unknown, you have been warned.
Sep 18 12:19:01 vaddio-risa [ 1.861910] lirc_gpio lirc_gpio.0: lirc_dev: driver lirc_gpio registered at minor = 0
Sep 18 12:19:01 vaddio-risa [ 1.869739] lirc_gpio: driver registered!
Sep 18 12:19:01 vaddio-risa [ 1.873664] lirc_gpio: using active low receiver on GPIO pin 74
Sep 18 12:19:01 vaddio-risa [ 2.790444] random: dd urandom read with 48 bits of entropy available
Sep 18 12:19:01 vaddio-risa [ 3.056250] EXT4-fs (mmcblk0p8): warning: mounting unchecked fs, running e2fsck is recommended
Sep 18 12:19:03 vaddio-risa [ 6.694941] random: nonblocking pool is initialized
Sep 18 12:19:08 vaddio-risa [ 11.614992] xmacps e000b000.ps7-ethernet: Set clk to 124999998 Hz
Sep 18 12:19:08 vaddio-risa [ 11.621103] xmacps e000b000.ps7-ethernet: link up (1000/FULL)
    
```

Web Tasks for Administrators: Contacting Vaddio Technical Support

You'll find information for contacting Vaddio Technical Support on the Help screen.



The screenshot displays the Vaddio web interface for the RoboSHOT 12 HD-SDI camera. The top header includes the Vaddio logo and the text "RoboSHOT 12 HD-SDI" on the left, and the address "MumbleCo, Board Room (Bldg 1 Rm 404)" and phone numbers "Rm Tel 952-933-5735, Help Tel 800-555-1212" on the right. A vertical sidebar on the left contains menu items: Camera Controls, Camera Settings, Streaming, Room Labels, Networking, Security, and Diagnostics. The main content area features a "TECHNICAL SUPPORT" section with the following text:

You can reach Vaddio technical support by calling:

- Direct:** +1 (763) 971-4428
- Toll Free:** +1 (800) 572-2011
- Fax:** +1 (763) 971-4464

Through email by sending your questions to:

support@vaddio.com

Or access support information directly on our web page at:

<http://help.vaddio.com/roboshot-12-hd-sdi>

Telnet Serial Command API

The Vaddio serial command protocol is a high-level, text-based command line interface supported via Telnet session on the camera. The API is accessed by a telnet client on the Ethernet port; the default Telnet port is 23. Telnet sessions require the administrator account login.

The command application protocol interface is intended to allow external device such as AMX or Crestron to control the camera. The protocol is based upon ASCII format following the VT100 terminal emulation standard and uses an intuitive text command nomenclature for ease of use.

General format usage follows a get/set structure.

Usage examples for each type are:

Set Example

COMMAND: > camera pan right

RESPONSE: > OK

Get Example

COMMAND: > camera home get

RESPONSE: > OK

Syntax Error Example

COMMAND: > camera right pan

RESPONSE: > ERROR

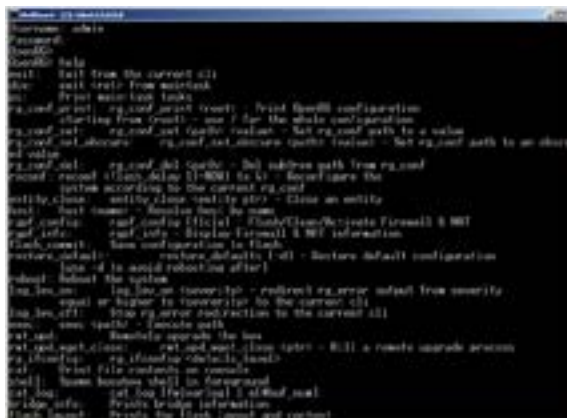

Things to know about control via Telnet session:

- All ASCII characters will be echoed to terminal program and appended with VT100 string -ESC[J (HEX-1B 5B 4A).
- Command lines are terminated with a carriage return. After the carriage return, the VT100 appends with -ESC[J.
- Most terminal programs automatically strip the VT100 string.
- [CTRL] 5 Clears the current serial buffer on the device.

RoboSHOT HD-SDI cameras support the Telnet commands in the following sections.

camera home

Moves the camera to its home position.

Synopsis	camera home
Example	camera home

Touchboards
 205 Westwood Ave, Long Branch, NJ 07740
 Phone: 866-94 BOARDS (26273) / (732)-222-1511
 Fax: (732)-222-7088 | E-mail: sales@touchboards.com

camera pan

Moves the camera horizontally

Synopsis	<code>camera pan { left [<speed>] right [<speed>] stop }</code>	
Options	<code>left</code>	Moves the camera left
	<code>right</code>	Moves the camera right
	<code>speed [1 - 24]</code>	Optional - integer 1 - 24 specifies the speed for the commanded movement Default speed is 12
	<code>stop</code>	Stops the camera's horizontal movement
Examples	<code>camera pan left</code> Pans the camera left at the default speed	
	<code>camera pan right 20</code> Pans the camera right using a speed of 20	
	<code>camera pan stop</code> Stops the camera's horizontal motion	

camera tilt

Moves the camera vertically.

Synopsis	<code>camera tilt{ up [<speed>] down [<speed>] stop }</code>	
Options	<code>up</code>	Moves the camera up
	<code>down</code>	Moves the camera down
	<code>speed [1 - 20]</code>	Optional - integer 1 - 20 specifies the speed for the commanded movement Default speed is 10
	<code>stop</code>	Stops the camera's vertical movement
Examples	<code>camera tilt up</code> Tilts the camera up at the default speed	
	<code>camera tilt down 20</code> Tilts the camera down using a speed of 20	
	<code>camera tilt stop</code> Stops the camera's vertical motion	

camera zoom

Moves the camera in toward the subject or out away from the subject.

Synopsis	camera zoom { in [<speed>] out [<speed>] stop }	
Options	in	Moves the camera in
	out	Moves the camera out
	speed[1 - 7]	Optional - integer 1 - 7 specifies the speed for the commanded movement Default speed is 3
	stop	Stops the camera's zoom movement
Examples	camera zoom in Zooms the camera in at the default speed	
	camera zoom out 7 Zooms the camera out using a speed of 7	
	camera zoom stop Stops the camera's zoom motion	

camera focus

Changes the camera focus.

Synopsis	<code>camera focus {{ near [<speed>] far [<speed>]] {mode [auto manual]} stop }</code>	
Options	<code>near</code>	Brings the focus nearer to the camera Can only be used when camera is in manual mode
	<code>far</code>	Moves the focus farther from the camera Can only be used when camera is in manual mode.
	<code>speed [1 - 8]</code>	Optional - integer 1 - 8 specifies the speed for the commanded movement
	<code>mode [auto manual]</code>	Specifies automatic or manual focus
	<code>stop</code>	Stops the camera's focus movement
Examples	camera focus near Brings the focus near at the default speed	
	camera focus far 7 Moves the focus farther from the camera at a speed of 7	
	camera focus mode auto Sets the camera in auto-focus mode	
	camera focus stop Stops the camera's focus motion	
		

camera preset

Moves the camera to the specified preset, or stores the current camera position and optionally CCU information, either with or without specifying that Tri-Synchronous Motion is to be used when moving to this position.

Synopsis	<code>camera preset { recall store} [1 - 16] [tri-sync <1 - 24>] [save-ccu]</code>	
Options	<code>recall [1 - 16]</code>	Moves the camera to the specified preset, using Tri-Synchronous Motion if this was saved with the preset. If CCU information was saved with the preset, the camera switches to the CCU setting associated with the preset.
	<code>store [1 - 16]</code>	Stores the current camera position as the specified preset.
	<code>tri-sync [1 - 24]</code>	Optional - specifies that the camera uses Tri-Synchronous Motion to move to this position, using the specified speed.
	<code>save-ccu</code>	Optional - Saves the current CCU settings as part of the preset. If not specified, the last color settings are used when recalled.
Examples	<code>camera preset recall 3</code> Moves the camera to preset 3.	
	<code>camera preset store 1</code> Saves the camera's current position as preset 1.	
	<code>camera preset store 4 tri-sync 15</code> Stores the camera's current position as preset 4. The camera will use Tri-Synchronous Motion at speed 15 when it is recalled to this preset.	
	<code>camera preset store 2 tri-sync 10 save-ccu</code> Stores the camera's current position as preset 2. The camera apply the current CCU settings and use Tri-Synchronous Motion at speed 15 when it is recalled to this preset.	

camera ccu get

Returns or sets CCU (lighting) information.

Synopsis	<code>camera ccu get [param]</code>	
Options 	<code>auto_white_balance</code>	Returns the current state of the auto white balance setting (on or off).
	<code>red_gain</code>	Returns the red gain value as an integer between 0 and 255.
	<code>blue_gain</code>	Returns the blue gain value as an integer between 0 and 255.
	<code>backlight_compensation</code>	Returns the current state of the backlight compensation setting (on or off).
	<code>iris</code>	Returns the iris value as an integer between 0 and 13.
	<code>auto_iris</code>	Returns the current auto-iris state (on or off).
	<code>gain</code>	Returns the gain value as an integer between 0 and 13.
	<code>detail</code>	Returns the detail value as an integer between 0 and 15.
	<code>chroma</code>	Returns the chroma value as an integer between 0 and 14.
	<code>all</code>	Returns all current CCU settings.
Examples	<pre>camera ccu get iris iris 11 Returns the current iris value.</pre>	
	<pre>camera ccu get red_gain red_gain 201 Returns the current red gain value.</pre>	
	<pre>camera ccu get all auto_iris on auto_white_balance on backlight_compensation off blue_gain 193 chroma 2 detail 8 gain 3 iris 11 red_gain 201 Returns all current CCU settings.</pre>	

camera ccu set

Sets the specified CCU (lighting) information.

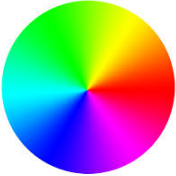
Synopsis	camera ccu set [param] [value]	
Options 	auto_white_balance [on off]	Sets the current state of the auto white balance setting (on or off). Auto white balance overrides red gain and blue gain manual settings.
	red_gain [0 - 255]	Sets the red gain value. Valid range: integers 0 to 255. Can only be used when auto white balance is off.
	blue_gain [0 - 255]	Sets the blue gain value. Valid range: integers 0 to 255. Can only be used when auto white balance is off.
	backlight_compensation [on off]	Sets the current state of the backlight compensation setting (on or off).
	iris [0 - 13]	Sets the iris value. Valid range: integers between 0 and 13. Can only be used when auto-iris is off.
	auto_iris [on off]	Sets the auto-iris state (on or off). Auto-iris disables manual iris and gain when it is on.
	gain [0 - 13]	Sets gain value. Valid range: integers 0 to 13. Can only be used when auto-iris is off.
	detail [0 - 15]	Sets the detail value. Valid range: integers 0 to 15.
	chroma [0 - 14]	Sets the chroma value. Valid range: integers 0 to 14.
Examples	camera ccu set auto_iris off Turns off auto-iris mode, returning the camera to manual iris control.	
	camera ccu set red_gain 10 Sets the red gain value to 10.	

camera ccu scene

Stores the current CCU scene or recalls the specified ccu scene.

Synopsis	camera ccu scene {recall {factory [1 - 6] custom [1 - 3]} store custom [1 - 3]}	
Options	recall factory [1 - 6]	Recalls the camera to the specified scene (factory 1 - 6 or custom 1 - 3) .
	recall custom [1 - 3]	
	store custom [1 - 3]	Saves the current scene as the specified custom scene.
Examples	camera ccu scene recall factory 2 Sets the camera to use factory CCU scene 2.	
	camera ccu scene store custom 1 Saves the current CCU scene as custom CCU scene 1.	

camera standby

Set or change camera standby status.

Synopsis	camera standby { off on toggle}	
Options	off	Brings the camera out of standby (sleep) mode.
	on	Stops video and puts the camera in standby mode.
	toggle	Changes the camera's standby state - if it was not in standby mode, it enters standby; if it was in standby mode, it "wakes up."
Examples	camera standby off Brings the camera out of standby mode.	
	camera standby on Puts the camera in standby mode.	

streaming settings

Retrieves or specifies IP streaming settings.

Synopsis	<code>streaming settings {get set [ip_enabled] [ip_port] [ip_protocol] [ip_quality] [ip_resolution] [ip_url]}</code>	
Options	<code>ip_enabled [true false]</code>	<code>true</code> enables streaming; <code>false</code> disables it.
	<code>ip_port <port number></code>	Specifies the port that the IP stream uses. Port 554 is typical.
	<code>ip_protocol [rtsp]</code>	Specifies the streaming protocol. Only RTSP is supported at this time.
	<code>ip_quality [low standard high]</code>	Specifies the video quality. Low is useful for low-bandwidth situations.
	<code>ip_resolution <value></code> Valid resolutions: 1080p 720p 4cif 480p 640x480 360p cif	Specifies streaming video resolution.
	<code>ip_url <URL></code>	Specifies the URL where the stream is available.
Examples	<p>streaming settings get</p> <p>Returns the current streaming settings in a form something like this:</p> <pre>IP Enabled true IP Port 554 IP Protocol RTSP IP Quality High Quality (Best) IP Resolution 720p IP Url Lobby-conference</pre>	

network ping

Sends an ICMP ECHO_REQUEST to the specified IP address.

Synopsis	<code>network ping [count <count>] [size <size>] <destination-ip></code>	
Options	<code>count</code>	The number of ECHO_REQUEST packets to send. If this is not specified, the default is five packets.
	<code>size</code>	The size of each ECHO_REQUEST packet. If this is not specified, the default is 56 bytes.
	<code><destination-ip></code>	The IP address where the ECHO_REQUEST packets will be sent.
Examples	<code>network ping 192.168.1.1</code> Sends five ECHO_REQUEST packets of 56 bytes each to the host at 192.168.1.1.	
	<code>network ping count 10 size 100 192.168.1.1</code> Sends 10 ECHO_REQUEST packets of 100 bytes each to the host at 192.168.1.1.	

network settings get

Returns the current network settings for mac address, ip address, netmask, and gateway

Synopsis	<code>network settings get</code>	
Example	<code>network settings get</code> <pre>MAC Address: 00:04:a3:85:0a:ee IP Address: 10.10.8.116 Netmask: 255.255.255.0 Gateway: 10.10.8.100</pre>	

system reboot

Reboots the system either immediately or after the specified delay. Note that a reboot is required when resetting the system to factory defaults (`system factory-reset`).

Synopsis	<code>system reboot [<seconds>]</code>	
Options	<code><seconds></code>	The number of seconds to delay the reboot
Examples	<code>system reboot</code> Reboots the system immediately.	
	<code>system reboot 30</code> Reboots the system in 30 seconds.	

system factory-reset

Gets or sets the factory reset status. When the factory reset status is on, the system resets to factory defaults on reboot.

Synopsis	<code>system factory-reset{ get on off}</code>	
Options	<code>get</code>	Returns the camera's current factory reset status.
	<code>on</code>	Enables factory reset on reboot.
	<code>off</code>	Disables factory reset on reboot.
Examples 	<p>system factory-reset get</p> <p>Returns the factory reset status in this form:</p> <pre>factory-reset (software) : off</pre> <p>(This evaluates the most recent <code>system factory-reset on</code> or <code>off</code> command, if one has been received.)</p> <pre>factory-reset (hardware) : off</pre> <p>(This reads the rear panel DIP switches and returns the status <code>on</code> if they are all in the down position.)</p>	
	<p>system factory-reset on</p> <p>Enables factory reset upon reboot. Returns current status in this form:</p> <pre>factory-reset (software) : on</pre> <pre>factory-reset (hardware) : off</pre>	

history

Returns the most recently issued commands from the current Telnet session. Since many of the programs read user input a line at a time, the command history is used to keep track of these lines and recall historic information.

Synopsis	history <limit>	
Options	<limit>	Integer value specifying the maximum number of commands to return.
Examples	history Displays the current command buffer.	
	history 5 Sets the history command buffer to remember the last 5 unique entries.	
Additional information	<p>You can navigate the command history using the up and down arrow keys.</p> <p>This command supports the expansion functionality from which previous commands can be recalled from within a single session. History expansion is performed immediately after a complete line is read.</p> <p>Examples of history expansion:</p> <ul style="list-style-type: none"> * !! Substitute the last command line. * !4 Substitute the 4th command line (absolute as per 'history' command) * !-3 Substitute the command line entered 3 lines before (relative) 	

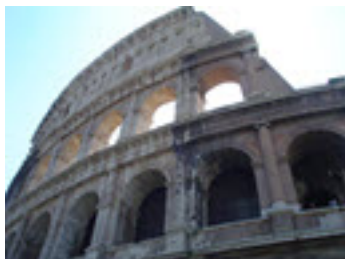

version

Returns the current firmware version.

Synopsis	version
Example	<p>version</p> <p>Returns current firmware version information in a form something like this:</p> <pre>System version: RoboSHOT HD-SDI 1.0.0 Commit: d033ddb2378357a871011eb820706dcaa64ec0e2 Pan Motor Version: 0.2.4586 Tilt Motor Version: 0.2.4586 Sensor Version: 02.00</pre>

help

Displays an overview of the CLI syntax.

Synopsis	help
Example	help



exit

Ends the command session and then does one of these two things:

- Telnet: Closes the socket.
- RS-232 serial: Automatically starts a new session.

Synopsis	exit
Example	exit

RS-232 Serial Communication

The RS-232 serial port (color-coded blue) near the center of the camera's back panel provides another means of controlling the camera.

Specification	Value
Communication Speed	9600 bps (default)
Number of start bits	1
Number of stop bits	1
Number of data bits	8
Parity	None
Flow control	None

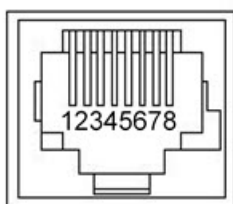

Connector pin-out:

- Pin 1: Not used
- Pin 2: Not used
- Pin 3: Not used
- Pin 4: Not used
- Pin 5: Not used
- Pin 6: GND
- Pin 7: RXD (from TXD of control source)
- Pin 8: TXD (to RXD of control source)

Caution:

Check Cat-5 cables for continuity before using them. Using the wrong pin-out may damage the camera system and void the warranty, which is bad. Pro tip: Label your cables.

The Vaddio RoboSHOT Control Protocol is similar to the Sony® VISCA™ command set in order to be compatible with several popular control devices. Not all VISCA commands are supported and there are many Vaddio-specific commands in the following Command and Inquiry Lists.

RS-232 Command List

Command Set	Command	Command Packet	Comments
AddressSet	Broadcast	88 30 01 FF	Sets address for all daisy-chained cameras
IF_Clear	Broadcast	88 01 00 01 FF	I/F Clear
CommandCancel		8x 2p FF	p= Socket No.(1-2)
CAM_Power	On	8x 01 04 00 02 FF	Power on
	Off	8x 01 04 00 03 FF	Power off

Command Set	Command	Command Packet	Comments
CAM_Zoom	Stop	8x 01 04 07 00 FF	
	Tele(std)	8x 01 04 07 02 FF	
	Wide(std)	8x 01 04 07 03 FF	
	Tele(variable)	8x 01 04 07 2p FF	p= speed 0:low to 7:high
	Wide(variable)	8x 01 04 07 3p FF	p= speed 0:low to 7:high
	Direct	8x 01 04 47 0p 0q 0r 0s FF	pqrs=Zoom Position (0h-4000h)
CAM_Focus	Stop	8x 01 04 08 00 FF	
	Far (std)	8x 01 04 08 02 FF	
	Near (std)	8x 01 04 08 03 FF	
	Far (variable)	8x 01 04 08 2p FF	p= speed 0:low to 7:high
	Near (variable)	8x 01 04 08 3p FF	p= speed 0:low to 7:high
	Direct	8x 01 04 48 0p 0q 0r 0s FF	pqrs=Focus Position (1000h – F000h)
	Auto Focus	8x 01 04 38 02 FF	
	Manual Focus	8x 01 04 38 03 FF	
	Auto/Manual	8x 01 04 08 10 FF	
	One Push Trigger	8x 01 04 18 01 FF	One push AF Trigger
	Near Limit	8x 01 04 28 0p 0q 0r 0s FF	pqrs=Near focus Limit***
CAM_AFSensitivity	Normal	8x 01 04 58 02 FF	AF Sensitivity High / Low
	Low	8x 01 04 58 03 FF	
CAM_AFMode	Normal AF	8x 01 04 57 00 FF	AF movement mode
	Internal AF	8x 01 04 57 01 FF	
	Zoom Trigger AF	8x 01 04 57 02 FF	
	Activate/Internal Time	8x 01 04 27 0p 0q 0r 0s FF	pqrs=movement time, rs=Interval
CAM_IRCorrection	Standard	8x 01 04 11 00 FF	Focus IR compensation data switching
	IR light	8x 01 04 11 01 FF	
CAM_ZoomFocus	Direct	8x 01 04 47 0p 0q 0r 0s 0t 0u 0v 0w FF	pqrs=Zoom Position (0h – 4000h) RoboSHOT 12 (0h - 7AC0h) RoboSHOT 30 tuvw=Focus Position (1000h – F000h)

Command Set	Command	Command Packet	Comments
CAM_WB	Auto	8x 01 04 35 00 FF	Normal Auto
	Indoor	8x 01 04 35 01 FF	Indoor mode
	Outdoor	8x 01 04 35 02 FF	Outdoor mode
	One Push WB	8x 01 04 35 03 FF	One Push WB mode
	ATW	8x 01 04 35 04 FF	Auto Tracing White Balance
	Manual	8x 01 04 35 05 FF	Manual Control mode
	One Push Trigger	8x 01 04 10 05 FF	One Push WB Trigger
	Outdoor Auto	8x 01 04 35 06 FF	Outdoor auto
	Sodium Lamp Auto	8x 01 04 35 07 FF	Auto including sodium lamp source
	Sodium Lamp	8x 01 04 35 08 FF	Sodium lamp source fixed mode
	Sodium Lamp Outdoor Auto	8x 01 04 35 09 FF	Outdoor auto including sodium lamp source
CAM_RGain	Reset	8x 01 04 03 00 FF	Manual control of red gain
	Up	8x 01 04 03 02 FF	
	Down	8x 01 04 03 03 FF	
	Direct	8x 01 04 43 00 00 0p 0q FF	pq=Red gain (00h – FFh)
CAM_BGain	Reset	8x 01 04 04 00 FF	Manual control of blue gain
	Up	8x 01 04 04 02 FF	
	Down	8x 01 04 04 03 FF	
	Direct	8x 01 04 44 00 00 0p 0q FF	pq=Blue gain (00h – FFh)
CAM_AE	Full Auto	8x 01 04 39 00 FF	Auto Exposure mode
	Manual	8x 01 04 39 03 FF	Manual Control mode
	Shutter Priority	8x 01 04 39 0A FF	Shutter Priority Auto Exposure mode
	Iris Priority	8x 01 04 39 0B FF	Iris Priority Auto Exposure Mode
	Bright	8x 01 04 39 0D FF	Bright Mode (modified AE mode)

Command Set	Command	Command Packet	Comments
CAM_ExpComp	On	8x 01 04 3E 02 FF	Exposure Compensation On
	Off	8x 01 04 3E 03 FF	Exposure Compensation Off
	Reset	8x 01 04 0E 00 FF	
	Up	8x 01 04 0E 02 FF	
	Down	8x 01 04 0E 03 FF	
	Direct	8x 01 04 4E 00 00 0p 0q FF	pq=ExpComp Position(0h-0Eh)
CAM_Shutter	Reset	8x 01 04 0A 00 FF	Shutter Setting
	Up	8x 01 04 0A 02 FF	
	Down	8x 01 04 0A 03 FF	
	Direct	8x 01 04 4A 00 00 0p 0q FF	pq=Shutter Position (00h – 15h)
CAM_Iris	Reset	8x 01 04 0B 00 FF	Iris Setting
	Up	8x 01 04 0B 02 FF	
	Down	8x 01 04 0B 03 FF	
	Direct	8x 01 04 4B 00 00 0p 0q FF	pq=Iris Position** RoboSHOT 12 (0h, 07h-11h) RoboSHOT 30 (0h, 05h-11h)
CAM_Gain	Reset	8x 01 04 0C 00 FF	Iris Gain Setting
	Up	8x 01 04 0C 02 FF	
	Down	8x 01 04 0C 03 FF	
	Direct	8x 01 04 4C 00 00 0p 0q FF	pq=Gain Position (01h – 0Fh)
	+Gain Limit	8x 01 04 2C 0p FF	p= Gain limit (04h-0Fh)
CAM_Bright	Reset	8x 01 04 0D 00 FF	Bright Setting
	Up	8x 01 04 0D 02 FF	
	Down	8x 01 04 0D 03 FF	
CAM_BackLight	On	8x 01 04 33 02 FF	Backlight Compensation On/Off
	Off	8x 01 04 33 03 FF	
CAM_Tally	On	8x 01 7E 01 0A 00 02 FF	
	Off	8x 01 7E 01 0A 00 03 FF	

Command Set	Command	Command Packet	Comments
CAM_WD	On	8x 01 04 3D 02 FF	WD On
	Off	8x 01 04 3D 03 FF	WD Off
	VE On	8x 01 04 3D 06 FF	VE On
	Set Parameter	8x 01 04 2D 00 0q 0r 0s 00 00 00 00 FF	q=Display brightness (0 Dark – 6 Bright) r=Brightness compensation (0: Very dark, 1: Dark, 2: std, 3: bright) s=Compensation level (0: Low, 1: Mid, 2: High)
CAM_Aperture	Reset	8x 01 04 02 00 FF	Aperture Setting
	Up	8x 01 04 02 01 FF	
	Down	8x 01 04 02 02 FF	
	Direct	8x 01 04 42 00 00 0p 0q FF	pq=Aperture Position (0h-0fh)
CAM_HR	On	8x 01 04 52 02 FF	High Resolution Mode On/Off
	Off	8x 01 04 52 03 FF	
CAM_NR	--	8x 01 04 53 0p FF	p= Noise Reduction level (0:Off, 1-5)
CAM_Gamma	--	8x 01 04 5B 0p FF	p= Gamma setting (0:std, 1: Straight)
CAM_LR_Reverse	On	8x 01 04 61 02 FF	LR Reverse On/Off (mirror)
	Off	8x 01 04 61 03 FF	
CAM_Freeze	On	8x 01 04 62 02 FF	Freeze On/Off
	Off	8x 01 04 62 03 FF	
CAM_PictureEffect	Off	8x 01 04 63 00 FF	Picture Effect Setting
	Neg.Art	8x 01 04 63 02 FF	
	Black & White	8x 01 04 63 04 FF	
CAM_PictureFlip	On	8x 01 04 66 02 FF	Image-Flip On/Off
	Off	8x 01 04 66 03 FF	
CAM_ICR	On	8x 01 04 01 02 FF	ICR Mode On/Off - adds an IR cut filter to the image for low light images
	Off	8x 01 04 01 03 FF	
CAM_IDWrite		8x 01 04 22 0p 0q 0r 0s FF	pqrs=Camera ID (0h-ffffh)

Command Set	Command	Command Packet	Comments
CAM_Memory	Reset	8x 01 04 3F 00 0p FF	p= preset number(0h-0fh)
	Set standard	8x 01 04 3F 01 0p FF	qr= Speed(01h-18h)
	Set standard with 'scene'	8x 01 04 3F 21 0p FF	
	Set Tri-sync	8x 01 04 3F 11 0p 0q 0r FF	
	Set Tri-Sync with 'scene'	8x 01 04 3F 31 0p 0q 0r FF	
	Recall standard	8x 01 04 3F 02 0p FF	
	Recall Tri-sync	8x 01 04 3F 12 0p FF	
Cam_Display	On	8x 01 04 15 02 FF	Display On/Off
	Off	8x 01 04 15 03 FF	
	On/Off	8x 01 04 15 10 FF	
Cam_Mute	On	8x 01 04 75 02 FF	Mute On/Off
	Off	8x 01 04 75 03 FF	
	On/Off	8x 01 04 75 10 FF	
CAM_ColorEnhance	Parameter Set	8x 01 04 20 mm 00 pp qq rr ss tt uu FF	mm: Threshold level pp: Y fixed color for high-intensity qq: Cr fixed color for high-intensity rr: Cb fixed color for high-intensity ss: Y fixed color for low-intensity tt: Cr fixed color for low-intensity uu: Cb fixed color for low-intensity Each parameter setting 00h to 7Fh
	On	8x 01 04 50 02 FF	Color Enhancement On/Off
	Off	8x 01 04 50 03 FF	
CAM_ChromaSuppress		8x 01 04 5F pp FF	pp: Chroma Suppress level 00: Off 01h to 03h: On (3 levels; larger number = larger effect)

Command Set	Command	Command Packet	Comments
CAM_ColorGain	Direct	8x 01 04 49 00 00 00 0p FF	p: Color Gain Setting 0h to 4h
CAM_ColorHue	Direct	8x 01 04 4F 00 00 00 0p FF	p: Color Hue Setting 0h (-14 degrees) to Eh (+14 degrees)
CAM_GammaOffset	Direct	8x 01 04 1E 00 00 00 0s 0t 0u FF	s: Polarity offset (0 is plus, 1 is minus) tu: Offset s=0 (00h to 40h) Offset s=1 (00h to 10h)
Pan-TiltDrive	Up	8x 01 06 01 vv ww 03 01 FF	vv= Pan speed (01h-18h) ww=Tilt speed (01h-14h)
	Down	8x 01 06 01 vv ww 03 02 FF	
	Left	8x 01 06 01 vv ww 01 03 FF	
	Right	8x 01 06 01 vv ww 02 03 FF	
	UpLeft	8x 01 06 01 vv ww 01 01 FF	
	UpRight	8x 01 06 01 vv ww 02 01 FF	
	DownLeft	8x 01 06 01 vv ww 01 02 FF	
	DownRight	8x 01 06 01 vv ww 02 02 FF	
	Stop	8x 01 06 01 vv ww 03 03 FF	
	Absolute Position	8x 01 06 02 vv ww 0Y 0Y 0Y 0Y 0Z 0Z 0Z 0Z FF	0Y0Y0Y0Y = Pan position (90E2h-6BD8h) 0Z0Z0Z0Z = Tilt position (EB99h-3D59h)
Home	8x 01 06 04 FF	Returns the camera to its default position without changing zoom	
Pan-Tilt-ZoomDrive	Up	8x 01 06 0A vv ww rr 03 01 03 FF	vv= Pan speed (01h-18h) ww=Tilt speed (01h-14h) rr=Zoom speed (00h-07h)
	Down	8x 01 06 0A vv ww rr 03 02 03 FF	
	Left	8x 01 06 0A vv ww rr 01 03 03 FF	
	Right	8x 01 06 0A vv ww rr 02 03 03 FF	
	In	8x 01 06 0A vv ww rr 03 03 01 FF	

Command Set	Command	Command Packet	Comments
	Out	8x 01 06 0A vv ww rr 03 03 02 FF	
	Stop	8x 01 06 0A vv ww rr 03 03 03 FF	
	Absolute Position	8x 01 06 0B vv ww 0Y 0Y 0Y 0Y 0Z 0Z 0Z 0Z 0R 0R 0R 0R FF	vv: Pan speed (01h-18h) ww: Tilt speed (01h-14h) 0Y0Y0Y0Y = Pan position (90E2h-6BD8h) 0Z0Z0Z0Z = Tilt position (EB99h-3D59h) 0R0R0R0R = Zoom position (0000h-4000h) RoboSHOT 12 (0000h-7AC0h) RoboSHOT 30
	Home	8x 01 06 0C FF	Returns the camera to the default position and zoom
CAM_PTZ_PresetSpeed		8x 01 7e 01 0b pp qq rr FF	pp:pan speed (01h-18h), qq:tilt speed (01h-14h), rr:zoom speed (0h-07h) Applies only if Tri-Synchronous Motion is not used.

RS-232 Inquiry Command List

Inquiry Command	Command	Response Packet	Comments
CAM_PowerInq	8x 09 04 00 FF	y0 50 02 FF	On
		y0 50 03 FF	Off (Standby)
CAM_ZoomPosInq	8x 09 04 47 FF	y0 50 0p 0q 0r 0s FF	pqrs: Zoom Position
CAM_FocusModelInq	8x 09 04 38 FF	y0 50 02 FF	Auto Focus
		y0 50 03 FF	Manual Focus
CAM_FocusPosInq	8x 09 04 48 FF	y0 50 0p 0q 0r 0s FF	pqrs: Focus Position
CAM_FocusNearLimitInq	8x 09 04 28 FF	y0 50 0p 0q 0r 0s FF	pqrs: Focus Near Limit Position
CAM_AFSensitivityInq	8x 09 04 58 FF	y0 50 02 FF	AF Sensitivity Normal
		y0 50 03 FF	AF Sensitivity Low
CAM_AFModelInq	8x 09 04 57 FF	y0 50 00 FF	Normal AF
		y0 50 01 FF	Interval AF
		y0 50 02 FF	Zoom Trigger AF
CAM_AFTimeSettingInq	8x 09 04 27 FF	y0 50 0p 0q 0r 0s FF	pq: Movement Time, rs: Interval
CAM_IRCorrectionInq	8x 09 04 11 FF	y0 50 00 FF	Standard
		y0 50 01 FF	IR Light
CAM_WBModelInq	8x 09 04 35 FF	y0 50 00 FF	Auto
		y0 50 01 FF	Indoor
		y0 50 02 FF	Outdoor
		y0 50 03 FF	One Push WB
		y0 50 04 FF	ATW
		y0 50 05 FF	Manual
		y0 50 06 FF	Outdoor Auto
		y0 50 07 FF	Sodium Lamp Auto
		y0 50 08 FF	Sodium Lamp
		y0 50 09 FF	Sodium Lamp Outdoor Auto
CAM_RGainInq	8x 09 04 43 FF	y0 50 00 00 0p 0q FF	pq: R Gain
CAM_BGainInq	8x 09 04 44 FF	y0 50 00 00 0p 0q FF	pq: B Gain

Inquiry Command	Command	Response Packet	Comments
CAM_AEModeInq	8x 09 04 39 FF	y0 50 00 FF	Full Auto
		y0 50 03 FF	Manual
		y0 50 0A FF	Shutter Priority
		y0 50 0B FF	Iris Priority
		y0 50 0D FF	Bright
CAM_ShutterPosInq	8x 09 04 4A FF	y0 50 00 00 0p 0q FF	pq: Shutter Position
CAM_IrisPosInq	8x 09 04 4B FF	y0 50 00 00 0p 0q FF	pq: Iris Position
CAM_GainPosInq	8x 09 04 4C FF	y0 50 00 00 0p 0q FF	pq: Gain Position
CAM_GainLimitInq	8x 09 04 2C FF	y0 50 0q FF	p: Gain Limit
CAM_ExpCompModelInq	8x 09 04 3E FF	y0 50 02 FF	On
		y0 50 03 FF	Off
CAM_ExpCompPosInq	8x 09 04 4E FF	y0 50 00 00 0p 0q FF	pq: ExpComp Position
CAM_BackLightModelInq	8x 09 04 33 FF	y0 50 02 FF	On
		y0 50 03 FF	Off
CAM_TallyInq	8x 09 7E 01 0A FF	y0 50 02 FF	On
		y0 50 03 FF	Off
CAM_ResolutionInq	8x 09 06 23 FF	y0 50 0p 0q FF	Pq=Video Resolution
CAM_SpotAEModeInq	8x 09 04 59 FF	y0 50 02 FF	On
		y0 50 03 FF	Off
CAM_SpotAEPosInq	8x 09 04 29 FF	y0 50 0p 0q 0r 0s FF	pq: X Position, rs: Y Position
CAM_WDModelInq	8x 09 04 3D FF	y0 50 02 FF	On
		y0 50 03 FF	Off
		y0 50 06 FF	VE On
CAM_WDParameterInq	8x 09 04 2D FF	y0 50 00 0q 0r 0s 0t 0u 00 00 FF	q: Display brightness level (0: Dark to 6: Bright) r: Brightness compensation selection (0: Very dark, 1: Dark, 2: Standard, 3: Bright) s: Compensation level (00h: Low, 01h: Mid, 02h: High) tu: Always 0
CAM_ApertureInq	8x 09 04 42 FF	y0 50 00 00 0p 0q FF	pq: Aperture Gain

Inquiry Command	Command	Response Packet	Comments
CAM_HRModelInq	8x 09 04 52 FF	y0 50 02 FF	On
		y0 50 03 FF	Off
CAM_NRIInq	8x 09 04 53 FF	y0 50 0p FF	Noise Reduction p: 00h to 05h
CAM_GammaInq	8x 09 04 5B FF	y0 50 0p FF	Gamma p: 00h , 01h
CAM_LR_ReverseModelInq	8x 09 04 61 FF	y0 50 02 FF	On (mirror)
		y0 50 03 FF	Off
CAM_FreezeModelInq	8x 09 04 62 FF	y0 50 02 FF	On
		y0 50 03 FF	Off
CAM_PictureEffectModelInq	8x 09 04 63 FF	y0 50 00 FF	Off
		y0 50 02 FF	Neg. Art
		y0 50 04 FF	Black & White
CAM_PictureFlipModelInq	8x 09 04 66 FF	y0 50 02 FF	On
		y0 50 03 FF	Off
CAM_ICRModelInq	8x 09 04 01 FF	y0 50 02 FF	On
		y0 50 03 FF	Off
CAM_MemoryInq	8x 09 04 3F FF	y0 50 pp FF	pp: Memory number recalled last
CAM_MemoryStatusInq	8x 09 04 3F 0p FF	y0 50 0p 0q 0r 0s FF	p: Memory number q: mode (00-std, 10-std /w ccu, 01-trisync, 11-trisync /w ccu) rs: speed (0x1-0x18) 1 - 24
CAM_MemSaveInq	8x 09 04 23 0X FF	y0 50 0p 0q 0r 0s FF	X: 00h to 07h (Address) pqrs: 0000h to FFFFh (Data)
CAM_DisplayModelInq	8x 09 04 15 FF (8x 09 06 06 FF)	y0 50 02 FF	On
		y0 50 03 FF	Off
CAM_MuteModelInq	8x 09 04 75 FF	y0 50 02 FF	On
		y0 50 03 FF	Off
CAM_IDInq	8x 09 04 22 FF	y0 50 0p 0q 0r 0s FF	pqrs: Camera ID
CAM_VersionInq	8x 09 00 02 FF	y0 50 00 10 mn pq 0E 0E 02 FF	mnpq: Model Code
Vaddio_ModelInq	8x 09 08 0e FF	y0 50 05 00 00 00 00 FF	RoboSHOT 12
		y0 50 05 01 00 00 00 FF	RoboSHOT 30
CAM_RegisterValueInq	8x 09 04 24 mm FF	y0 50 0p 0p FF	mm: Register No. (=00h to 7Fh) pp: Register Value (=00h to FFh)
CAM_ColorEnhanceInq	8x 09 04 20 FF	y0 50 mm 00 pp qq rr ss tt uu FF	mm: Threshold level pp: Y fixed color for high-intensity

Inquiry Command	Command	Response Packet	Comments
			qq: Cr fixed color for high-intensity rr: Cb fixed color for high-intensity ss: Y fixed color for low-intensity tt: Cr fixed color for low-intensity uu: Cb fixed color for low-intensity
	8x 09 04 50 FF	y0 50 02 FF	On
		y0 50 03 FF	Off
CAM_ChromaSuppressInq	8x 09 04 5F FF	y0 50 pp FF	pp: Chroma Suppress setting level
CAM_ColorGainInq	8x 09 04 49 FF	y0 50 00 00 00 0p FF	p: Color Gain Setting 0h to 4h
CAM_ColorHueInq	8x 09 04 4F FF	y0 50 00 00 00 0p FF	p: Color Hue Setting 0h (- 14 degrees) to Eh (+ 14degrees)
CAM_TempInq	8x 09 04 68 FF	Y0 50 00 00 0p 0q FF	pq: Lens Temperature
CAM_GammaOffsetInq	8x 09 04 1E FF	y0 50 00 00 00 0s 0t 0u FF	s: Polarity offset (0 is plus, 1 is minus) tu: Offset s=0 (00h to 40h) Offset s=1 (00h to 10h)
Pan-tiltPosInq	8x 09 06 12 FF	y0 50 0w 0w 0w 0w 0z 0z 0z 0z FF	www= Pan position zzzz=Tilt Position

Command Setting Values – Exposure Control

Shutter Speed

Value	60/59.94/30/29.97	50/25
0x15	1/10000	1/10000
0x14	1/6000	1/6000
0x13	1/4000	1/3500
0x12	1/3000	1/2500
0x11	1/2000	1/1750
0x10	1/1500	1/1250
0x0F	1/1000	1/1000
0x0E	1/725	1/600
0x0D	1/500	1/425
0x0C	1/350	1/300
0x0B	1/250	1/215
0x0A	1/180	1/150
0x09	1/125	1/120
0x08	1/100	1/100
0x07	1/90	1/75
0x06	1/60	1/50
0x05	1/30	1/25
0x04	1/15	1/12
0x03	1/8	1/6
0x02	1/4	1/3
0x01	1/2	1/2
0x00	1/1	1/1

Iris

Value	RoboSHOT 12	RoboSHOT 30
0x11	F1.8	F1.6
0x10	F2	F2
0x0F	F2.4	F2.4
0x0E	F2.8	F2.8
0x0D	F3.3	F3.4
0x0C	F4	F4
0x0B	F4.8	F4.8

Value	RoboSHOT 12	RoboSHOT 30
0x0A	F5.6	F5.6
0x09	F6.8	F6.8
0x08	F8	F8
0x07	F9.6	F9.6
0x06	N/A	F11
0x05	N/A	F14
0x00	CLOSE	CLOSE

Iris gain

Value	Steps
0x0F	28
0x0E	26
0x0D	24
0x0C	22
0x0B	20
0x0A	18
0x09	16
0x08	14
0x07	12
0x06	10
0x05	8
0x04	6
0x03	4
0x02	2
0x01	0

Iris gain limit

Value	Steps
0x0F	28
0x0E	26
0x0D	24
0x0C	22
0x0B	20
0x0A	18

Value	Steps
0x09	16
0x08	14
0x07	12
0x06	10
0x05	8
0x04	6

Exposure comp.

Value	Iris	Gain
0x0E	+7	+10.5 dB
0x0D	+6	+9 dB
0x0C	+5	+7.5 dB
0x0B	+4	+6 dB
0x0A	+3	+4.5 dB
0x09	+2	+3 dB
0x08	+1	+1.5 dB
0x07	0	0 dB
0x06	-1	-1.5 dB
0x05	-2	-3 dB
0x04	-3	-4.5 dB
0x03	-4	-6 dB
0x02	-5	-7.5 dB
0x01	-6	-9 dB
0x00	-7	-10.5 dB

General Specifications

Function	Description
Part Numbers	RoboSHOT 12 HD-SDI, North America – 999-9930-000 RoboSHOT 12 HD-SDI, international – 999-9930-001 RoboSHOT 30 HD-SDI (black), North America – 999-9933-000 RoboSHOT 30 HD-SDI (black), international – 999-9933-001 RoboSHOT 30 HD-SDI (white), North America – 999-9933-000W RoboSHOT 30 HD-SDI (white), international – 999-9933-001W
Image Device	1/2.8-Type Exmor CMOS sensor
HD-SDI and HDMI Video Resolutions	1080p60/59.94/50/30/25, 1080i/60/59.94i/50, 720p/60/59.94/50
Vaddio Special Features	Tri-Synchronous Motion: Concurrent PTZ motor movement and simultaneous PTZ arrival at a stored preset Advanced ISP: Vivid and accurate color reproduction with extremely fast, razor sharp automatic focus and iris routines
Video Aspect Ratio	16:9 aspect ratio for all resolutions
Effective Pixels	2.38 million total pixels 2.14 million effective pixels
RoboSHOT 12 Lens and Horizontal FOV	12X optical zoom, super wide mode: 73.0° (wide) to 6.6° (tele), f=3.91mm to 47.0mm, F1.8 to F3.4 10X optical zoom, normal mode: 67.3° (wide) to 7.6° (tele), f=3.8mm to 38.0mm, F1.8 to F3.4 NOTE: Default is normal mode.
RoboSHOT 30 Lens and Horizontal FOV	30X optical zoom 65° (wide end) to 2.3° (tele end), F1.6 to F4.7
Minimum illumination – RoboSHOT 12	1.0 lx (F1.8, 50IRE), recommended illumination >100 lux and <100,000 lux
Minimum illumination – RoboSHOT 30	1.4 lx (F1.6, 50IRE), recommended illumination >100 lux and <100,000 lux
Minimum working distance – RoboSHOT 12	10mm (wide), 0.8m (tele)
Minimum working distance – RoboSHOT 30	10mm (wide), 1.2m (tele)
S/N ratio	More than 50 dB
Sync system	Internal
White balance	Auto, ATW, Indoor, Outdoor, One-push, Manual (accessible through external control)

Function	Description
Gain	Auto / Manual (0 to 28 steps - accessible through external control)
Back-light compensation	On/Off (IR Remote)
Focusing system	Auto Focus / Manual Focus Mode / One Push Trigger Mode / Infinity Mode / Near Limit Mode
Pan & Tilt Angle/Speed	Pan/Tilt Angles: $\pm 160^\circ$, Tilt: $+90^\circ$, -30° , Pan/Tilt Speeds: Both Axes $0.35^\circ/\text{sec}$ to $120^\circ/\text{sec}$
Noise Reduction	On/Off, 6 Steps, Off through 5 (accessible through external control)
Aperture/Detail	16 Steps (accessible through external control)
Supported Streaming	Simultaneous IP (RTSP format with H.264 compression) up to 1080p/30
Control Interface(s)	Vaddio IR Remote Commander Web interface for network set-up, IP streaming, firmware updates and camera management Telnet serial command API RS-232 API: Modified VISCA Emulation (TTL signal level), Baud rate: 9600 bps and 38,400 bps, 1 stop bit. Default to 9.6 Kb/s for Cat-5e Distance
Connectors	Power 12 VDC: EIAJ-04 Connector with Positive Center Network PoE+: Shielded RJ-45 PoE+ Gigabit Ethernet Port with LEDs to show connection and usage, RTSP Format HD-SDI: Carrier Class, edge mount BNC connector with gold contacts, Compliant with SMPTE 424M (3Gb/s 1080p/60 and 1080p 59.94) HDMI: HDMI jack with screw flange mounted to back panel RS-232: Shielded RJ-45, Carries bidirectional control to and from the camera.
Rear Panel Controls	16-position rotary switch for resolution selection 8-position DIP switch for IR frequency, image flip, wide mode, and reset to default settings
Power Supply	12 VDC, 3.0 Amp Power Supply PoE+ Switch or PoE+ Power Injector (25.5w over Cat-5 at a distance of 328' or 100m)
Compatible Vaddio Controllers	ProductionVIEW Precision Camera Controller ProductionVIEW HD-SDI MV Controller/Switcher
Operating/Storage Temperature/Humidity	0°C (32°F) to 40°C (104°F), 20% to 80% relative humidity
Mass	4.85 lbs.(2.2 kg)
Dimensions	6.942" (176.3mm) H x 7.056" (179.2 mm) W x 6.757" (171.6mm) D,

Specifications are subject to change without notice.

For dimensional drawings, go to support.vaddio.com.



Troubleshooting and Care

When the camera doesn't behave as you expect, check the color of the light on the front before you do anything else.

- Purple – booting or in standby (low power) mode.
- Blue – normal operation.
- Blinking blue – the camera has received a valid IR command.
- Red – Tally function; the camera is on-air.
- Blinking red – fault condition.
- Yellow – firmware update in progress.
- Off – no power to the camera.

Stuff happens – we get it. Use this table to determine whether it's time to call Vaddio Technical Support.

What is it doing?	Possible causes	Check and correct
Nothing. The light on the front is off.	If a OneLINK extension system is used: The camera is not connected to the EZIM.	Plug the EZIM into the camera.
	If a OneLINK extension system is used: The EZIM is not connected to the main OneLINK interface, or the OneLINK power supply is not connected.	Connect the EZIM to its parent OneLINK interface, or plug the power pack into a wall outlet.
	At least one of the cables is bad.	Check using known good cables.
	If a OneLINK extension system is used: The OneLINK system is not working properly.	Connect the camera directly to the 12V power pack that was shipped with it to determine where the problem is. Caution <i>Do not connect the camera to the OneLINK power pack. This will damage the camera and void its warranty.</i> If the camera works when it is connected without a OneLINK system, the OneLINK system is bad. Contact your reseller or Vaddio Technical Support.
	The wall outlet is not active. (Check by finding out if it powers something else, such as a laptop or phone charger.)	Use a different outlet.
	The camera or its power supply is bad.	Contact your reseller or Vaddio Technical Support.
The camera is not responding to the remote and the light is yellow.	A firmware update is in progress.	Wait a few minutes, and try again when the light turns blue.

What is it doing?	Possible causes	Check and correct
The camera does not respond to the remote, but the web interface is available	The batteries in the remote are dead.	Put new batteries in the remote.
The camera responds to the remote but the web interface is not available.	The camera is not using the IP address you browsed to.	Press the Data Screen button on the remote to see camera information.
The camera's web UI is available but the camera does not respond to commands via RS-232 connection.	The camera's RS-232 settings don't match the settings on the controlling device.	Check the settings at both ends - the camera's current settings are available on the Camera Settings page in the web UI. Correct the settings where it's more convenient to do so.
The camera loses all its settings when power is cycled.	All the DIP switches are in the ON (down) position.	Set the DIP switches to their proper positions. Default is all OFF (up). See Switch Settings for more information.
No H.264 video stream.	Streaming is not enabled.	Enable streaming: Streaming page in the web interface.

Operation, Storage, and Care

For smears or smudges on the product, wipe with a clean, soft cloth. Use a lens cleaner on the lens. Do not use any abrasive chemicals.

Keep this device away from food and liquids.

Do not operate or store the device under any of the following conditions:

- Temperatures above 40°C (104°F) or below 0°C (32°F)
- High humidity, condensing or wet environments
- Inclement weather
- Severe vibration
- Between converging tectonic plates
- Dry environments with an excess of static discharge

Do not attempt to take this product apart. There are no user-serviceable components inside.

Compliance Statements and Declarations of Conformity

Compliance testing was performed to the following regulations:

FCC Part 15 (15.107, 15.109), Subpart B	Class A
ICES-003, Issue 54: 2012	Class A
EMC Directive 2004/108/EC	Class A
EN 55022: December 2010	Class A
EN 55024: November 2010	Class A
KN22 2008 (CISPR 22: 2006)	Class A
KN24 2008 (CISPR 24: 1997 + A1: 2000 + A2: 2002)	Class A
IEC 60950-1:2005 (2nd Edition); Am 1: 2009 + Am 2: 2013	Safety
EN 60950-1: 2006 + A11: 2009 + A1: 2010 + A12: 2011 + A2: 2013	Safety

FCC Part 15 Compliance

This equipment has been tested and found to comply with the limits for a Class A digital device, pursuant to Part 15, Subpart B, of the FCC Rules. These limits are designed to provide reasonable protection against harmful interference when the equipment is operated in a commercial environment. This equipment generates, uses, and can radiate radio frequency energy and, if not installed and used in accordance with the instruction manual, may cause harmful interference to radio communications. Operation of this equipment in a residential area is likely to cause harmful interference in which case the user will be required to correct the interference at his/her own expense.

Operation is subject to the following two conditions: (1) This device may not cause interference, and (2) This device must accept any interference including interference that may cause undesired operation of the device.



Changes or modifications not expressly approved by Vaddio can affect emission compliance and could void the user's authority to operate this equipment.

ICES-003 Compliance

This digital apparatus does not exceed the Class A limits for radio noise emissions from digital apparatus set out in the Radio Interference Regulations of the Canadian Department of Communications.

Le présent appareil numérique n'émet pas de bruits radioélectriques dépassant les limites applicables aux appareils numériques de la classe A prescrites dans le Règlement sur le brouillage radioélectrique édicté par le ministère des Communications du Canada.

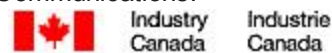

European Compliance

This product has been evaluated for Electromagnetic Compatibility under the EMC Directive for Emissions and Immunity and meets the requirements for a Class A digital device. In a domestic environment this product may cause radio interference in which case the user may be required to take adequate measures.

Standard(s) To Which Conformity Is Declared:



EMC Directive 2004/108/EC

EN 55022: December 2010

EN 55024: November 2010

EN 61000-4-2: 1995 + Amendments A1: 1998 + A2: 2001

EN 61000-4-3: 2006 + A1: 2008

EN 61000-4-4: 2004 + Corrigendum 2006

EN 61000-4-5: 2006

EN 61000-4-6: 2009

EN 61000-4-8: 2010

EN 61000-4-11: 2004

KN22 2008 (CISPR 22: 2006)

KN24 2008 (CISPR 24: 1997 + A1: 2000 + A2: 2002)

EN 61000-4-2

EN 61000-4-3

EN 61000-4-4

EN 61000-4-5

EN 61000-4-6

EN 61000-4-8

EN 61000-4-11

IEC 60950-1: 2005 (2nd Edition); Am 1: 2009 + Am 2: 2013

EN 60950-1: 2006 + A11: 2009 + A1: 2010 + A12: 2011 + A2: 2013

Conducted and Radiated Emissions

Immunity

Electrostatic Discharge

Radiated Immunity

Electrical Fast Transients

Surge Immunity

Conducted Immunity

Power Frequency Magnetic Field

Voltage Dips, Interrupts and Fluctuations

Conducted and Radiated Emissions

IT Immunity Characteristics

Electrostatic Discharge

Radiated Immunity

Electrical Fast Transients

Surge Immunity

Conducted Immunity

Power Frequency Magnetic Field

Voltage Dips, Interrupts and Fluctuations

Safety

Safety

Warranty Information

See Vaddio Warranty, Service and Return Policies posted on vaddio.com for complete details.

Hardware* Warranty: Two (2) year limited warranty on all parts and labor for Vaddio manufactured products. Vaddio warrants its manufactured products against defects in materials and workmanship for a period of two years from the day of purchase, to the original purchaser, if Vaddio receives notice of such defects during the warranty. Vaddio, at its option, will repair or replace products that prove to be defective. Vaddio manufactures its hardware products from parts and components that are new or equivalent to new in accordance with industry standard practices.

Exclusions: The above warranty shall not apply to defects resulting from improper or inadequate maintenance by the customer, customers applied software or interfacing, unauthorized modifications or misuse, mishandling, operation outside the normal environmental specifications for the product, use of the incorrect power supply, modified power supply or improper site operation and maintenance. OEM and Special Order products manufactured by other companies are excluded and are covered by the manufacturer's warranty.

Vaddio Customer Service: Vaddio will test, repair, or replace the product or products without charge if the unit is under warranty. If the product is out of warranty, Vaddio will test then repair the product or products. The cost of parts and labor charge will be estimated by a technician and confirmed by the customer prior to repair. All components must be returned for testing as a complete unit. Vaddio will not accept responsibility for shipment after it has left the premises.

Vaddio Technical Support: Vaddio technicians will determine and discuss with the customer the criteria for repair costs and/or replacement. Vaddio Technical Support can be contacted through one of the following resources: e-mail support at support@vaddio.com or online at vaddio.com.

Return Material Authorization (RMA) Number: Before returning a product for repair or replacement request an RMA from Vaddio's technical support. Provide the technician with a return phone number, e-mail address, shipping address, product serial numbers and original purchase order number. Describe the reason for repairs or returns as well as the date of purchase. See the General RMA Terms and Procedures section for more information. RMA's are valid for 30 days and will be issued to Vaddio dealers only. End users must return products through Vaddio dealers. Include the assigned RMA number in all correspondence with Vaddio. Write the assigned RMA number clearly on the shipping label of the box when returning the product. All products returned for credit are subject to a restocking charge without exception. Special Order product are not returnable.

Voided Warranty: The warranty does not apply if the original serial number has been removed or if the product has been disassembled or damaged through misuse, accident, modifications, use of incorrect power supply, use of a modified power supply or unauthorized repair.

Shipping and Handling: Vaddio will not pay for inbound shipping transportation or insurance charges or accept any responsibility for laws and ordinances from inbound transit. Vaddio will pay for outbound shipping, transportation, and insurance charges for all items under warranty but will not assume responsibility for loss and/or damage by the outbound freight carrier. If the return shipment appears damaged, retain the original boxes and packing material for inspection by the carrier. Contact your carrier immediately.

Products not under Warranty: Payment arrangements are required before outbound shipment for all out of warranty products.

Index

A

- admin login 14-15, 23
 - changing 23
 - default 14
- anatomy of the camera 5
- API 32, 44
 - syntax help 44
- auto focus 12, 35

B

- back light compensation 12, 37-38
- baud rate setting 6
- browser compatibility 14

C

- cable connectors 9
- camera ID setting (DIP switch) 6
- camera select 12, See also camera ID setting (DIP switch)
- CCU scenes 20, 25, 39
 - custom 20, 25, 39
 - recalling 39
- CCU settings 36-38
- cleaning 64
- color settings 20, 25, 37-38
- color space setting 6
- colors of the status light 5
- command history 43
- compatibility, browsers 14
- connector identification 6
- custom CCU scenes 25

D

- damage, preventing 9
- default IP address 14
- default settings, restoring 28
- detail setting 38
- DHCP 21

- diagnostic logs 30
- DIP switch settings 6
- directional controls 12

F

- factory defaults, restoring 28
- firmware update 29
- focus 12, 18, 35

G

- getting help 31
- guest access 15, 23
 - allowing 23

H

- HDMI resolution, setting 6
- help 31
- home position 24, 32
- hostname 21

I

- image flip setting (DIP switch) 6
- information, conference room 22
- IP address 14, 21
 - default 14, 21
- IP settings for streaming 40
- IR forwarding (DIP switch) 6
- iris settings 37-38

L

- labels, room 22
- lighting settings 25, 37-38
- locations of connectors 6
- log files 30
- login 14-15
 - admin 14-15
 - user 14

M

- manual focus 12
- mounting cameras 9

N

network configuration 14, 21
 default 14, 21

O

operating environment 64

P

pan 33
pan/tilt/zoom 12, 18, 25
passwords 23
ping command 41
power on/power off 12
presets 12-13, 18-19, 36
 clearing 12
 moving to 12, 18, 36
 setting 12-13, 19, 36
product returns and repairs 67

R

rebooting the camera 28
remote control 12
resolution 6, 26
 streaming 26
 switch setting 6
restoring default settings 28
RJ-45 connectors 9
room information 22

S

scenes, CCU 20, 25
 naming 25
 storing 25
software update 29
speed 18, 25, 33-35
 focus 35
 pan/tilt/zoom 18, 25, 33-34
standby 17, 39
start-up behavior, setting 24
static IP address 21

status light, meanings of colors 5
storage environment 64
streaming settings 26, 40
super-wide mode setting (DIP switch) 6
supported web browsers 14
switch settings 6, 28
 baud rate (DIP switch) 6
 camera ID (DIP switch) 6
 color space (DIP switch) 6
 image flip (DIP switch) 6
 IR forwarding (DIP switch) 6
 reading 28
 super wide mode (DIP switch) 6
 video resolution 6
switch, video resolution 6

T

technical support 31
Telnet session 32, 43-44
 ending 44
 history 43
temperature 64
tilt 33
Tri-Synchronous Motion (Tri-Sync) 19, 36

U

update 29
user login 14, 23
 changing 23
 default 14

V

video resolution setting 6

W

warranty 9, 67
web browsers supported 14

Z

zoom 34
zoom speed 12, 18, 34

RoboSHOT HD-SDI, EZCamera, ProductionVIEW, and IR Remote Commander are trademarks of Vaddio, LLC. The terms HDMI and HDMI High-Definition Multimedia Interface, and the HDMI Logo are trademarks or registered trademarks of HDMI Licensing LLC in the United States and other countries. Exmor is a trademark of Sony Corporation. All other trademarks in this document are the property of their respective owners.

Copyright © 2015 Vaddio, LLC. All rights reserved.

Vaddio, LLC

131 Cheshire Ln., Suite 500

Minnetonka, MN 55305



205 Westwood Ave, Long Branch, NJ 07740

Phone: 866-94 BOARDS (26273) / (732)-222-1511

Fax: (732)-222-7088 | E-mail: sales@touchboards.com

