

# Installation and Assembly - Electrical Outlet Strip with Cord Wrap

Models: ACC 320

**IMPORTANT!** Read entire instruction sheet before you start installation and assembly.

For customer care call 1-800-729-0307 or 708-865-8870. Visit the Peerless Web Site at [www.peerlessmounts.com](http://www.peerlessmounts.com).

Before you start make sure all parts shown below are included with your product.

## Parts List

DESCRIPTION	QTY.	PART #
A cord wrap - clip	1	009-1023
B 20' extension cord	1	600-1006
C M5 x 12mm phillips head pan screw	2	520-1027

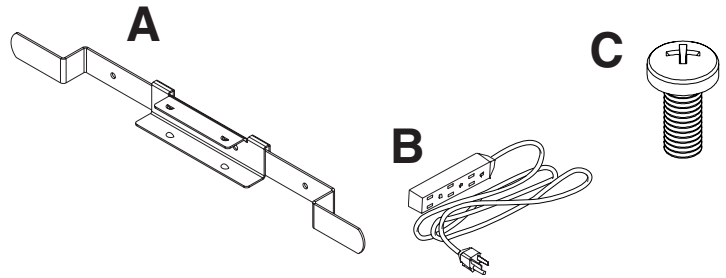

Note: Some parts may appear slightly different than illustrated.

**1** Attach cord wrap (A) to cart base using two M5 x 10 mm phillips head pan screws (C) as shown. Tighten securely.

**NOTE:** Cord wrap does not hook into base.

**1-1** Next press extension cord (B) into center of mounting clip (A) as shown in fig. 1.1.

**1-2** Wrap extension cord (B) around cord wrap (A) as shown in fig. 1.2.

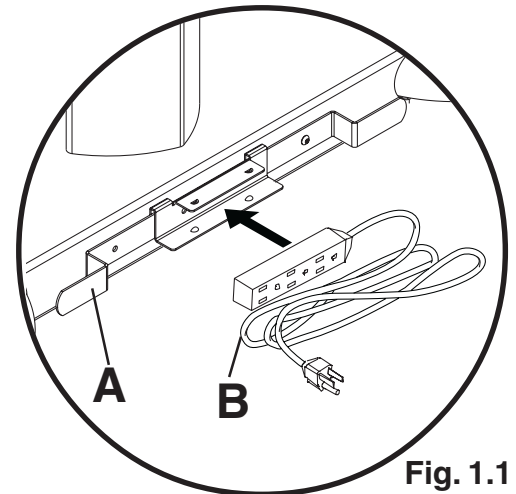
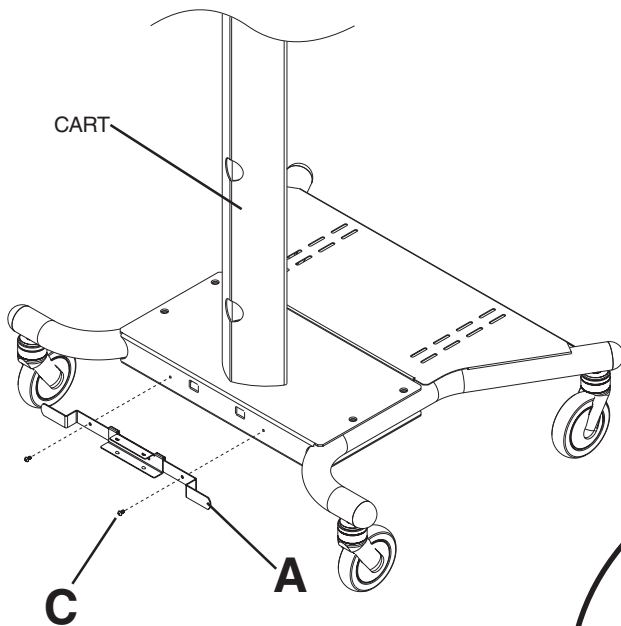

Fig. 1.1

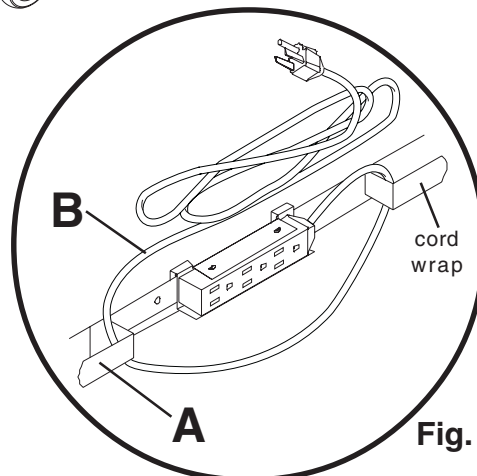

Fig. 1.2

# Touchboards

205 Westwood Ave, Long Branch, NJ 07740  
 Phone: 866-94 BOARDS (26273) / (732)-222-1511  
 Fax: (732)-222-7088 | E-mail: [sales@touchboards.com](mailto:sales@touchboards.com)