

Installation and Assembly - Anti-Vibration Ceiling Mount

Models: ACC 840
ACC 845

This product is to be used in combination with model PJC 100 Projector Mount.



IMPORTANT! Read entire instruction sheet before you start installation and assembly.

WARNING

- Installer must verify that the wall will safely support four times the combined weight of projector mount and video projector.

Before you start check the parts list below to make sure all of the parts shown are included.

Parts List

Description	Qty.	Part Number
A ceiling mount bracket	1	055-1173
B support bracket	1	055-1174
C 1/4-20 x 3/8" socket bolt	4	520-2015
D rubber mount	4	560-1135
E split washer	4	540-9402
F 1/4-20 hex head nut	4	530-9302

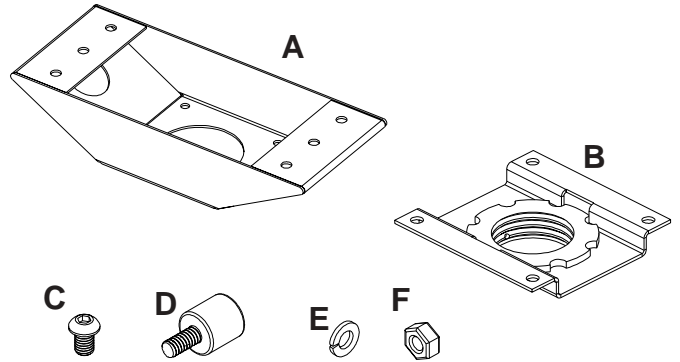

Note: Actual parts may appear slightly different than illustrated.

- 1 Fasten four rubber mounts (D) to ceiling bracket (A) using four 1/4-20 socket bolts (C).

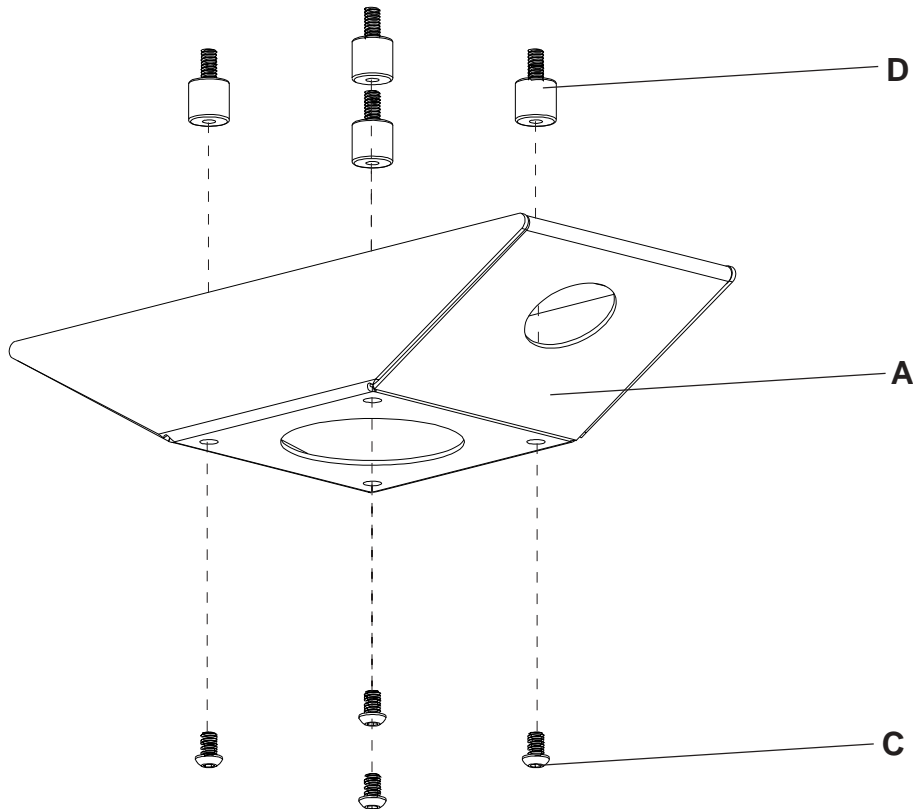

2

Place support bracket (B) on top rubber mounts (D) then fasten using four split washers (E) and four 1/4-20 nuts (F). **Note: Make sure that open end of support bracket is faced outward.**

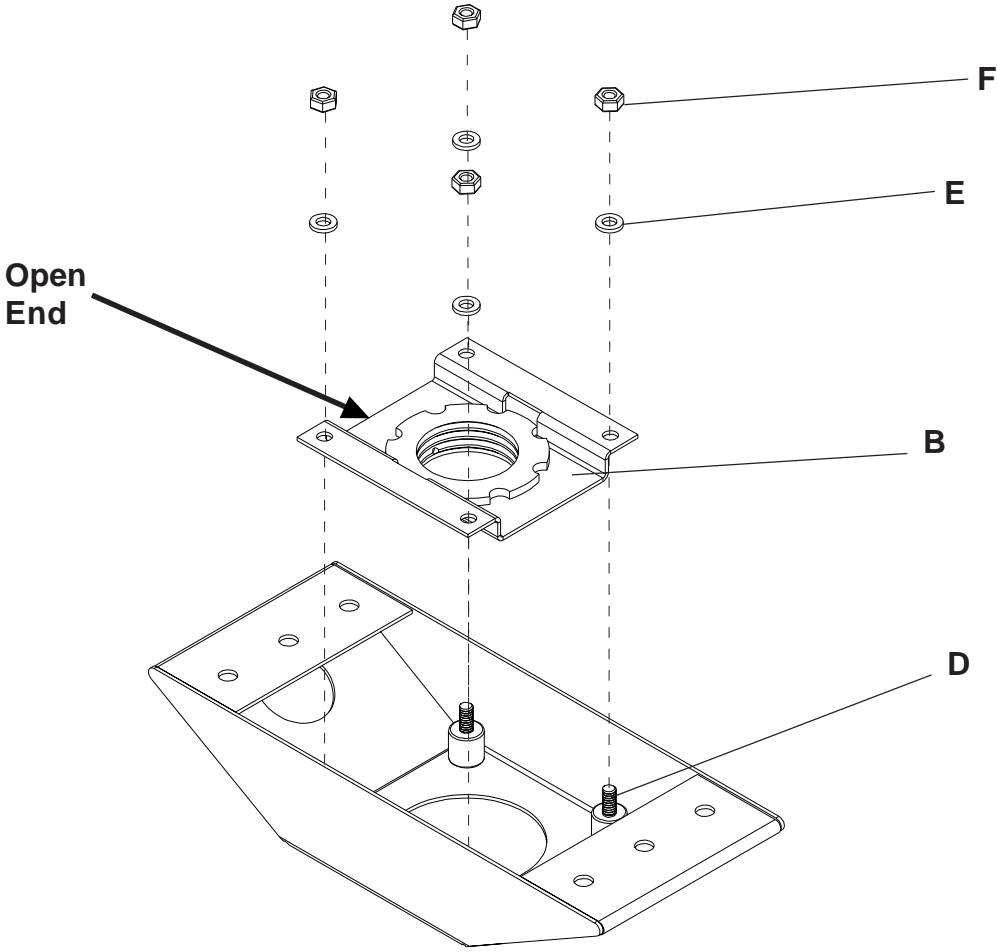

205 Westwood Ave, Long Branch, NJ 07740
Phone: 866-94 BOARDS (26273) / (732)-222-1511
Fax: (732)-222-7088 | E-mail: sales@touchboards.com