

IMPORTANT! Read entire instruction sheet before you start installation and assembly.

Before you start check the parts list below to make sure all of the parts shown are included.

⚠ WARNING

- Installer must verify that the ceiling will safely support four times the combined weight of all attached equipment and hardware.

Parts List

Description	Qty.	Part Number
A anti-vibration mount	1	055-0004
B rubber bumper	4	590-1124
C plastic finishing caps	2	590-1123
D adapter bracket for unistrut	2	055-1175
E 5/16-18 x 1.25 socket bolt	2	520-1104
F rubber grommet	1	530-9401
G M5 x .8 x 10 mm socket-pin screw	1	520-1063
H M5 x .8 x 10 mm phillips screw	1	520-9250
I spring nut	2	560-2101

Note: Actual parts may appear slightly different than illustrated.

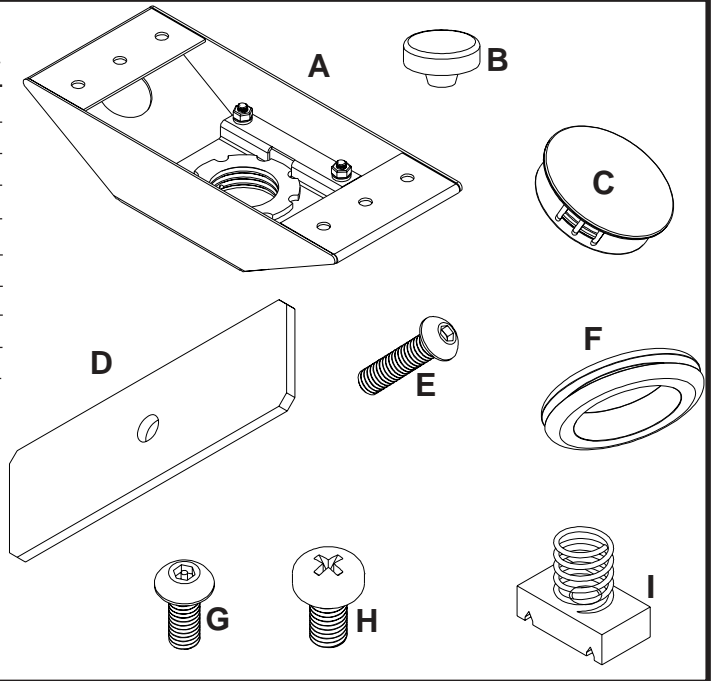

⚠ WARNING

- If mounting to wood, purchase model ACC 840. Model ACC 845 should be mounted to Unistrut® only. If the anti-vibration mount is altered in any way it may not be as effective, or effective at all, in controlling vibration. In addition, be certain that no part of the system, including any extension column that might be used, comes in contact with the vibrating surface. If mounting through a drop ceiling, be sure to cut a large enough hole in the ceiling tile as to avoid contact with the extension column. If using an escutcheon ring, be sure it does not come in contact with the false ceiling. Also be sure to use the rubber bumpers (B) provided.



205 Westwood Ave, Long Branch, NJ 07740
 Phone: 866-94 BOARDS (26273) / (732)-222-1511
 Fax: (732)-222-7088 | E-mail: sales@touchboards.com

- 1** Attach four rubber bumpers (**B**) to anti-vibration mount (**A**) as shown below.

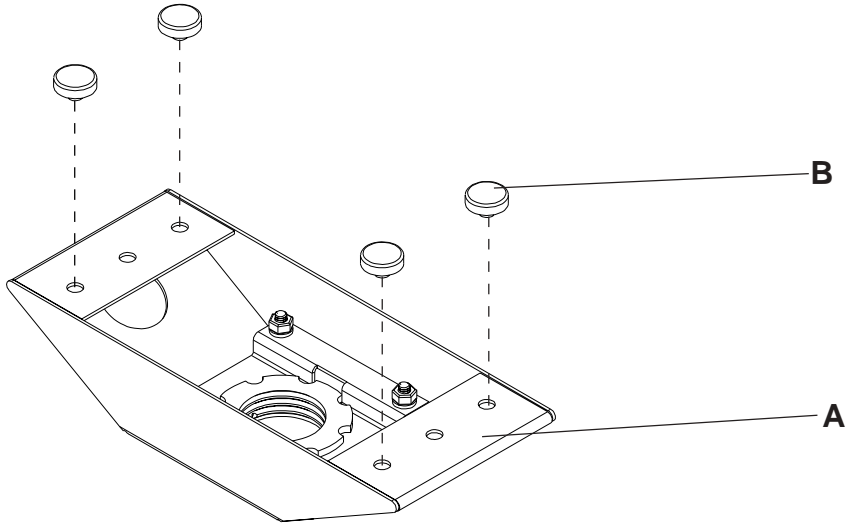

- 2** Insert two spring nuts (**I**) into Unistrut® track as shown.

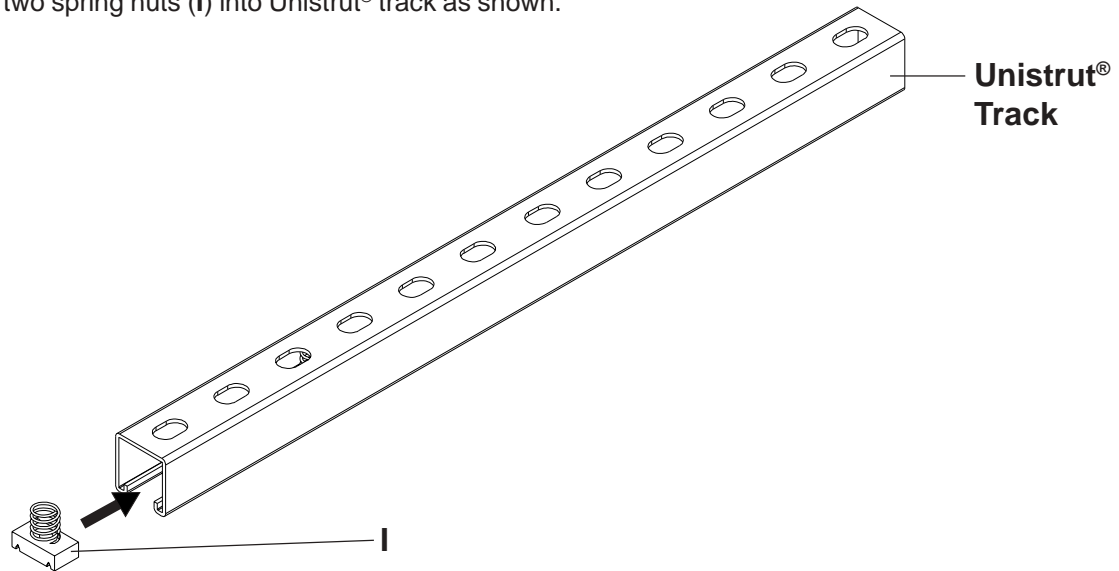

- 3** Place adapter brackets (D) on top of rubber bumper (B) then fasten to spring nuts (I) inside Unistrut® track using two 5/16-18 socket bolts (E). **Note:** Make sure rubber bumpers (B) are firmly in place before attaching to ceiling.

⚠ WARNING

- Tighten socket bolts so that anti-vibration mount is firmly attached, but do not overtighten. Overtightening can damage the bolts, greatly reducing their holding power and decrease the anti-vibrational effectiveness!
- Tighten to 30-40 in • lb (3.4 - 4.5 N.M.) maximum torque.

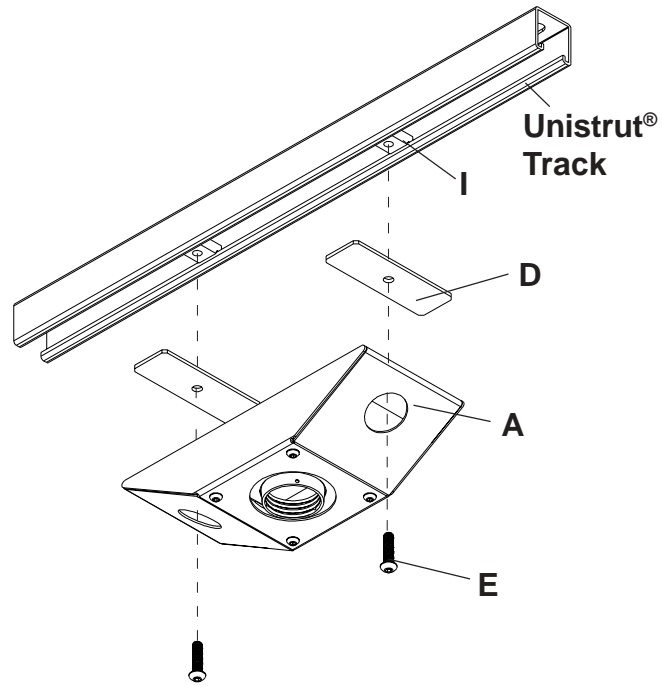

- 4** When attaching anti-vibration mount (A) to flush mount tube or extension column (both tube and column are sold separately), tighten at least four complete turns ending with one of the small threaded holes aligned with slot in the end of flush mount tube or extension column. Insert and tighten one M5 screw (H) to lock tube position (shown below on right side). **Note: For security the M5 philips screw (H) can be replaced with M5 socket pin screws (G).**

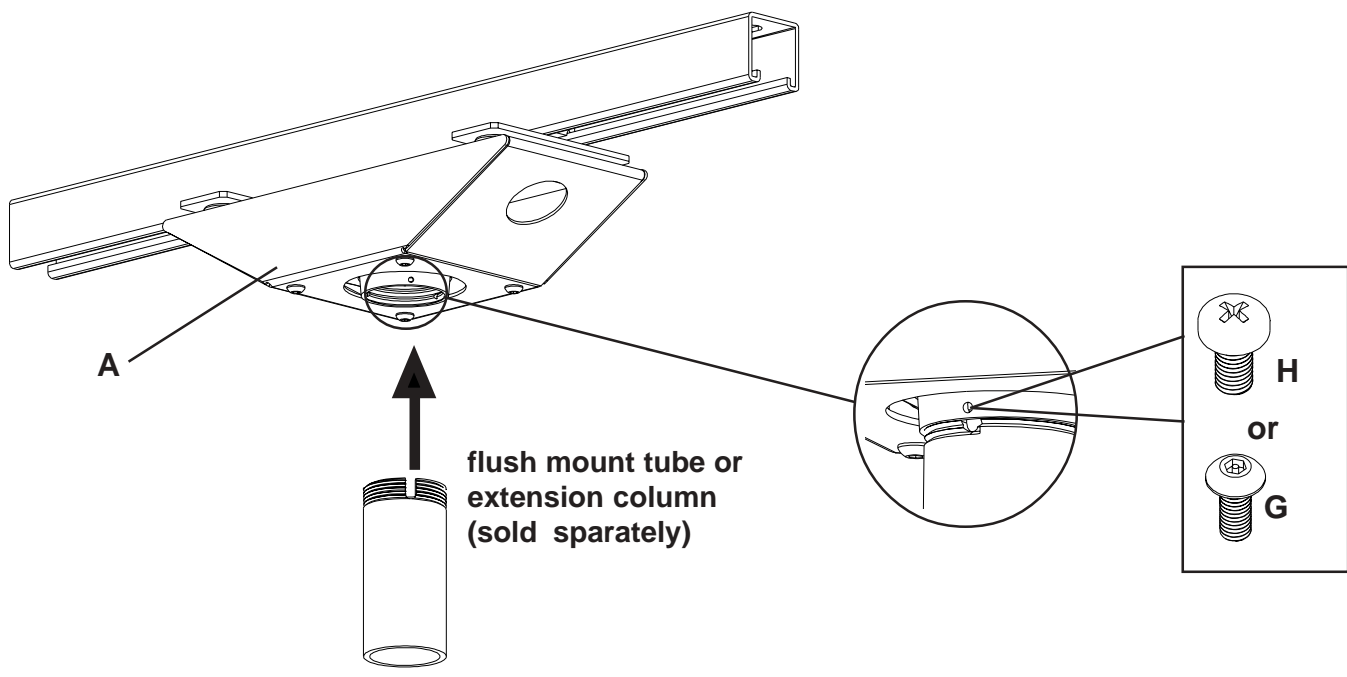

5 Place one finishing cap (**C**) on each end of anti-vibration mount (**A**).

OPTIONAL: Place grommet (**F**) on anti-vibration mount (**A**) and place one finishing cap (**C**) on other end of anti-vibration mount (**A**). Route cords through extension column and out cord management holes in anti-vibration mount (**A**).

Note: If using Vector Pro projector mounts, you will need accessory ACC 800 to route cords through column.

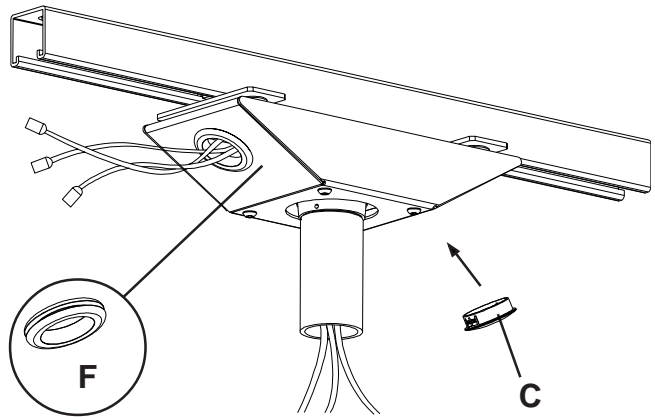
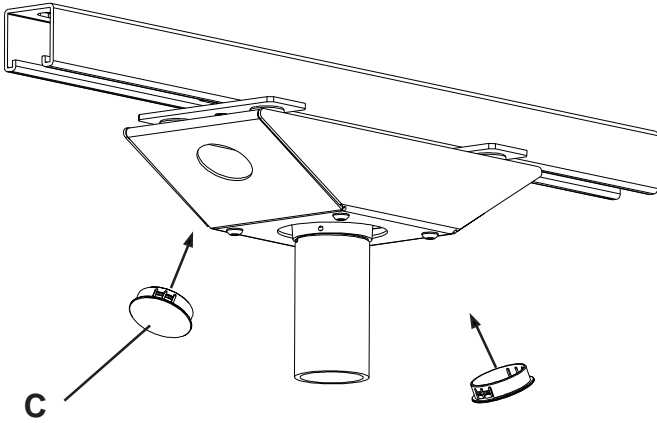

Touchboards

205 Westwood Ave, Long Branch, NJ 07740
Phone: 866-94 BOARDS (26273) / (732)-222-1511
Fax: (732)-222-7088 | E-mail: sales@touchboards.com