

ACC952

Above Display SUF Security Lock Accessory For Ultra-thin Flat Panel Displays mounted on Peerless SUF models

Provide an extra sense of security for ultra-thin flat panel displays mounted on Peerless SUF models by adding the ACC952. This unique accessory attaches with security screws into the wood studs above the flat panel display and SUF mount, preventing unwanted horizontal adjustments and deterring theft by preventing the display from being lifted off of the mount. The included Masterlock®510KAD padlocks provide additional security by sliding into the accessory, preventing access to the security screws, and offer convenience by being keyed alike.



FEATURES

- Prevents the flat panel display from being lifted off of the SUF mount
- Easy installation into the studs above the ultra-thin flat panel display with security screws
- Masterlock®510KAD padlocks obstruct access to security screws
- Padlocks are keyed alike for convenience
- Compatible with any Peerless SUF mount
- Stylish cover creates a finished look

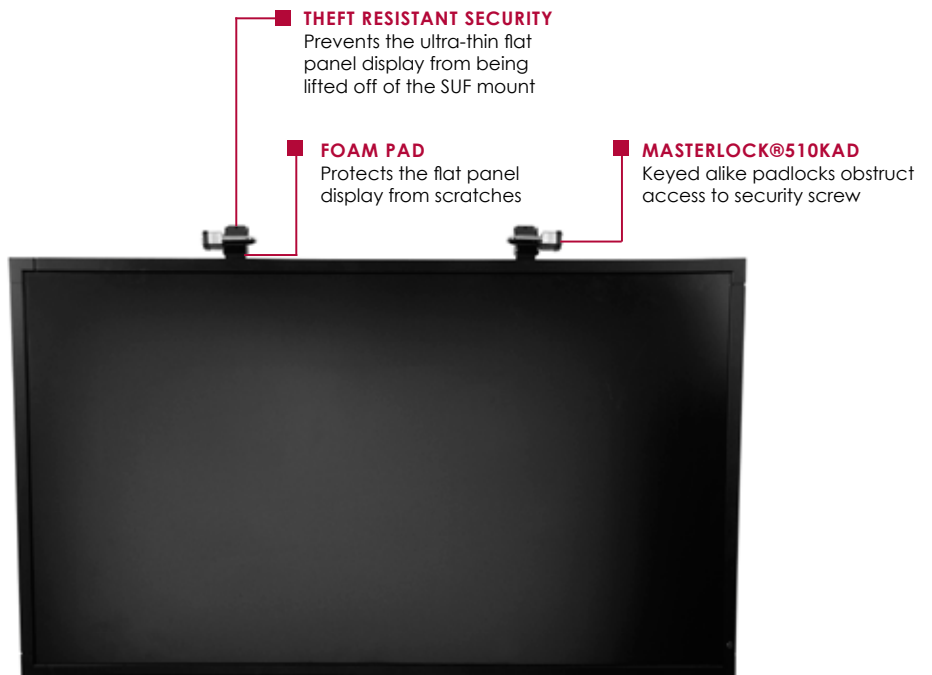

Easily attach accessory to studs with security screw



Keyed alike padlocks prevents tampering with security screw by obstructing access to it

RoHS
2002/95/EC

Touchboards

205 Westwood Ave, Long Branch, NJ 07740
Phone: 866-94 BOARDS (26273) / (732)-222-1511
Fax: (732)-222-7088 | E-mail: sales@touchboards.com

peerless-AV™

ACC952: Above Display SUF Security Lock Accessory for Ultra-thin Flat Panel Displays mounted on Peerless SUF models

Product Specifications

	DIMENSIONS (W x H x D)	PRODUCT WEIGHT	LOAD CAPACITY	FINISH	AVAILABLE COLORS
ACC952	1.33" x 1.72" x 2.00" (34 x 44 x 51mm)	1.49lb (.68kg)	N/A	TGIC Polyester Powder Coat	Gloss Black

Package Specifications

	PACKAGE SIZE (W x H x D)	PACKAGE SHIP WEIGHT	PACKAGE UPC CODE	PACKAGE CONTENTS	UNITS IN PACKAGE
ACC952	4.375" x 4.375" x 8.75" (111.125 x 111.125 x 222.25mm)	2lb (.91kg)	735029278481	Two Lock Accessories, two keyed alike Masterlock®510KAD padlocks and wall attachment security hardware	1

All dimensions = inch (mm)

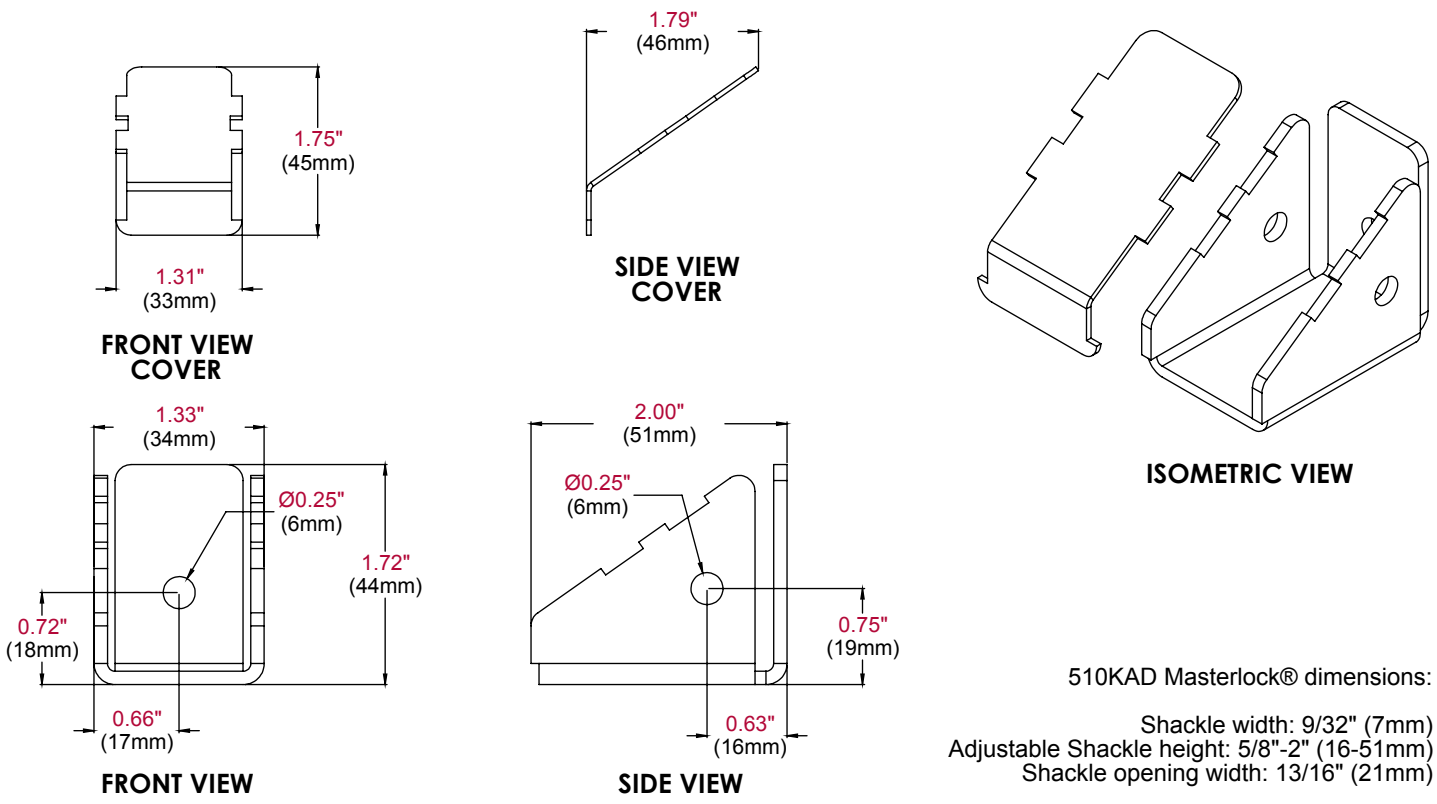

ARCHITECTS SPECIFICATIONS

Above Display SUF Security Lock Accessory shall be a Peerless-AV model ACC952 and shall be installed where indicated on the plans. It shall be constructed of heavy gauge cold rolled steel and finished with scratch resistant black fused epoxy. Assembly and installation shall be done according to instructions provided by the manufacturer.