

■ DC/AC MICROPROBE

K100

K110

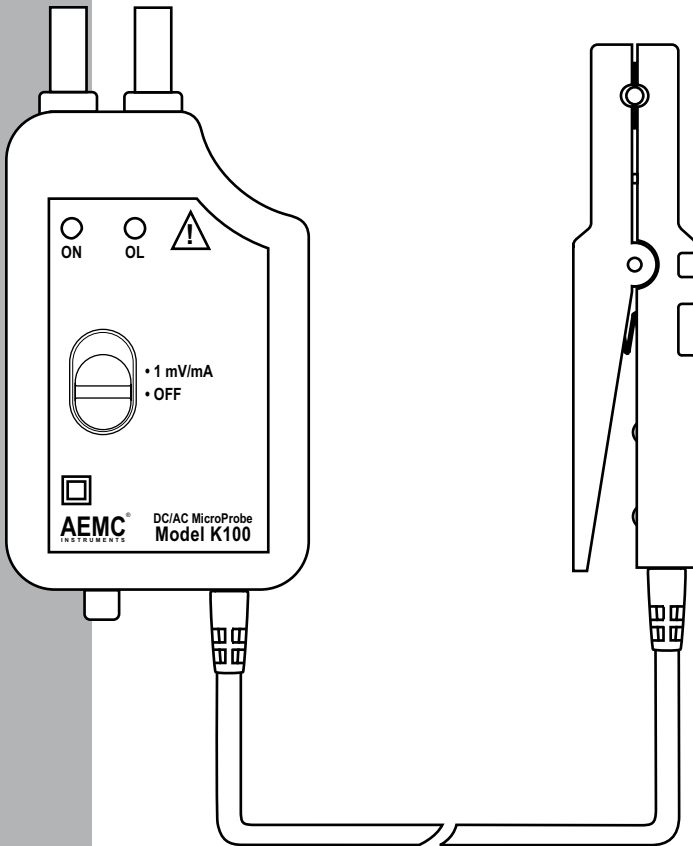

Statement of Compliance

Chauvin Arnoux®, Inc. d.b.a. AEMC® Instruments certifies that this instrument has been calibrated using standards and instruments traceable to international standards.

We guarantee that at the time of shipping your instrument has met its published specifications.

An NIST traceable certificate may be requested at the time of purchase, or obtained by returning the instrument to our repair and calibration facility, for a nominal charge.

The recommended calibration interval for this instrument is 12 months and begins on the date of receipt by the customer. For recalibration, please use our calibration services. Refer to our repair and calibration section at www.aemc.com.

Serial #: _____

Catalog #: 1200.67 / 2111.73

Model #: K100 / K110

Please fill in the appropriate date as indicated:

Date Received: _____

Date Calibration Due: _____



AEMC®
INSTRUMENTS

Chauvin Arnoux®, Inc.
d.b.a AEMC® Instruments
www.aemc.com

Table of Contents

1. INTRODUCTION	3
1.1 International Electrical Symbols	3
1.2 Definition of Measurement Categories	4
1.3 Receiving Your Shipment	4
1.4 Ordering Information	4
2. PRODUCT FEATURES	5
2.1 Description	5
2.2 Model K100 Features	6
2.3 Model K110 Features	7
3. SPECIFICATIONS	8
3.1 Electrical Specifications	8
3.2 Environmental Specifications	9
3.3 Mechanical Specifications	9
3.4 Safety Specifications	9
3.5 Typical Frequency Response	10
4. OPERATION	11
4.1 Making Measurements with the K100/K110	11
4.2 Indicator Lights - Green and Red LEDs	11
4.3 Model K100 Operation Examples	12
DC Current Measurement Example (K100)	12
DC Current Measurement Example - Current Reversed	12
Two-Wire Sum-of-Currents Example (K100)	13
Two-Wire Current Differential Example (K100)	13
Oscilloscope Measurement Example (K100)	14
Maximum Step Discontinuity Example (K100)	14
4.4 Model K110 Operation Examples	15
Measuring the DC Component of an (AC+DC) Waveform	15
Measuring the AC Component of an (AC+DC) Waveform	15
Oscilloscope Measurement Example (K110)	16
4.5 Tips For Making Precise Measurements	16
4.6 Residual Readings Following Severe Overloads	19

5. MAINTENANCE 20

- 5.1 Warning20
- 5.2 Battery Installation20
- 5.3 Cleaning.....21

Repair and Calibration.....22

Technical and Sales Assistance22

Limited Warranty23

Warranty Repairs.....23

INTRODUCTION



These safety warnings are provided to ensure the safety of personnel and proper operation of the instrument.

- Read the instruction manual completely and follow all the safety information before attempting to use or service this instrument.
- Use caution on any circuit: Potentially high voltages and currents may be present and may pose a shock hazard.
- Read the Safety Specifications section prior to using the Model K100/K110. Never exceed the maximum voltage ratings given.
- Safety is the responsibility of the operator.
- NEVER open the back of the instrument while connected to any circuit or input.
- ALWAYS connect the Model K100/K110 adapter to the display device before clamping the probe onto the sample under test.
- ALWAYS inspect the instrument, probe, probe cable and output terminals prior to use. Replace any defective parts immediately.
- NEVER use the Model K100/K110 on electrical conductors rated above 300V CAT II, EN61010-1.

1.1 International Electrical Symbols



This symbol signifies that the instrument is protected by double or reinforced insulation. Use only specified replacement parts when servicing the instrument.



This symbol on the instrument indicates a WARNING and that the operator must refer to the user manual for instructions before operating the instrument. In this manual, the symbol preceding instructions indicates that if the instructions are not followed, bodily injury, installation/sample and product damage may result.



Risk of electric shock. The voltage at the parts marked with this symbol may be dangerous.

1.2 Definition of Measurement Categories

CAT II: For measurements performed on circuits directly connected to the electrical distribution system. Examples are measurements on household appliances or portable tools.

CAT III: For measurements performed in the building installation at the distribution level such as on hardwired equipment in fixed installation and circuit breakers.

CAT IV: For measurements performed at the primary electrical supply (<1000V) such as on primary overcurrent protection devices, ripple control units, or meters.

1.3 Receiving Your Shipment

Upon receiving your shipment, make sure that the contents are consistent with the packing list. Notify your distributor of any missing items. If the equipment appears to be damaged, file a claim immediately with the carrier and notify your distributor at once, giving a detailed description of any damage.

1.4 Ordering Information

DC/AC MicroProbe Model K100..... **Cat. #1200.67**

DC/AC MicroProbe Model K110..... **Cat. #2111.73**

Both models include an electronic plug-in module with an attached current probe, 9V battery, and user manual

Order Accessories and Replacement Parts Directly Online

Check our Storefront at www.aemc.com/store for availability

PRODUCT FEATURES

2.1 Description

Model K100 and Model K110 are low current measurement instruments that feature a compact, high sensitivity current probe. Unlike other instruments, the Model K100 exhibits a wide dynamic operating range, which extends from below $100\mu\text{A}$ to $\pm 4.5\text{A}$ peak, from DC to 2.0kHz^* , without the need for ranging. The K110 has an operating range of $100\mu\text{A}$ to $\pm 450\text{mA}$ Peak, from DC to 1500Hz^* .

Models K100 and K110 are designed to be operated in conjunction with a digital multimeter, oscilloscope or recording device. The MicroProbe outputs the current measured in the form of a voltage that is the image of the current, in shape and amplitude. The Model K100 outputs 1mV per mA of measured current. The Model K110 outputs 10mV per mA of measured current. To take advantage of the Model K100 high sensitivity, best results are obtained through 4-1/2 digit (or more) DMM with a relative zero function. The Model K110 was designed to provide the operator with enhanced low current linearity and accuracy, but is limited to 450mA Peak current.

The Model K100/K110 always outputs a signal proportional to the total current (AC+DC) in the conductor under test. This has proven to be the most versatile signal output format, and allows the user to isolate and measure DC and AC components of measured current separately, if so desired. Typical applications include 4 to 20mA loop measurements, automotive current applications, benchtop electronic current consumption in circuits, and other applications requiring very low current measurements in crowded areas.

** See Electrical Specifications*

2.2 Model K100 Features

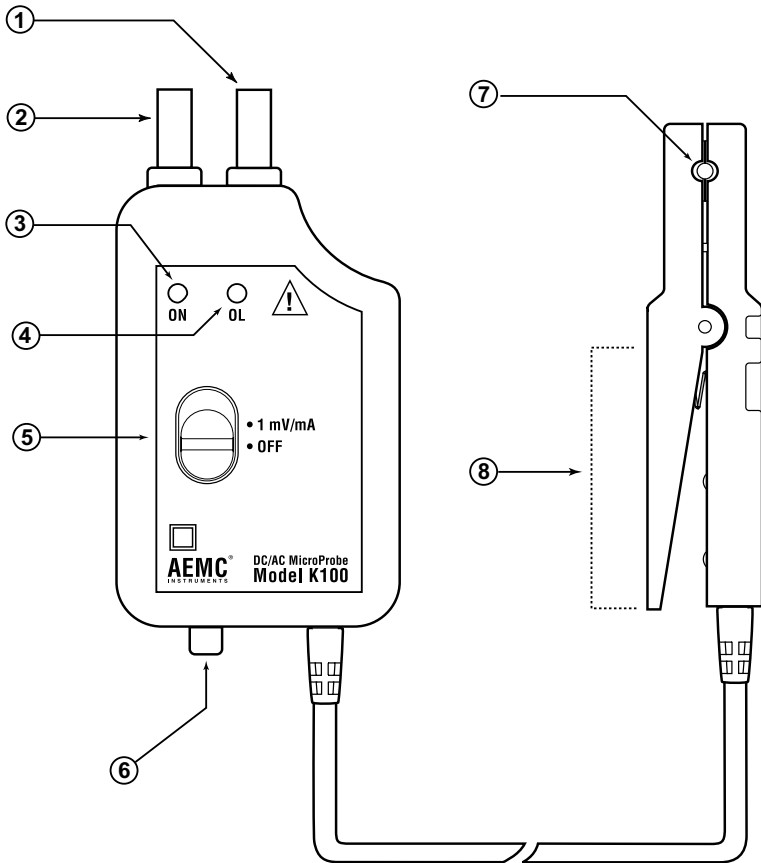

Figure 1

1. Positive: Red banana plug (+)
2. Negative: Black banana plug (-)
3. Power ON indicator (green LED)
4. OVERLOAD indicator (red LED)
5. Power switch
6. Zero adjust knob (push in and turn to zero)
7. Probe window aperture
8. Probe handle

2.3 Model K110 Features

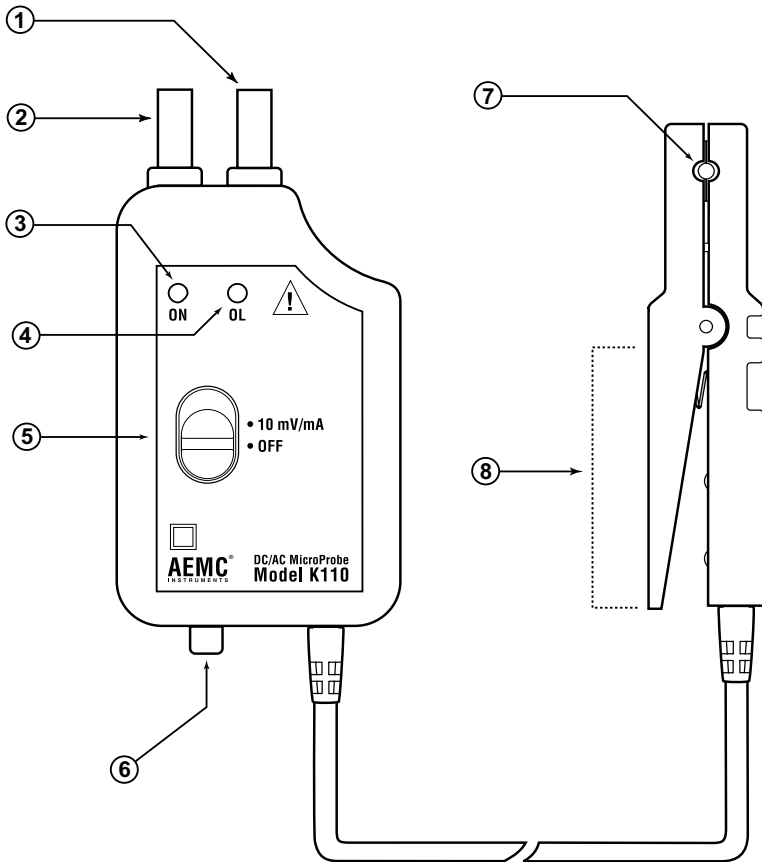

Figure 2

1. Positive: Red banana plug (+)
2. Negative: Black banana plug (-)
3. Power ON indicator (green LED)
4. OVERLOAD indicator (red LED)
5. Power switch
6. Zero adjust knob (push in and turn to zero)
7. Probe window aperture
8. Probe handle

SPECIFICATIONS

3.1 Electrical Specifications

Model K100

Current Range:0 to ± 4.5 A DC

0 to 3 Arms (sinusoidal)

Output (Vout): 1mV/mA**Resolution:**DC: 50 μ A typicalAC: 100 μ A typical**Accuracy:**DC: 1% reading $\pm 200\mu$ AAC: 2% reading $\pm 200\mu$ A**Output Noise:**< 100 μ V, DC to 3kHz**Frequency Response:**

DC to 2kHz (@ -3dB sine)

Zero Adjust: ± 25 mA**Rise Time:** < 200 μ S, 10% to 90% Vout**Fall Time:** < 200 μ S, 90% to 10% Vout**Output Impedance:** 200 Ω **Probe Inductance:** <1 μ H**Influence of Adjacent Conductor:** <50 μ A/A (K100); <100 μ A/A (K110)**Influence of Earth's Field:** <120 μ A, null to maximum**Overload LED (Red):** Indicates momentary or continuous overload**Power LED (Green):** Indicates power ON and good battery
LED (Green) ON between 6.5 to 10V**Power Source:** 9V alkaline, NEDA 1604, 6LR61 or IEC 6LF22
Battery life 20H approx. with alkaline battery

(Reference Conditions: 23°C \pm 3°, 20 to 75% RH; battery voltage 9V \pm 0.1V; earth's magnetic field < 40 A/m; absence of AC fields; input impedance of display device $\geq 1M\Omega/100$ pF; DC or sinusoidal AC current 45 to 65Hz.)

Model K110

Current Range:0 to ± 450 mA DC

0 to 300mA rms

Output (Vout): 10 mV/mA**Resolution:**DC: 50 μ A typical,AC: 100 μ A typical**Accuracy:**DC: 0.5% reading $\pm 150\mu$ AAC: 0.8% reading $\pm 200\mu$ A**Output Noise:**<100 μ V, DC to 3kHz**Frequency Response:**

DC to 1.5kHz (@ -3dB sine)

Zero Adjust: ± 25 mA

3.2 Environmental Specifications

Operating Temperature: -14° to 131°F (-10° to 55°C)

Storage Temperature: -40° to 176°F (-40° to 80°C)

Humidity: <95% @ ≤ 35°C, 75% @ 55°C

3.3 Mechanical Specifications

Dimensions (Probe): 4.4 x 0.6 x 1.0" (111 x 15 x 25mm)

Dimensions (Electronic Module): 4.9 x 2.5 x 1.1" (124 x 64 x 28mm)

Weight: 9 oz (250g)

Connectors: Two 4mm banana plugs; standard 3/4" (19mm) spacing

Maximum Conductor Diameter: 3/16", 0.180" (4.5mm)

Cable Length: 5 ft (1.5m)

3.4 Safety Specifications



Working Voltage:

EN61010-1, 300V CAT II

CE mark for Electromagnetic Compatibility.

Immunity (EN 50082.1), IEC 1000-4-3 aptitude criteria A:

DC: 15mV @ 0, AC (60Hz): 2dB from 10mA to 4.5A

Emmissivity (EN 50081.1): negligible

Drop Test: 1m per IEC 1010

Shocks: 100G per IEC 68-2-27

Vibrations: IEC 529

Protection Index: IP 40 per IEC 529

Electromagnetic Compatibility:

EN 50082-1 class A EN 50081-1

**All specifications are subject to change without notice.*

3.5 Typical Frequency Response

Model K100

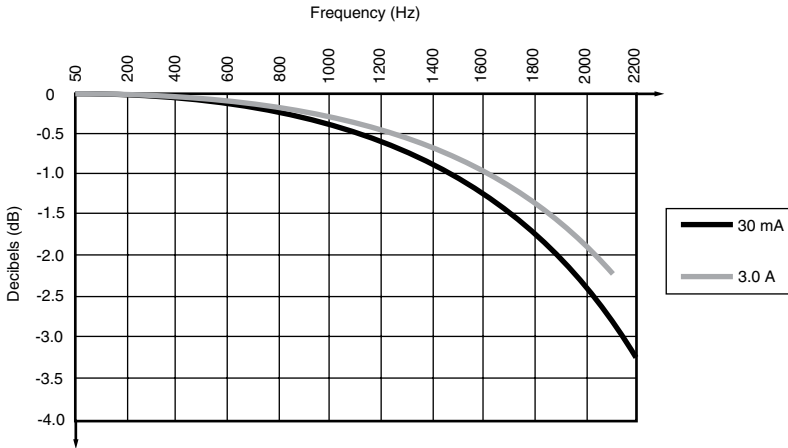

Figure 3

Model K110

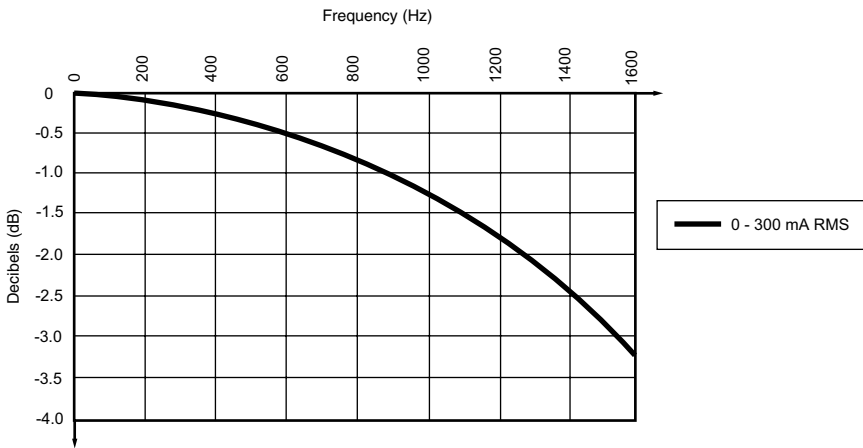

Figure 4

OPERATION

4.1 Making Measurements with the K100/K110

- Remove any conductor from within the probe jaws.
- Plug the electronic module into the displaying device (e.g., DMM, oscilloscope). Note the polarity of the module output banana plugs (red = positive [+], black = negative [-]).
- Select the appropriate range on displaying device (e.g., DMM, oscilloscope). Note that the module output is 1mV/mA for Model K100 and 10mV/A for model K110.
- Turn displaying device power ON. Turn on the Model K100/K110 (the green LED should be ON, and the red LED OFF).
- With the probe disconnected from test samples (no conductor in probe jaw window), adjust the zero control (push in the knob and turn) to read zero volts on the displaying device. In the unlikely event where the zero point is unobtainable, refer to *Residual Readings Following Severe Overloads* (§ 4.6) - the Model K100/K110 probe may be temporarily magnetized.
- Clamp the probe around the conductor to be tested. The displaying device should now display the measured conductor current. In DC, a positive reading indicates current flowing in the direction of the arrow on the probe. A negative reading indicates current flow in the opposite direction of the arrow.

4.2 Indicator Lights - Green and Red LEDs

- The Green LED indicates that the Model K100/K110 is ON and that the battery is good. The Green LED will not light under low battery conditions. Replace the 9V battery if the green LED is not lit.
- The Red LED indicates a momentary or continuous overload of the instrument. Readings taken while the Red LED is ON or FLASHING should be considered inaccurate. Momentary or continuous currents exceeding $\pm 4.7A$ for Model K100 and 470mA for Model K110, and dynamic currents with large step discontinuities will cause the red LED to turn ON.

4.3 Model K100 Operation Examples

DC Current Measurement Example (K100)

- Conductor carrying 20.0mADC in the direction of the arrow
- Voltmeter placed in DC Volts mode
- Voltmeter displays 20.0mV

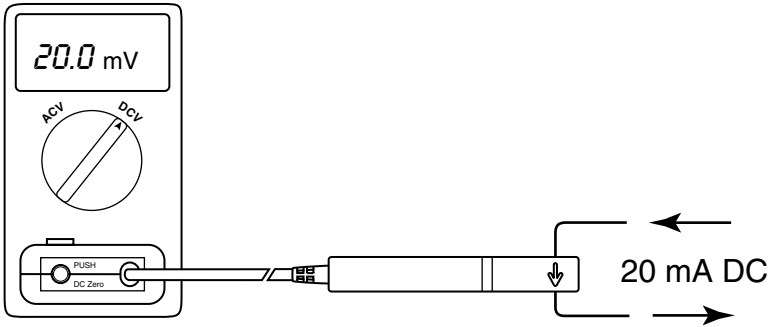

Figure 5

DC Current Measurement Example - Current Reversed (K100)

- Conductor carrying 20.0mADC in opposite direction of arrow
- Voltmeter placed in DC Volts mode
- Voltmeter displays -20.0mV

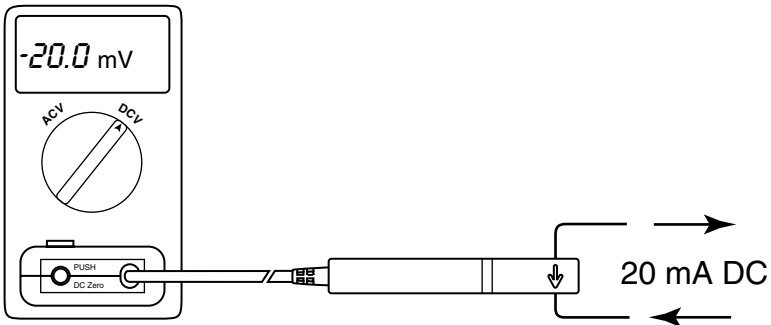

Figure 6

Two-Wire Sum-of-Currents Example (K100)

- Two conductors in probe aperture (note orientations)
- Voltmeter placed in DC Volts mode
- Voltmeter displays 18.0mV

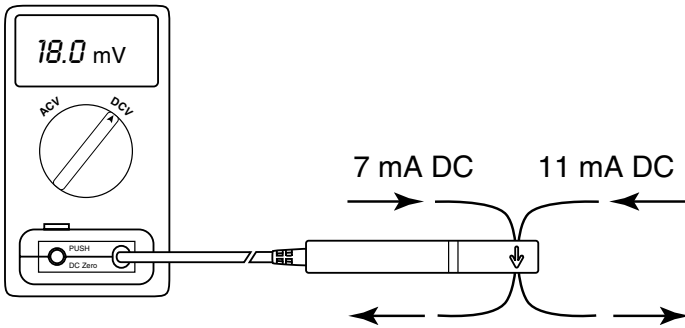

Figure 7

Two-Wire Current Differential Example (K100)

- Two conductors in probe aperture (note orientations)
- Voltmeter placed in DC Volts mode
- Voltmeter displays -4.0mV

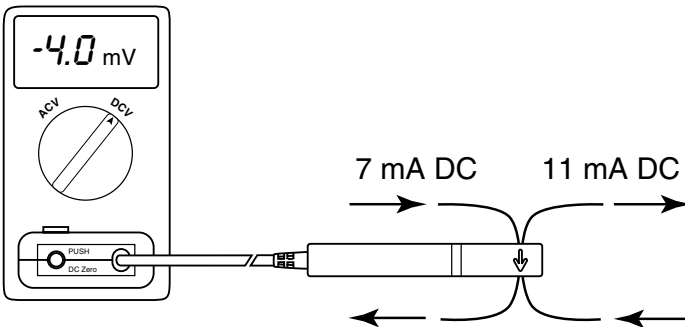

Figure 8

Oscilloscope Measurement Example (K100)

- Conductor carrying a 2A peak AC waveform
- Model K100 connected to oscilloscope

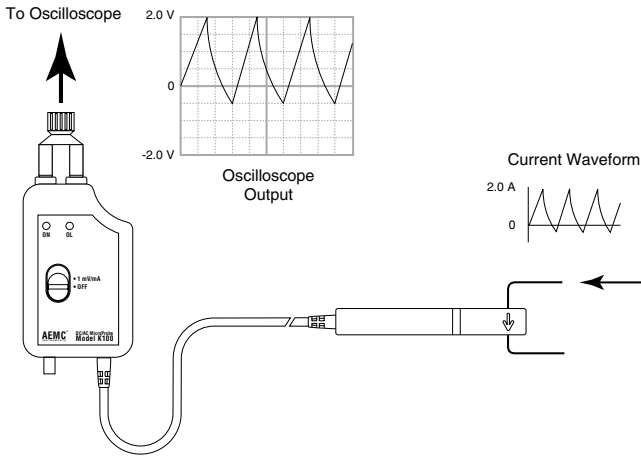

Figure 9

Maximum Step Discontinuity Example (K100)

- Conductor carrying non-sinusoidal AC
- Model K100 connected to oscilloscope
- Maximum allowable step-discontinuity 2A

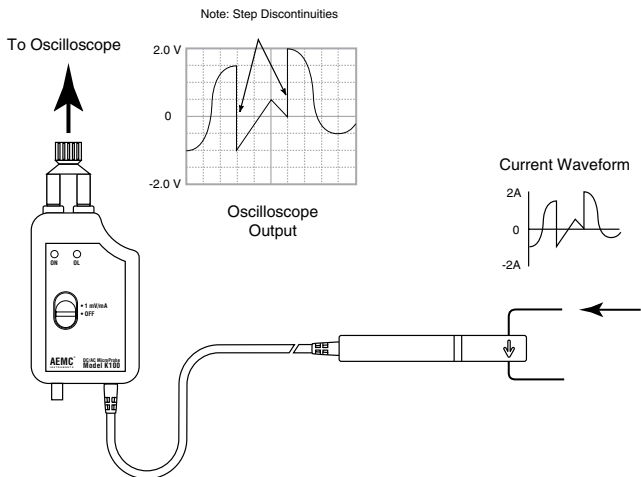

Figure 10

4.4 Model K110 Operation Examples

Measuring the DC Component of an (AC+DC) Waveform (K110)

- Conductor carrying 20.0mADC + 15.0mAAC
- Voltmeter placed in DC Volts mode
- Voltmeter displays 200.0mV

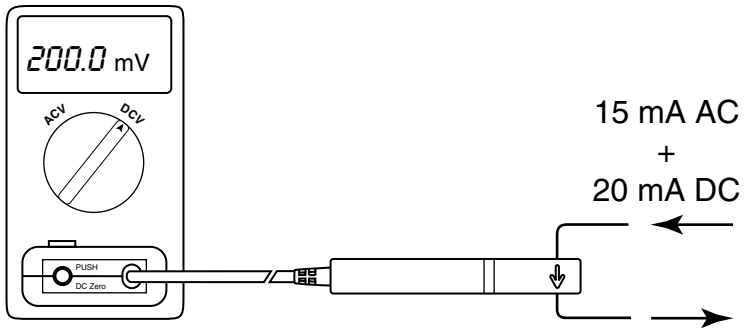

Figure 11

Measuring the AC Component of an (AC+DC) Waveform (K110)

- Conductor carrying 20.0mADC + 15.0mAAC
- Voltmeter placed in AC Volts mode
- Voltmeter displays 150.0mV

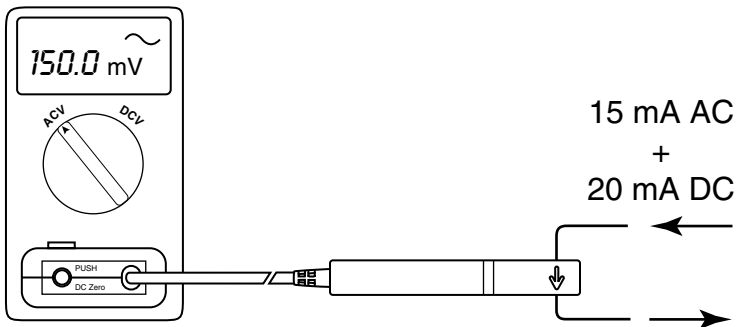

Figure 12

Oscilloscope Measurement Example (K110)

- Conductor carrying a 0.2A peak AC waveform
- Model K110 connected to oscilloscope

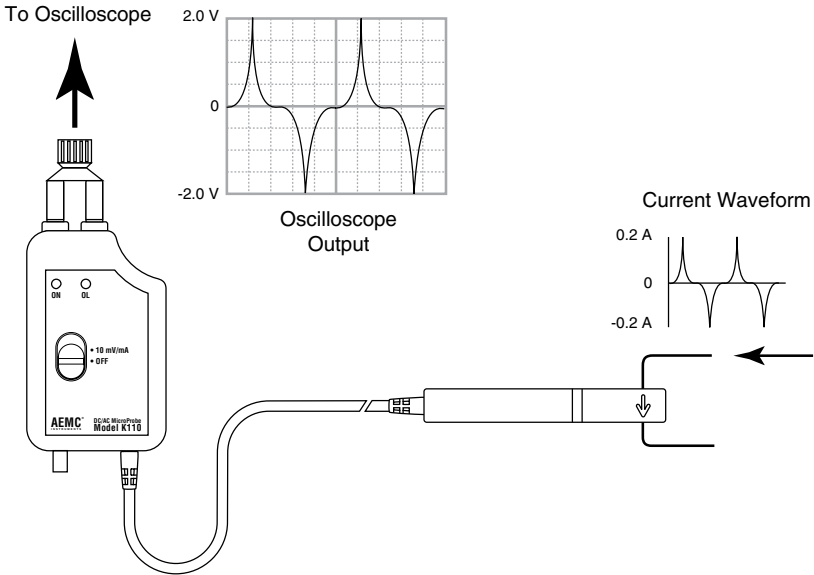

Figure 13

4.5 Tips For Making Precise Measurements

The Model K100/K110 is capable of making measurements of DC and low frequency currents over a wide range. Here are some key considerations for getting the most accuracy from your displaying instrument:

- When using the Model K100/K110 with a meter, it is important to select the range that provides the best resolution. Failure to do this may result in measurement errors. The examples shown on the next page use an ordinary 3-1/2 digit DMM with the Models K100 and K110, to measure 16.7mADC.

Model K100

Resolution: 10mV
Display Error: 19.8%

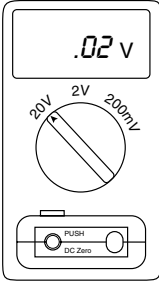

Resolution: 1mV
Display Error: 1.8%

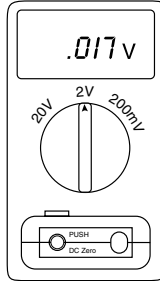

Resolution: 100 μV
Display Error: 0%

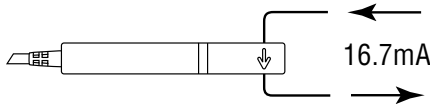
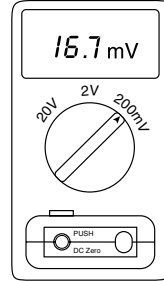
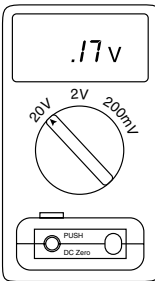

Figure 14

Model K110

Resolution: 10mV
Display Error: 1.8%



Resolution: 1mV
Display Error: 0%

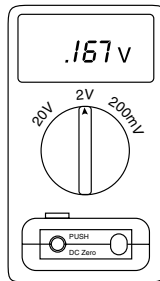

Resolution: 100 μV
Display Error: 0%

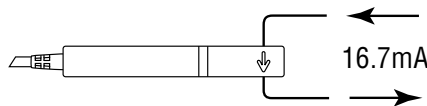
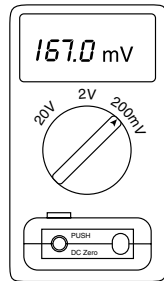

Figure 15

- Always zero the Model K100/K110 prior to making a measurement. See §4.1 for procedure.
- Make sure that probe jaw mating surfaces are free of dust and contamination. Contaminants cause air gaps between sensor halves, making the Model K100/K110 susceptible to external magnetic fields which can contribute to measurement errors. See §5.3 for cleaning procedure.
- Do not allow probe jaws to abruptly snap closed from the open state. This can lead to residual readings. If this happens, the Model K100/K110 will need to be rezeroed.
- Beware of short-circuit currents. Large in-rush currents (which can occur when power is first applied in a circuit) and large high-current transients may cause varying degrees of residual readings. If in doubt of a particular reading, remove the probe from the conductor under test and check to see that the display device returns zero. If not, it will be necessary to rezero the Model K100/K110.
- When using the Model K100/K110 to measure AC currents, keep in mind the maximum current ratings and the frequency response curves shown in the electrical specifications section. Dynamic currents that contain large step discontinuities and/or frequency constituents near or beyond the measurement passband are subject to measurement errors and waveform distortion (oscilloscope display). If the red LED comes on during measurement, the MicroProbe's output signal may be in error.

Many DVMs provide null (relative) measurement capability. A DVM placed in the null mode displays the difference between a stored null value and the input signal.

- You can use a DVM's null function in place of the external DC zero control to cancel any DC offset from the K100/K110. The DVM null function should be enabled with the probe removed from the conductor immediately before measurement.
- You can use a DVM's null function to display changes in measured current from a fixed (constant) level. In this application, the DVM null function is enabled with the probe connected to the conductor.

When making null (relative) measurements, the probe aperture current (not displayed current) must not exceed the maximum ratings set forth in the specifications section.

4.6 Residual Readings Following Severe Overloads

Large short-circuit and transient currents outside the operating range of the Model K100/K110 may cause large residual readings. In extreme cases, the Model K100/K110 will not zero. If this happens:

- Remove the probe from the test conductor.
- Open the probe and release, allowing the jaws to snap back. Repeat this step several times.
- Rezero the instrument before making successive measurements.

MAINTENANCE

5.1 **Warning**

Please make sure that you have already read and fully understand the **WARNING** section on page 2.

- To avoid electrical shock, do not attempt to perform any servicing unless you are qualified to do so.
- To avoid electrical shock and/or damage to the instrument, do not get water or other foreign agents into the case. Turn the Model K100/K110 OFF and disconnect the unit from all circuits before opening the case.

5.2 **Battery Installation**

Your Model K100/K110 has been shipped with a new 9V battery installed. To replace the battery:

- Remove probe from any conductor and place it away from any active conductors, circuitry, etc.
- Unplug electronic module from display device (e.g. DMM, oscilloscope).
- Remove the screws from the bottom cover of the electronic module.
- Replace battery with a new 9V alkaline type.
- Replace bottom cover and re-attach with screws.

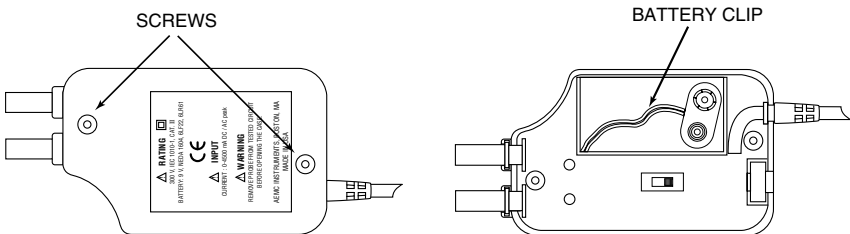

Figure 16

5.3 Cleaning

To ensure optimum performance, it is important to keep the probe jaw mating surfaces clean at all times. Failure to do so may result in increased earth's field susceptibility and overall errors in readings. The following is the recommended procedure for cleaning the probe sensor:

- (1) Apply a few drops of isopropyl alcohol to an ordinary sheet of white photocopy paper.
- (2) Open probe to expose the mating surfaces of the sensor and insert the sheet of paper into the jaws. Allow the jaws to close.
- (3) With the jaws closed, pull free the end of the paper through the jaws until it releases.
- (4) Repeat step (3) several times, using a new (dry) section of paper each time.
- (5) Open probe and inspect mating surfaces. They should be free of dust particles or any other contamination. Otherwise, repeat the cleaning process starting again at step (1).

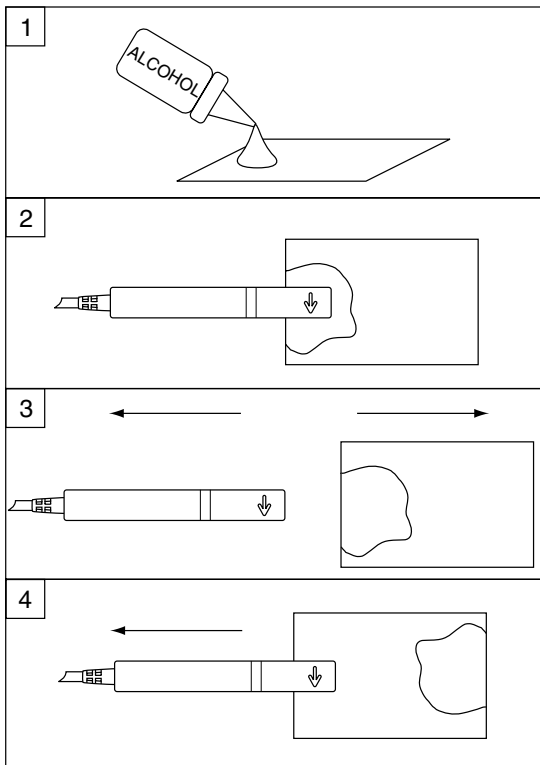

Figure 17

Repair and Calibration

To ensure that your instrument meets factory specifications, we recommend that it be scheduled back to our factory Service Center at one-year intervals for recalibration, or as required by other standards or internal procedures.

For instrument repair and calibration:

You must contact our Service Center for a Customer Service Authorization Number (CSA#). This will ensure that when your instrument arrives, it will be tracked and processed promptly. Please write the CSA# on the outside of the shipping container. If the instrument is returned for calibration, we need to know if you want a standard calibration, or a calibration traceable to N.I.S.T. (Includes calibration certificate plus recorded calibration data).

Ship To: Chauvin Arnoux®, Inc. d.b.a. AEMC® Instruments
15 Faraday Drive
Dover, NH 03820 USA
Phone: (800) 945-2362 (Ext. 360)
(603) 749-6434 (Ext. 360)
Fax: (603) 742-2346 or (603) 749-6309
E-mail: repair@aemc.com

(Or contact your authorized distributor)

Costs for repair, standard calibration, and calibration traceable to N.I.S.T. are available.

NOTE: You must obtain a CSA# before returning any instrument.

Technical and Sales Assistance

If you are experiencing any technical problems, or require any assistance with the proper operation or application of your instrument, please call, mail, fax or e-mail our technical support team:

Chauvin Arnoux®, Inc. d.b.a. AEMC® Instruments
200 Foxborough Boulevard
Foxborough, MA 02035 USA
Phone: (800) 343-1391
(508) 698-2115
Fax: (508) 698-2118
E-mail: techsupport@aemc.com
www.aemc.com

NOTE: Do not ship Instruments to our Foxborough, MA address.

Limited Warranty

The Models K100 and K110 are warranted to the owner for a period of two years from the date of original purchase against defects in manufacture. This limited warranty is given by AEMC® Instruments, not by the distributor from whom it was purchased. This warranty is void if the unit has been tampered with, abused or if the defect is related to service not performed by AEMC® Instruments.

Full warranty coverage and product registration is available on our website at www.aemc.com/warranty.html.

Please print the online Warranty Coverage Information for your records.

What AEMC® Instruments will do:

If a malfunction occurs within the warranty period, you may return the instrument to us for repair, provided we have your warranty registration information on file or a proof of purchase. AEMC® Instruments will, at its option, repair or replace the faulty material.

**REGISTER ONLINE AT:
www.aemc.com**

Warranty Repairs

What you must do to return an Instrument for Warranty Repair:

First, request a Customer Service Authorization Number (CSA#) by phone or by fax from our Service Department (see address below), then return the instrument along with the signed CSA Form. Please write the CSA# on the outside of the shipping container. Return the instrument, postage or shipment pre-paid to:

Ship To: Chauvin Arnoux®, Inc. d.b.a. AEMC® Instruments
15 Faraday Drive • Dover, NH 03820 USA
Phone: (800) 945-2362 (Ext. 360)
(603) 749-6434 (Ext. 360)
Fax: (603) 742-2346 or (603) 749-6309
E-mail: repair@aemc.com

Caution: To protect yourself against in-transit loss, we recommend you insure your returned material.

NOTE: You must obtain a CSA# before returning any instrument.

Notes:



09/17

99-MAN 100091 v14