

AC Current Probe Model MN185

User Manual

DESCRIPTION

The MN185 (Catalog #100.185) is a high accuracy current probe for tight areas such as crowded wiring. Extends DMM AC measurements to 120A AC.

WARNING

These safety warnings are provided to ensure the safety of personnel and proper operation of the instrument.

- Read the instruction manual completely and follow all the safety information before attempting to use or service this instrument.
- Use caution on any circuit: Potentially high voltages and currents may be present and may pose a shock hazard.
- Read the safety specifications section prior to using the current probe. Never exceed the maximum voltage ratings given.
- Safety is the responsibility of the operator.
- ALWAYS connect the current probe to the display device before clamping the probe onto the sample being tested.
- ALWAYS inspect the instrument, probe, probe cable, and output terminals prior to use. Replace any defective parts immediately.
- NEVER use the current probe on electrical conductors rated above 250V. Use extreme caution when clamping around bare conductors or bus bars.

INTERNATIONAL ELECTRICAL SYMBOLS



This symbol signifies that the current probe is protected by double or reinforced insulation. Use only factory specified replacement parts when servicing the instrument.



This symbol signifies CAUTION! and requests that the user refer to the user manual before using the instrument.



This is a type A current sensor. This symbol signifies that application around and removal from HAZARDOUS LIVE conductors is permitted.

RECEIVING YOUR SHIPMENT

Upon receiving your shipment, make sure that the contents are consistent with the packing list. Notify your distributor of any missing items. If the equipment appears to be damaged, file a claim immediately with the carrier and notify your distributor at once, giving a detailed description of any damage.

INSTRUMENT COMPATIBILITY

The Model MN185 is compatible with any ammeter, multimeter, or other current measuring instruments with an input impedance of less than 5Ω. To achieve the stated accuracy, use the MN185 with an ammeter having an accuracy of 0.75% or better.

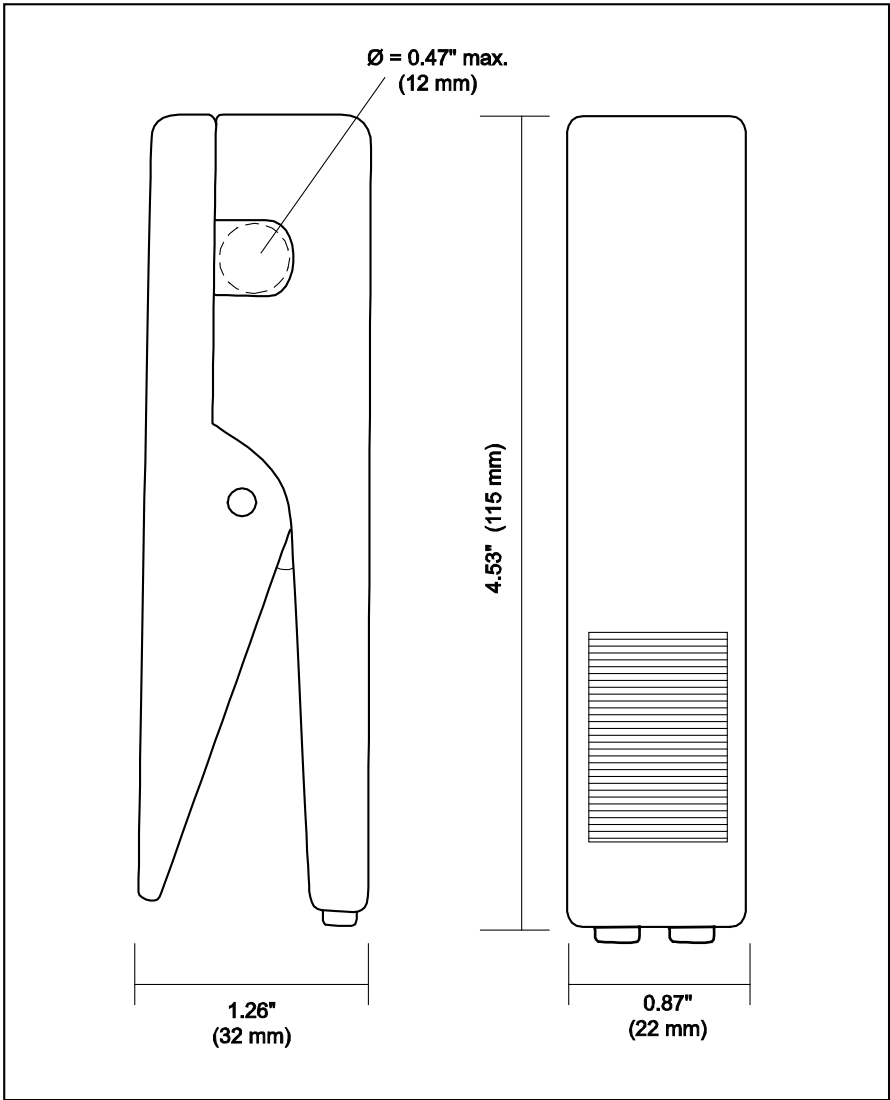

ELECTRICAL SPECIFICATIONS

Current Range:

50mA to 120A AC, continuous

Output Signal:

1mA AC / A AC (120mA @ 120A)

Accuracy and Phase Shift*:

Accuracy:

50mA to 100A: 1% ± 0.01A
(with non-inductive load)

100A to 120A: 1.5% ± 0.01A

Phase Shift:

≤ 3.5° from 1 to 100A, 50 to 60Hz

(*Reference conditions: 23°C ± 3°K, 20 to 85% RH, external magnetic field < 40A/m, no DC component, no external current carrying conductor, test sample centered.)
Load impedance 1Ω.

Overload:

170A continuously

Frequency Range:

30Hz to 10kHz

Load Impedance:

5Ω max

Working Voltage:

250V AC

Common Mode Voltage:

30V AC

MECHANICAL SPECIFICATIONS**Operating Temperature:**

-13° to 122°F (-25° to 50°C)

Storage Temperature:

-40° to 176°F (-40° to 80°C)

Temperature Influence:

< 0.2% per 10° K

Maximum Conductor Size:

0.47" Ø max. (12mm)

Dimensions:

1.26 x 4.53 x 0.87"
(32 x 115 x 22mm)

Weight: 5.6 oz (160g)**Colors:**

Dark gray handles with red cover

Polycarbonate Material:

Handle: 10% Fiberglass charged polycarbonate UL 94 V0

Output:

Two standard safety banana jacks (4mm)

SAFETY SPECIFICATIONS**Electrical:**

3kV 50/60 Hz dielectric

30V max common mode between output and ground

ORDERING INFORMATION

AC Current Probe MN185...Cat #100.185

Accessories:

Lead - Set of 2, 3 ft color-coded non-safety leads **Cat #1007.41**

OPERATION

Making Measurements with the AC Current Probe Model MN185

- Connect the terminals to the 200mA range of your DMM or instrument. The MN185 has a ratio of 1000:1. This means that for 100A AC in the conductor around which the probe is clamped, 100mA AC will come out of the probe leads to your DMM or instrument. The output is 1mA AC per Amp. Select the range on your DMM or instrument which best corresponds to the measured current. If the magnitude is unknown, start with the highest range (200mA AC) then work down until the appropriate range and resolution is reached. Clamp the probe around the conductor. Take the reading on the meter and multiply it by 1000 to obtain the measured current (e.g., 59mA reading: $59 \times 1000 = 59,000\text{mA}$ or 59A).
- For best accuracy, avoid if possible, the proximity of other conductors which may create noise.

Tips for Making Precise Measurements

- When using a current probe with a meter, it is important to select the range that provides the best resolution. Failure to do this may result in measurement errors.
- Make sure that probe jaw mating surfaces are free of dust and contamination. Contaminants cause air gaps between the jaws, increasing the phase shift between primary and secondary. It is very critical for power measurement.

MAINTENANCE

Warning:

- For maintenance use only original factory replacement parts.
- To avoid electrical shock, do not attempt to perform any servicing unless you are qualified to do so.
- To avoid electrical shock and/or damage to the instrument, do not get water or other foreign agents into the probe.

Cleaning: To ensure optimum performance, it is important to keep the probe jaw mating surfaces clean at all times. Failure to do so may result in error in readings. To clean the probe jaws, use very fine sand paper (fine 600) to avoid scratching the jaw, then gently clean with a soft oiled cloth.

REPAIR AND CALIBRATION

You must contact our Service Center for a Customer Service Authorization number (CSA#). This will ensure that when your instrument arrives, it will be tracked and processed promptly. Please write the CSA# on the outside of the shipping container.

Chauvin Arnoux[®], Inc. d.b.a. AEMC[®] Instruments
15 Faraday Drive • Dover, NH 03820 USA
(800) 945-2362 (Ext. 360) • (603) 749-6434 (Ext. 360) • repair@aemc.com

(Or contact your authorized distributor)

NOTE: All customers must obtain a CSA# before returning any instrument.

TECHNICAL AND SALES ASSISTANCE

If you are experiencing any technical problems, or require any assistance with the proper use or application of this instrument, please contact our technical hotline:

(800) 343-1391 • (508) 698-2115 • techsupport@aemc.com

LIMITED WARRANTY

The current probe is warranted to the owner for a period of two years from the date of original purchase against defects in manufacture. This limited warranty is given by AEMC[®] Instruments, not by the distributor from whom it was purchased. This warranty is void if the unit has been tampered with, abused or if the defect is related to service not performed by AEMC[®] Instruments.

Full warranty coverage and product registration is available on our website at:
www.aemc.com/warranty.html.

Please print the online Warranty Coverage Information for your records.