

ARES 6



ARES 6 USER'S GUIDE (REV. 3, JUNE 2015)

u s e r ' s g u i d e

Important Export Restrictions! Commodities, products, technologies and services contained in this manual are subject to one or more of the export control laws and regulations of the U.S. Government and they fall under the control jurisdiction of either the US Department of State or the US BIS-Department of Commerce. It is unlawful and strictly prohibited to export, or attempt to export or otherwise transfer or sell any hardware or technical data or furnish any service to any foreign person, whether abroad or in the United States, for which a license or written approval of the U.S. Government is required, without first obtaining the required license or written approval from the Department of the U.S. Government having jurisdiction. Diversion contrary to U.S. law is prohibited.



**AMERICAN
TECHNOLOGIES
NETWORK
CORP.**

Register your product warranty online at www.atncorp.com/warranty

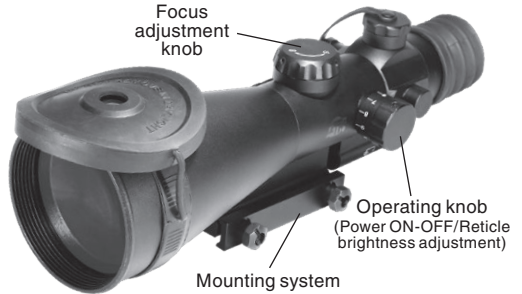
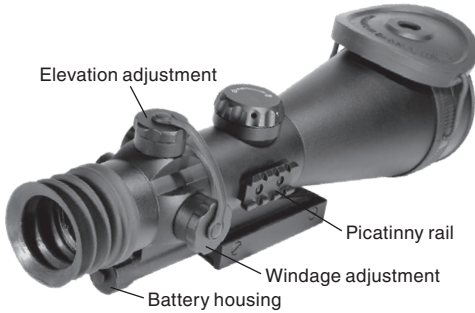

FEATURES

- Superior quality Multi-coated all-glass optics
- Precision windage and elevation adjustments
- “RED ON GREEN” reticle system with 1/6 MOA adjustment
- Automatic brightness control (ABC) for tube protection
- One-knob operation
- Illuminated center red reticle for optimal contrast against a dark or light target
- Mounts to standard weaver rails
- Use 1 AA type battery
- Limited Two-Year Warranty

APPLICATION

The ATN ARES series is the latest offering in the ATN night vision weapon sight line.

The ARES 6 series provide the user with a rugged, easy to use and accurate night vision weapon sight. Fast infra-red sensitive optics coupled with quality image tubes provide high resolution clear images for outstanding target acquisition and aiming capabilities.

Rugged, ease of use and accurate are just a few of the features these scopes have to offer. Available with a wide array of Image Intensifier Tube configurations to choose from they set out to satisfy a variety of budgets, requirements and specifications.

Designed for optimal performance for both professional and sporting uses the ARES 6 is the next generation of ATN scopes.

CAUTION:

THIS PRODUCT CONTAINS NATURAL RUBBER LATEX WHICH MAY CAUSE ALLERGIC REACTIONS

The information in this manual furnished for information use only, is subject to change without notice, is not to be construed as a commitment by ATN Corp.

ATN Corp. assumes no responsibility or liability for any errors or inaccuracies that may appear in this book.

©2015 ATN Corp. All right reserved.

SPECIFICATIONS

Magnification	6X
FOV	5°
Range of focus	10 m to infinity
Reticle	Red On Green
Windage & elevation adjustments	1/6 MOA
IR illuminator	Digital 850 mW (detachable)
Power Supply	One 1.5 V AA size battery
Battery life	30 hours
Operating Temperature	-40°C to +50°C
Storage Temperature	-50°C to +70°C
Dimensions	288 x 94 x 90 mm/11.5 x 3.75 x 3.6"
Weight	1.5 kg/3.3 lb
Diopter adjustment	+6/-4

* ATN reserves the right to change the above specifications at any time without notice

PREPARATION FOR OPERATION

Before getting started make sure to follow these steps:

- Install the battery into its housing with the polarity order shown on the main body of the unit.
- Switch on the scope with the protective lens cover still attached to the lens.
- Make sure that the green luminance of the light intensifier tube is present.
- Observe the scene, and adjust the diopter and/or lens for optimal image clarity.
- You may now enter a dark environment or simply shut the lights off in order to darken the room.
- Next, remove the lens cap/daylight filter.
- Finally, you may want to turn the infra red (IR) illuminator on. Notice the ability of the scope to see in total darkness with the aid of the IR illuminator.



OPERATING

MOUNTING

1. Slightly loosen the fixing screws on the 7/8" weaver mount built into the scope.
2. Place the scope on the weaver rail of the fire arm.
3. Tighten the fixing screws.

NOTE: Fixing screws may need to be tightened after continuous shooting.

MOUNTING SYSTEM

The ATN Night Vision Riflescopes Mounting System allows to change the position of the rifle-scope flexibly on the weapon in relation to a shooter in combination with the fixed positions already available on the weaver rail. For this purpose in the base of the mounting bracket there is a rail with a fixing projection. There are two grooves in the mounting bracket for mounting this rail. Besides it is possible to change the position of the riflescope additionally by 1/3 of inch. For doing this one needs to about-face the rail.

To change the position of the riflescope on the weaver rail additionally follow the steps mentioned below:

1. Unscrew the two screws, which attach the rail to the mounting bracket.
2. Take the rail out of the groove.
3. About-face the rail in case of necessity.
4. Place the rail into another groove.
5. Fix the rail with the two screws.

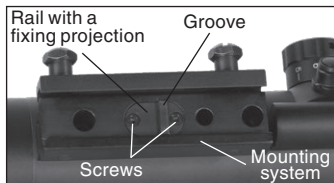

NOTE: If the rail does not come out easily, tighten one of the removed screws into the threaded aperture in the middle of the fixing projection of the rail. Rotate this screw, which will in turn push the rail out from the groove.

CONTROL

The ARES 6 has a simple and easy to operate one-knob control and adjustment.

To turn riflescope on rotate the operation knob from position marked "0".

To turn riflescope off rotate the operation knob to position marked "0".

After turning scope on, you may adjust the reticle's brightness by rotating the operation knob from position marked "1" to position "9". Position "1" corresponds to the minimal brightness, the position "9" corresponds to the maximal brightness of reticle's glow.

Adjustment could be easily seen if you look through the scope while adjustment.

FOCUSING

To focus the scope you need to adjust the diopter first. Simply turn the diopter clockwise until it stops. Then concentrate on any object and slowly turn the diopter back counter clockwise until the grain in the image is sharp.

Your scope has ability to focus either long range or short.

Focus the front lens by rotating the knob until the image and the grain are both sharp. When you are in the low-light conditions and the daylight filter is off you may focus the front lens to receive a sharp image, the diopter should not be adjusted.

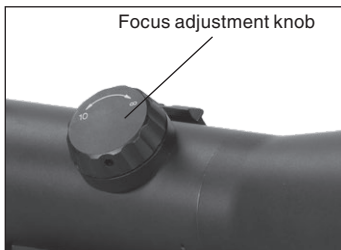

NOTE: The front lens should be readjusted for viewing objects at different distances.

OPERATION EXTENDIBILITY

There is Picatinny rail on the body of the scope for additional lighting, laser and other mission critical tools.

IR ILLUMINATION

Infra-red (IR) illuminators are common for night vision technology. The IR light greatly enhances the performance of your ARES 6 scope, while remaining almost totally invisible to the naked eye. In dark environment, power up the ATN ARES 6. Now, find a scene and examine it without the IR on then with IR powered up. Note the difference in illumination. It is important to remember that the IR illuminator is simply an infra red light source, and like any light source it may lose its effectiveness over a great distance.

To fix the IR illuminator to the riflescope use the picatinny rail of the scope.

The IR illuminator control buttons are located on its side. To switch the Digital IR illuminator on/off press "+" and "-" buttons simultaneously. When the IR illuminator is switched on you can see the green LED lit. By pushing the buttons "+" and "-" you may adjust the IR brightness.

The IR beam is focusable to change the field of coverage. To change the beam width slightly turn the IR lens.

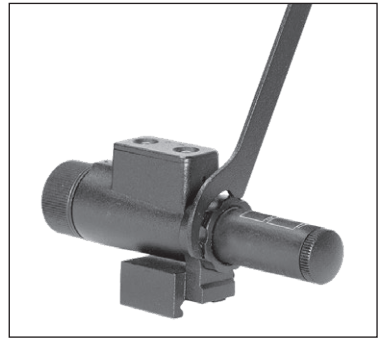
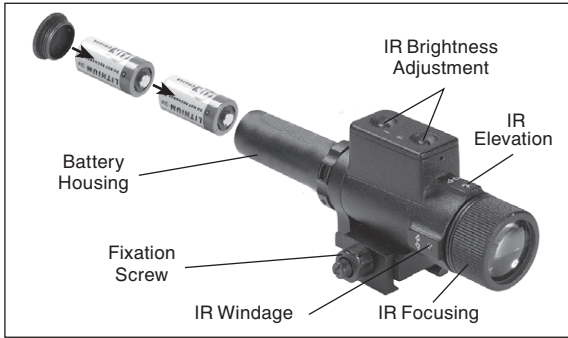

You could change the IR control panel fitting your needs. The wrench included into the set should be used for weakening the fixing nut located on the IR. Rotate the IR placing it in the most convenient position. Tighten the nut with the wrench to fix the new position.

RETICLE

The ARES 4 reticle gives a clear aiming point, even when hard-to-see targets blends into the background. Thin posts and center crosshairs cover a minimum of the target and allow for less target coverage, making precision shots on small targets easy.

Lit center section of crosshairs have an adjustable brightness to lead your eye directly to the center and aiming position. The result is fast precision target acquisition.

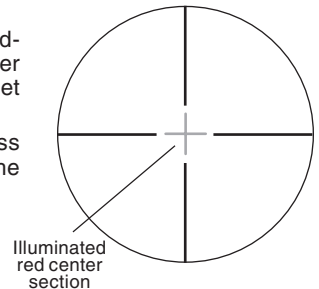

WINDAGE AND ELEVATION

The vertical and horizontal adjustments for the ARES 6 can be achieved by turning the elevation and windage adjustment mechanisms (remove dust caps first). Each click equals 1/6 MOA. When reaching the maximum range of rotation do not use force.

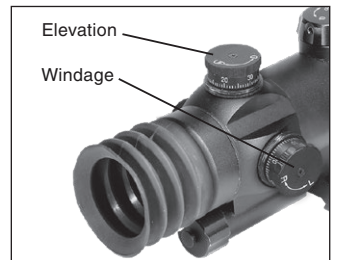

CLEANING THE OPTIC SURFACES

You may need to clean the optic surfaces of the riflescope from time to time in order to guarantee top performance. When you receive your riflescope you should check for dust on the optic surfaces of the unit.

CAUTION: Use only Photographic lens cleaning tissue on these surfaces. Be careful not to scratch or smudge any of these surfaces. When using compressed air to blow dust away, make sure to avoid inverting the can while spraying. This can cause frozen propellant to exit the can, which can cause serious problems with the glass and phosphor screen.

WARNINGS AND CAUTIONS

- Always remember to turn off the ARES 6 scope when it is not in use. If you do not plan on using your scope for a period of more than 10 days, you should remove the batteries.
- Keep lens cap on when not in use.
- Avoid contact with dust, steam, and gas.
- The scope is not harmful to the user or the environment.
- Do not disassemble: **it will void your warranty.**
- Evaluate the scopes function by looking through it in a lit environment with the lens cap put on. Never use in daylight without the daylight filter lens cap on. Do not surpass ten minutes of testing.
- Never point the scope at a bright light source.
- Adverse atmospheric conditions such as fog, smog, or haze and a lack of ambient light (moon or starlight) may diminish the effective viewing distance. All technical data for this unit was compiled in a controlled environment.
- This product contains natural rubber latex which may cause allergic reactions.

TROUBLESHOOTING

Q: Flashes, flickers, or clicking occur while operating

S: If it occurs within the first five minutes of inserting new batteries, it is normal and the device will resume normal operation soon thereafter. If it occurs for more than 10 minutes, contact your dealer or other authorized service representative for service instructions.

Q: Dark spots on screen.

S: This may be dust on the lens, please clean according to instructions. They may also be Cosmetic blemishes in the intensifier tube which are a by-product of the manufacturing process. This is normal and will not affect the life or performance of the unit.

Q: Image not clear.

S: Adjust diopter ring. If problem persists, increase viewing distance

Q: Fixed-pattern noise in a honeycomb shape.

S: Usually a cosmetic blemish characterized by a faint honeycomb-type pattern. This usually occurs when viewing very bright lights.

Q: A pattern of dark thin lines which look like chicken wire.

S: Turn on illuminator, if purchased. If illuminator doesn't brighten image, replace batteries. If problem persists, contact ATN for service instructions.

2 YEAR PRODUCT WARRANTY

This product is guaranteed to be free from manufacturing defects in material and workmanship under normal use for a period of 2 (two) years from the date of purchase. In the event a defect that is covered by the foregoing warranty occurs during the applicable period stated above, ATN, at its option, will either repair or replace the product, and such action on the part of ATN shall be the full extent of ATN's liability, and the Customer's sole and exclusive remedy. This warranty does not cover a product (a) used in other than its normal and customary manner; (b) subjected to misuse; (c) subjected to alterations, modifications or repairs by the Customer or by any party other than ATN without prior written consent of ATN; (d) special order or "close-out" merchandise or merchandise sold "as-is" by either ATN or the ATN dealer; or (e) merchandise that has been discontinued by the manufacturer and either parts or replacement units are not available due to reasons beyond the control of ATN. ATN shall not be responsible for any defects or damage that in ATN's opinion is a result from the mishandling, abuse, misuse, improper storage or improper operation, including use in conjunction with equipment which is electrically or mechanically incompatible with or of inferior quality to the product, as well as failure to maintain the environmental conditions specified by the manufacturer. **CUSTOMER IS HEREBY NOTIFIED THAT OPERATION OF THE EQUIPMENT DURING DAYLIGHT HOURS OR UNDER ANY EXCESSIVE LIGHT CONDITIONS MAY PERMANENTLY DAMAGE THE INTERNAL COMPONENTS OF THE UNIT AND SAID DAMAGE WILL NOT BE COVERED UNDER THIS WARRANTY.** This warranty is extended only to the original purchaser. Any breach of this warranty shall be waived unless the customer notifies ATN at the address noted below within the applicable warranty period.

The customer understands and agrees that except for the foregoing warranty, no other warranties written or oral, statutory, expressed or implied, including any implied warranty of merchantability or fitness for a particular purpose, shall apply to the product. All such implied warranties are hereby and expressly disclaimed.

LIMITATION OF LIABILITY

ATN will not be liable for any claims, actions, suits, proceedings, costs, expenses, damages or liabilities arising out of the use of this product. Operation and use of the product are the sole responsibility of the Customer. ATN's sole undertaking is limited to providing the products and services outlined herein in accordance with the terms and conditions of this Agreement. The provision of products sold and services performed by ATN to the Customer shall not be interpreted, construed, or regarded, either expressly or implied, as being for the benefit of or creating any obligation toward any third party of legal entity outside ATN and the Customer; ATN's obligations under this Agreement extend solely to the Customer. **ATN's liability hereunder for damages, regardless of the form or action, shall not exceed the fees or other charges paid to ATN by the customer or customer's dealer. ATN shall not, in any event, be liable for special, indirect, incidental, or consequential damages, including, but not limited to, lost income, lost revenue, or lost profit, whether such damages were foreseeable or not at the time of purchase, and whether or not such damages arise out of a breach of warranty, a breach of agreement, negligence, strict liability or any other theory of liability.**

PRODUCT WARRANTY REGISTRATION

In order to validate the warranty on your product, ATN must receive a completed Product Warranty Registration Card for each unit or complete warranty registration on our website at www.atncorp.com. Please complete the included form and immediately mail it to our Service Center: ATN Corporation, 1341 San Mateo Avenue, South San Francisco, CA 94080.

OBTAINING WARRANTY SERVICE

To obtain warranty service on your unit, End-user must notify ATN service department by calling **800-910-2862** or **650-989-5100** or via e-mail **service@atncorp.com** to receive a Return Merchandise Authorization number (RMA).

When returning please take or send the product, postage paid, with a copy of your sales receipt to our service center, ATN Corporation at the address noted above. All merchandise must be fully insured with the correct postage; ATN will not be responsible for improper postage or, missing or damaged merchandise during shipment.

When sending product back, please clearly mark the RMA# on the outside of the shipping box. Please include a letter that indicates your RMA#, Name, Return Address, reason for service return. Contact information such as valid telephone numbers and/or e-mail address and proof of purchases that will help us to establish the valid start date of the warranty. Product merchandise returns that do not have an RMA listed may be refused or a significant delay in processing may occur.

Estimated Warranty service time is 10-20 business days. End-user/customer is responsible for postage to ATN for warranty service. ATN will cover return postage/shipping to continental USA end-users/customers after warranty repair only if product is covered by aforementioned warranty. ATN will return product after warranty service by domestic UPS ground and/or domestic mail. Any other requested, required or international shipping method the postage/shipping fee will be the responsibility of the end-user/customer.

18062015



For customer service and technical support, please contact

American Technologies Network Corp.

1341 San Mateo Avenue, South San Francisco, CA 94080
phone: 800-910-2862, 650-989-5100; fax: 650-875-0129

www.atncorp.com