

Date \_\_\_\_\_  
 AVFI Sales REP \_\_\_\_\_  
 Customer Signature \_\_\_\_\_

Quote No. \_\_\_\_\_  
 Customer No. \_\_\_\_\_  
 AVFI No. \_\_\_\_\_

Office Use Only

To generate your order form, please refer to the information provided below to insert the alphabetic and/or numeric code in the respective category boxes. Please note that without this filled out Order Form, your purchase **cannot** be processed.

1 Product Model	2 Top Option	3 Finish	4 Chargeable Accessories (One Code Per Box)	5 Custom Cutouts
<b>PD51</b>				

### 1 Product Model

**Optional Tops**



Code **PD51**  
(Standard Configuration)

5101TP-L (Left Overhang)



5101TP-R (Right Overhang)



5102TP (Double Overhang)



### 2 Choose Product Finish

**Standard Finishes** (Ships within 1-15 business days)



Code **CJT**  
(Crossfire Java)





Code **ELT**  
(Elegance)





Code **EBT**  
(Ebony)

**Optional Finishes** (Ships within 20 business days)

 **FMT**

 **HCT**

 **RCT**

 **CLT**

 **ART**

 **BRT**

 **CWT**

 **BAT**

 **SGT**

Comments (Please use this section to provide additional information)

---



---



---



---

### Notes

**CAD Drawings/Symbols**  
 CAD drawings are available by request at sales@vegroun.net

**Custom Cutouts**  
 Estimated lead time within 20 business days from receipt of P.O. and signed drawings.

**Customizations**  
 Modifications to design such as shape and/or size variations have to be quoted on a per case basis and are applicable for quantities of 10+ only.

### 2 Choose Top Option (Extra Charges Apply)

Code **C7** 5101TP-L (58" Left Overhang Worktop)  
 Code **C8** 5101TP-R (58" Right Overhang Worktop)  
 Code **C9** 5102TP (58" Double Overhang Worktop)

### 3 Chargeable Accessories (Check all that apply)

Code **O0** No Accessories \_\_\_\_\_ Qty \_\_\_\_\_  
 Code **A4** SH-FL-51 Folding Side Shelf Kit..... Qty \_\_\_\_\_  
 Code **B1** 9031-1 1U Utility Metal Shelf ..... Qty \_\_\_\_\_  
 Code **B2** 9031-2 2U Utility Metal Shelf ..... Qty \_\_\_\_\_  
 Code **B3** 9031-3 3U Utility Metal Shelf ..... Qty \_\_\_\_\_  
 Code **B4** 9041 Sliding Metal Shelf (Rear Rack Rail required) ..... Qty \_\_\_\_\_  
 Code **B5** 9052-2 2U Sliding Metal Drawer ..... Qty \_\_\_\_\_  
 Code **B6** 9052-3 3U Sliding Metal Drawer ..... Qty \_\_\_\_\_  
 \* Code **D1** MIC-18 MX418 S/C Microphone ..... Qty \_\_\_\_\_  
 \* Code **D2** LIGHT-18 Gooseneck Light ..... Qty \_\_\_\_\_  
 \* Code **D3** FM3 Timer/Clock ..... Qty \_\_\_\_\_  
 Code **E1** PB 6 Outlet Power Bar ..... Qty \_\_\_\_\_  
 \* Code **E3** CUB3 Round Cable Well ..... Qty \_\_\_\_\_  
 \* Code **E4** SF-PB3 3 Outlet Power Bar ..... Qty \_\_\_\_\_  
 \* Code **E5** CUB5 Black Round Cable Well ..... Qty \_\_\_\_\_  
 \* Code **E6** CUB5 Silver Round Cable Well ..... Qty \_\_\_\_\_  
 \* Code **E7** PC-PATCH Power-Data Module ..... Qty \_\_\_\_\_  
 \* Code **E8** CUB8 Table Top Cable Well ..... Qty \_\_\_\_\_  
 \* Code **EA** CUB4S Silver Power Panel ..... Qty \_\_\_\_\_  
 \* Code **EB** CUB4B Black Power Panel ..... Qty \_\_\_\_\_  
 \$\* Code **EC** CHGQIW Wireless Charging Station White ..... Qty \_\_\_\_\_  
 \$\* Code **EF** CHGQIB Wireless Charging Station Black ..... Qty \_\_\_\_\_  
 \*\* Code **ED** CHGQI-DNGL Dongle Lightning ..... Qty \_\_\_\_\_  
 Code **F9** 5104TP Bridge Top ..... Qty \_\_\_\_\_  
 Code **FA** 5104DE Desk End (ADA Compliant) ..... Qty \_\_\_\_\_  
 Code **H6** RR14 14U Rack Rail Kit (Rear) ..... Qty \_\_\_\_\_  
 Code **J1** 9107 Lacing Bar ..... Qty \_\_\_\_\_  
 Code **J5** DIR9200-12 12U Rack Module ..... Qty \_\_\_\_\_  
 Code **K1** C900S Single Monitor Arm ..... Qty \_\_\_\_\_  
 Code **K3** PLM1022 Monitor Mount ..... Qty \_\_\_\_\_  
 Code **K4** MM1232 Monitor Mount ..... Qty \_\_\_\_\_  
 Code **M5** MCB1925 Monitor/Camera Bracket ..... Qty \_\_\_\_\_  
 Code **Q1** LEV4A4X 4x Levelers for Non-Mobile Applications ..... Qty \_\_\_\_\_

\* Cutout Required (Extra Charges will apply)  
 \*\* Requires CHGQIW/B accessory     \$ Only on Flat Cutout

Custom Cutout Option on Page 2

Please indicate custom cutout location on the drawing(s) below

5 Custom Cutout Option (Extra charges will apply)

**PD51 - Standard Configuration**

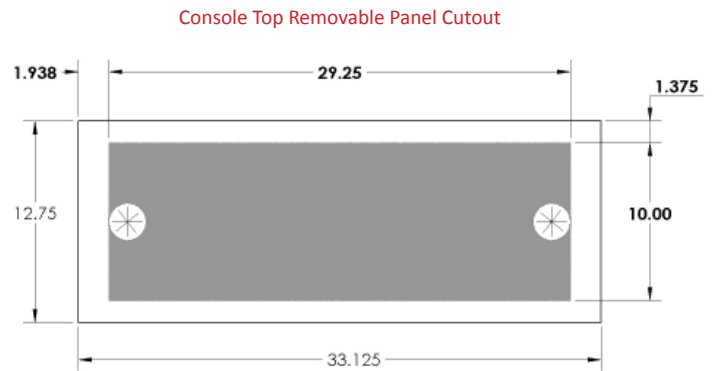
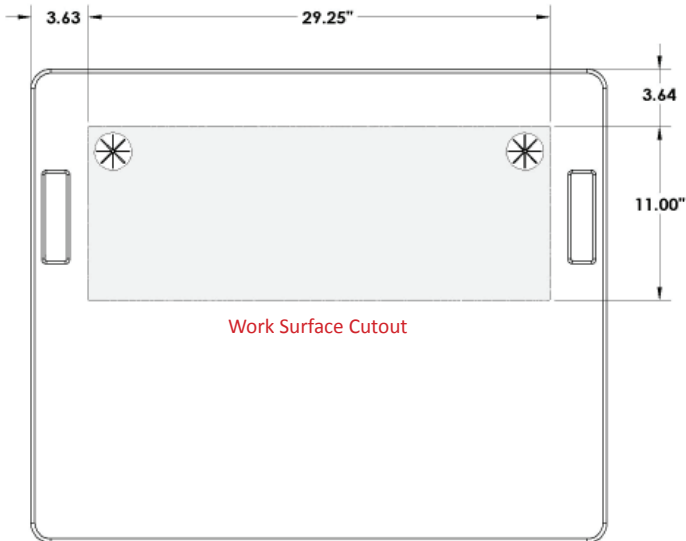

**PD51 - Optional Worktops**

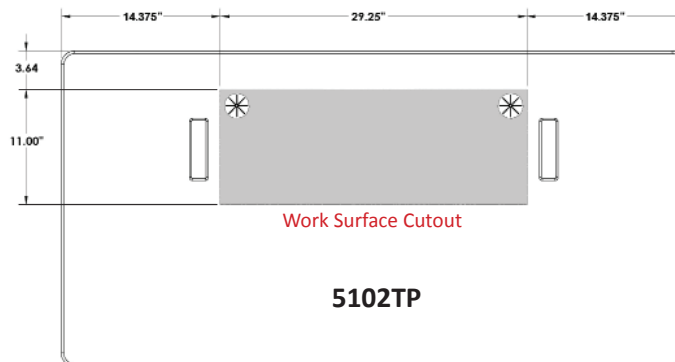
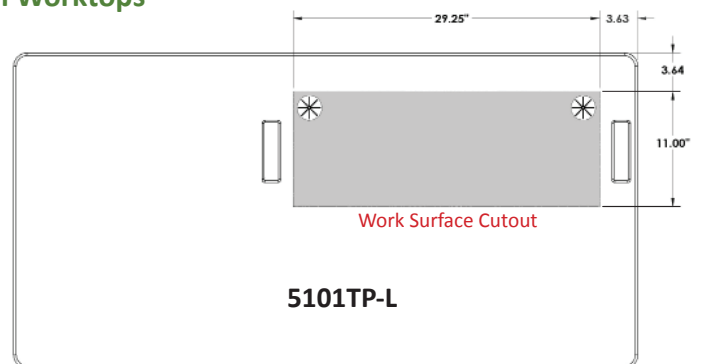
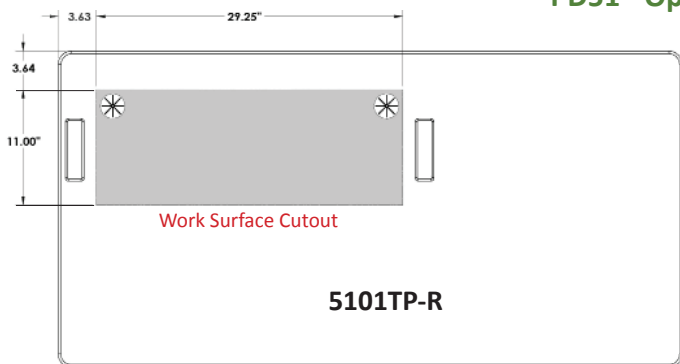

Code **CO** No Custom Cutout  
Code **CC** Custom Cutout (Specify on Cutout Area Above)

- Cutout Area - **Work Surface** (29.25"W X 11"D)
- Cutout Area - **Removable Console Top** (29.25"W X 10"D)
- Cutout Area - **Optional Worktop** (29.25"W X 11"D)