

Thank you for purchasing AVFI's 324 Table.
These instructions will guide you through it's assembly.
Additional add-on furniture will have its own instructions.

Note: If you cannot understand these instructions or are concerned about the safety of the installation
Contact a qualified contractor or contact AVFI at 1-877-834-3876. For indoor use only

Confirm all parts are included before you begin assembly. Extra hardware is provided and will be left over.
2 people are recommended to assemble this table. Assembly time approx 1 hour.

Supplied Parts:

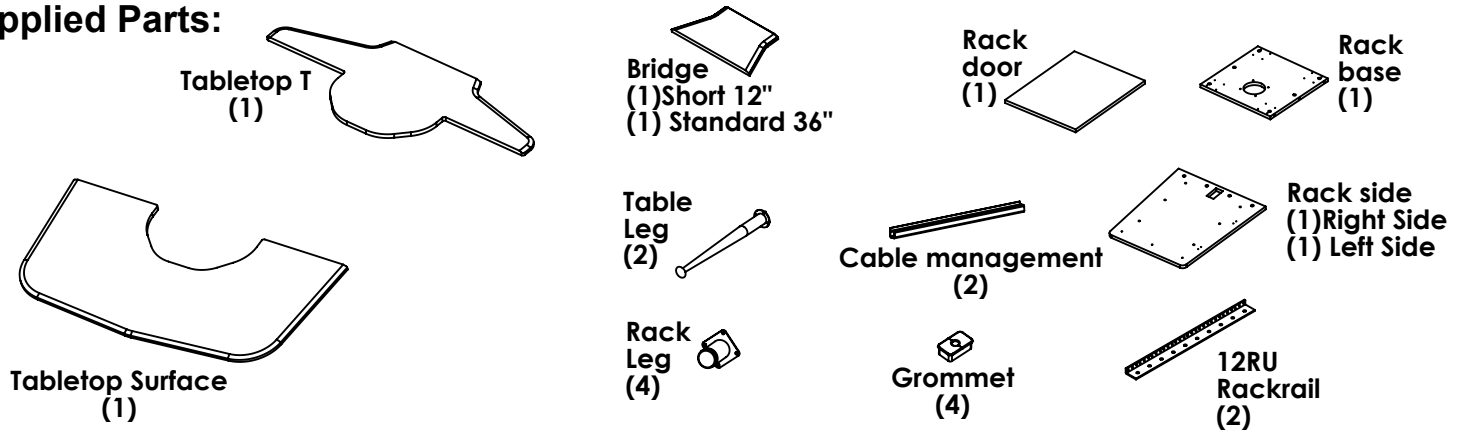

Supplied Hardware:

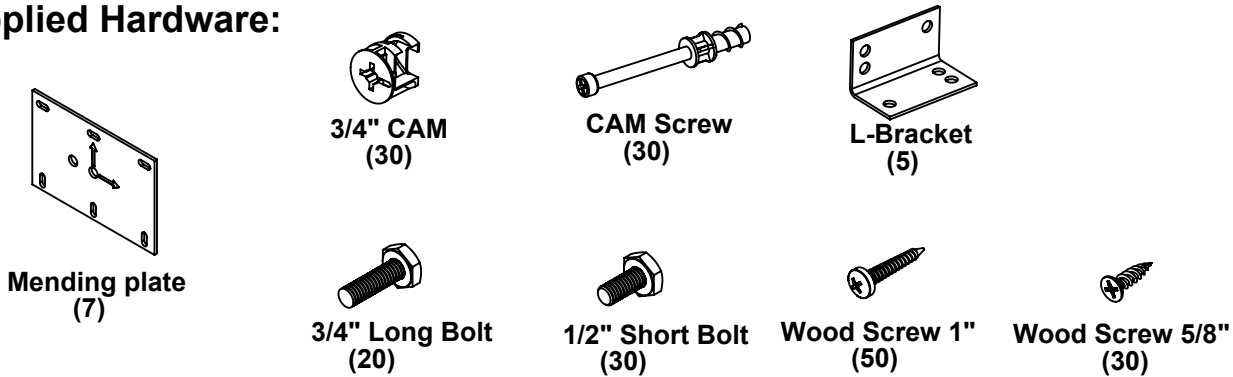

Tools required:

(Not Included)



Step 1

Attaching Legs

1) Using a ratchet and a 7/16 socket tighten both legs as shown.

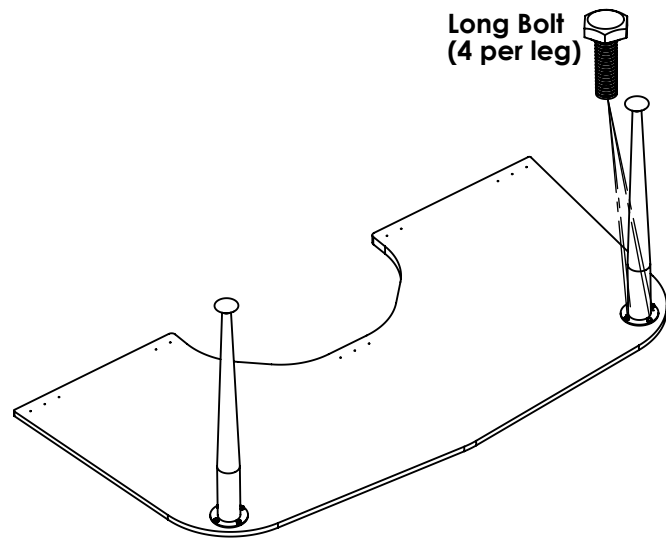

Step 2

Inserting fasteners

1) On a non abrasive surface such as carpet Carefully Flip table pieces so black laminate side faces up. (not shown)

2) Using a Philips (+) screwdriver insert the cam screws into available holes on parts shown.

3) Insert quarter turn cams into parts shown with arrow pointing to nearest edge.

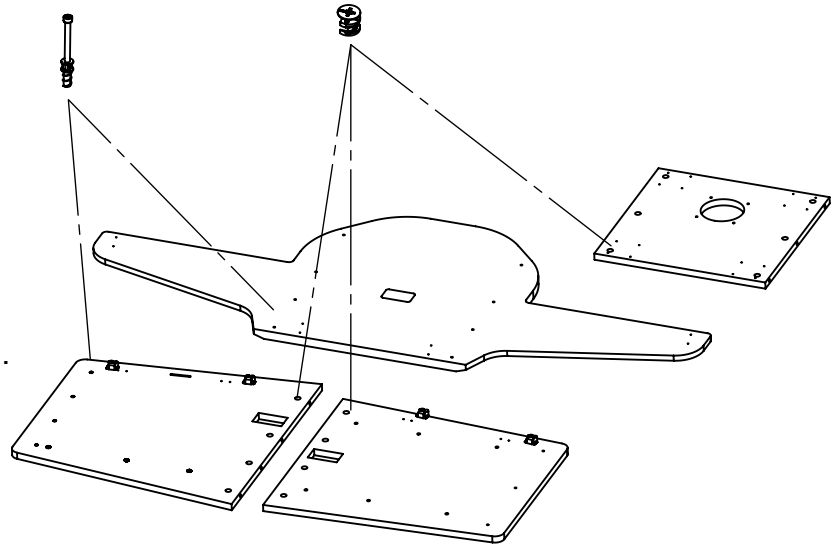

Step 3

Assembling rack

1) Apply the sides to the base piece. Do not tighten the fasteners yet.

2) Insert the side pieces onto the rack table top. Tighten all with a philips(+) screwdriver.

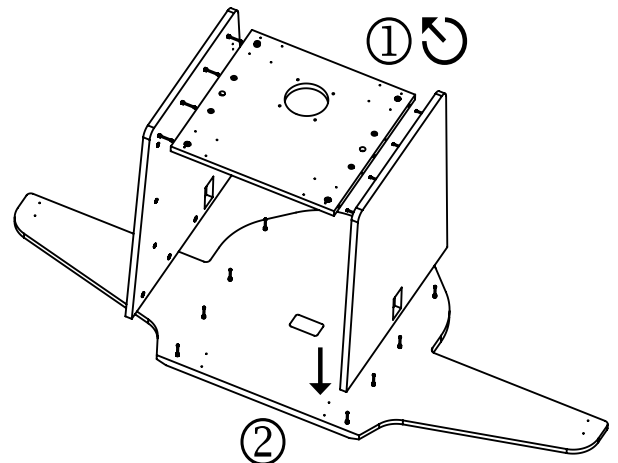

Step 4

Adding legs to the rack.

Using wrench or socket 7/16 , Bolt all 4 legs to the bottom of the rack using included Short bolts.

Leg height adjustment: Adjust the legs to the lowest position.

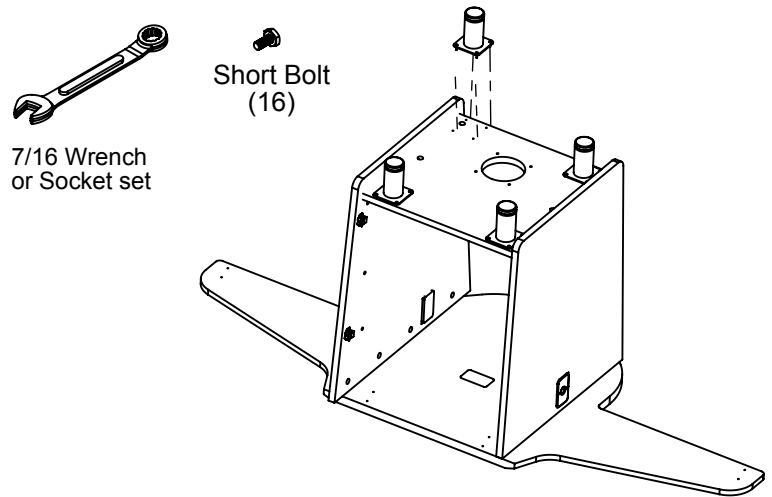

Step 5

Adding rackrails to the rack.

1) Using a wrench or socket and included hex bolts. Screw both rackrails into the metal inserts already in the sides.

2) Carefully roll the rack over onto its legs. (not shown)

 Do not lift by the wings

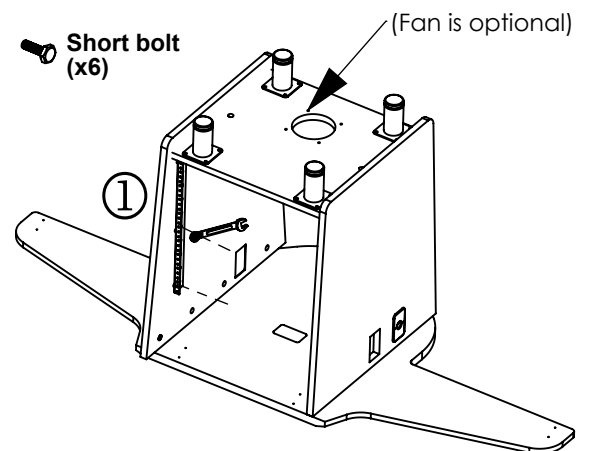

Step 6

Positioning and attaching bridge.

Position rack space where required holding bridge in place as a spacer.

Bridge may be attached to a wall (shown), furniture or a TP800 stand.

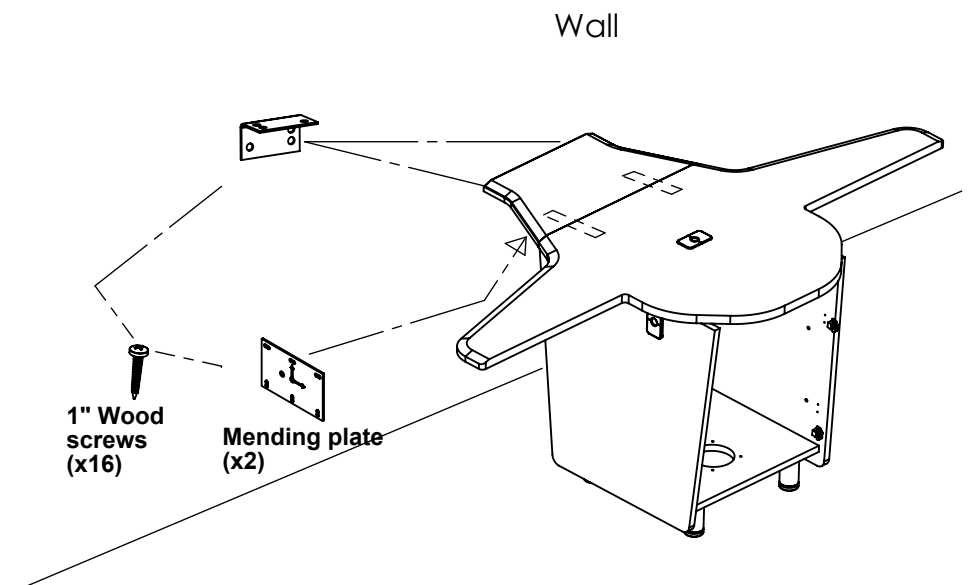

AUDIO VIDEO FURNITURE INTERNATIONAL

288 Don Hillock Drive, Aurora, Ontario L4G 0G9 www.video-furn.com
Toll Free: 1-877-834-3876 Fax: 1-905-751-1488 Local: 905-751-1459

Step 7

Attaching tables and rack

butt table pieces together as shown.
Lift pieces to move them, do not drag.

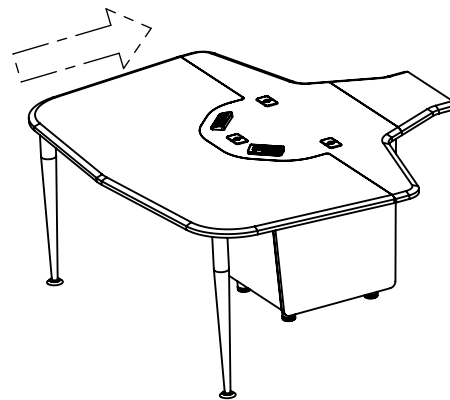

Step 8

Adding Mending Plates

Make sure table pieces are butted together tightly. From underneath the table. Use a cordless driver, insert 6 wood screws per mending plate.

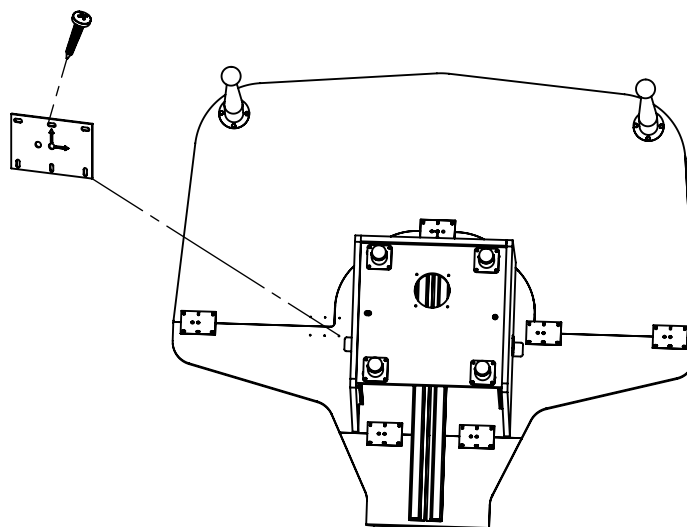

Step 9

Applying Cable management

Remove sticker backing and apply 2 lengths of cable management.

Using a screwdriver or driver insert 3 short wood screws per cable management strip. One at each end and one approx in center.

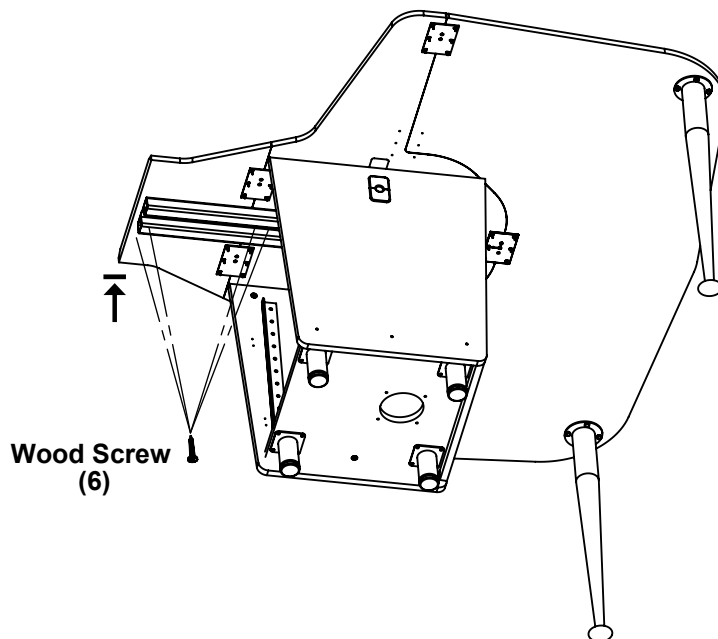

AUDIO VIDEO FURNITURE INTERNATIONAL

288 Don Hillock Drive, Aurora, Ontario L4G 0G9 www.video-furn.com
Toll Free: 1-877-834-3876 Fax: 1-905-751-1488 Local: 905-751-1459

Step 10

Adding Door/cover

Press door onto grab catches as shown.

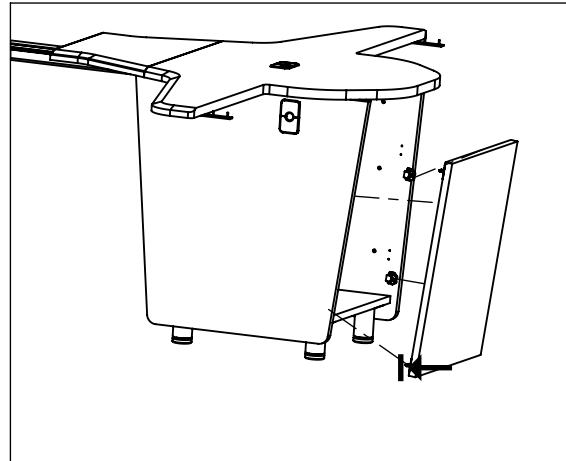
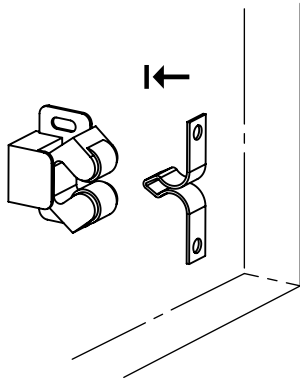

Table surface
not shown

Optional accessories

PLM1022 and shield

- 1) Place PLM1022 over grommet on top of rack.
- 2) Center PL1022.
- 3) Use wood screws to secure PLM1022 onto rack top surface. (not pre-drilled)
- 4) Attach LCD Monitor as per PLM1022 instructions.
- 5) Rest Monitor shield leaning against back of LCD monitor. Shield rests on rubber feet.

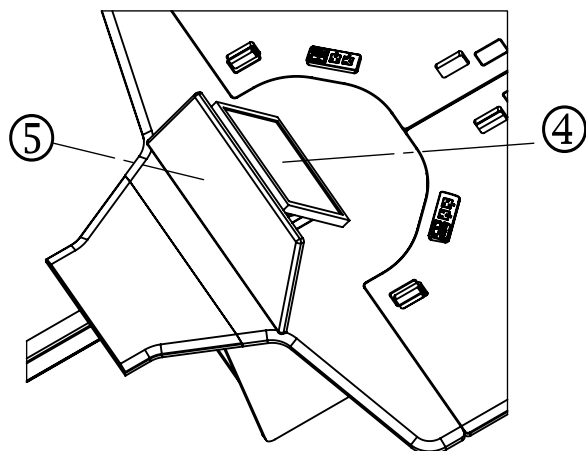
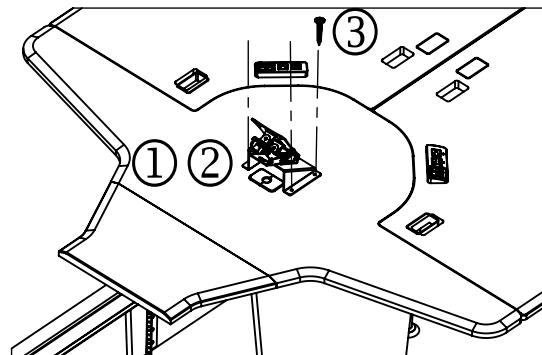

Table is finished!
Just run wiring and cables.

AUDIO VIDEO FURNITURE INTERNATIONAL

288 Don Hillock Drive, Aurora, Ontario L4G 0G9 www.video-furn.com
Toll Free: 1-877-834-3876 Fax: 1-905-751-1488 Local: 905-751-1459