

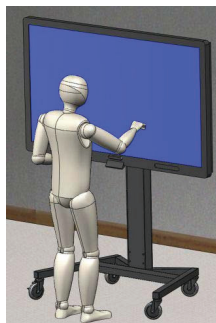

The **PM-XFL-LIFT** heavy duty floor mount for single monitors has motorized lift capability for up to 90" flatscreen TV's or \*SMART Board® interactive displays (landscape orientation) weighing up to 265 lbs or 120 kg. It is a self supporting, wheeled stand. Ideal for environments where adjustable height or ADA is required.

### Standard Features

- Accommodates up to 90" displays and \*SMART Board® interactive displays (265 lbs max)
- 400X200mm minimum to 800x440mm maximum VESA
- 20" travel electric Worm-Drive actuator for safety and reliability
- Cable push-button remote for easy incremental adjustments
- 5" metal casters with ballbearings, non-marking wheels and dustguards, 2 are locking
- Wiring channel inside main pillar
- Scratch resistant powder coat finish

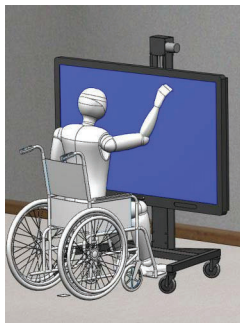

### Options

- **TVCB-XL** Camera bracket (For video conference applications allowing camera to ride up & down with the screen)
- **BKT-ROOM** Cisco Room & Room Plus camera bracket (using TVCB)
- **CBB-TV** Under TV camera bracket (26" - 80" TV's)
- **PM-PB** Mounted six outlet power bar with 10 ft. cord
- **PM-2RU** 2U bracket
- **BKT-C20** C20 codec bracket
- **BKT-SX20** SX20 Codec bracket
- **PM-HDCB** HD Codec bracket
- **BKT-MCM** Mac mini bracket
- **PM-PC-BKT** Codec/PC bracket
- **SYZ1/SYZ2/SYZ3** Laptop shelf
- **M38L** 4x Levelers for non-mobile applications

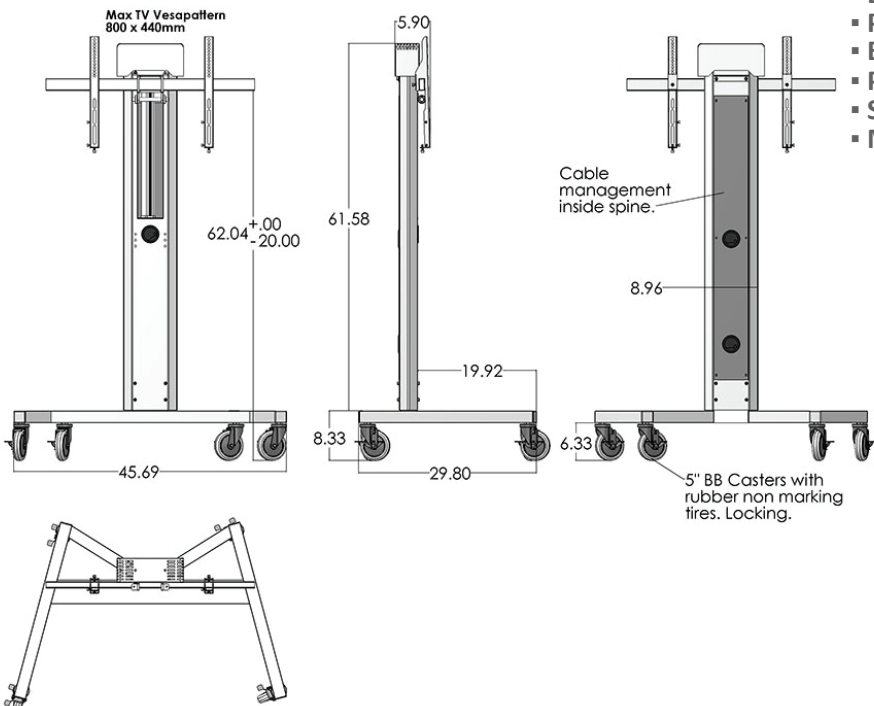

### Specifications

**Model:** PM-XFL-LIFT  
**Width:** 46" or TV  
**Depth:** 29-1/2"  
**Height:** 65" minimum (Varies)

### Colors



The information contained in this drawing is the sole property of Audio Visual Furniture International. Any reproduction in part or as a whole without the written permission of Audio Visual Furniture International is prohibited. We can build or modify stock configurations to suit customer specifications. Please contact us to discuss how this service can help meet your needs. Some quantity restrictions may apply. Specification subject to change without notice. Computers, cameras, monitors, etc. are shown to illustrate product usage and are not included unless otherwise noted. SMART Board® is a trademark or registered trademark of SMART Technologies ULC in the U.S. and/or other countries. Not verified by SMART