

5104DE Desk End for PD51 Series

This document shows assembly and installation of the 5104DE Desk End.

This Desk End fits PD51 Series main components only.

Parts are reversible for left or right-hand applications.

Note: If you cannot understand these instructions or are concerned about safety of the installation contact a qualified contractor or contact AVFI at 1-877-834-3876



Supplied Parts

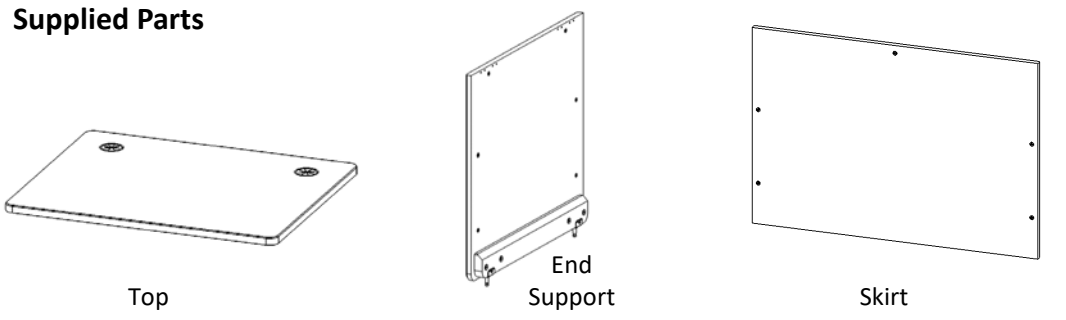

Supplied Hardware

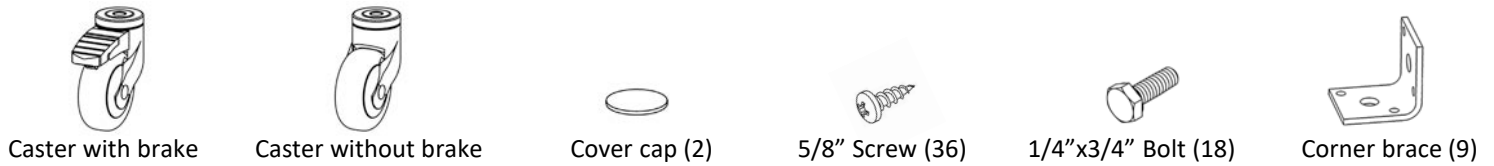

Tools required

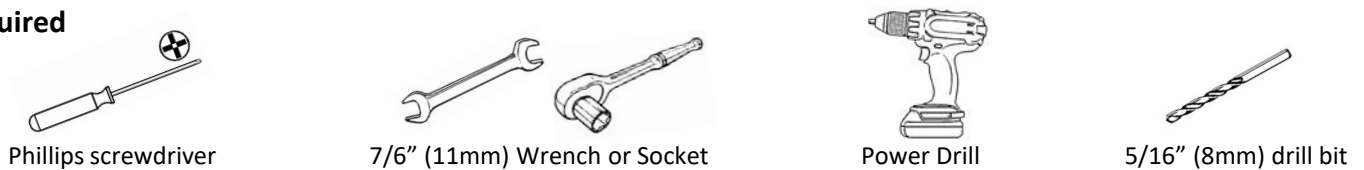

- Once it's determined on which side of the main component the 5104DE will be installed on, install hardware to the End Support panel as shown below for Left-hand or Right-hand application.
Do Not overtighten the bolts, all parts will be reinforced with screws at the end of assembly.

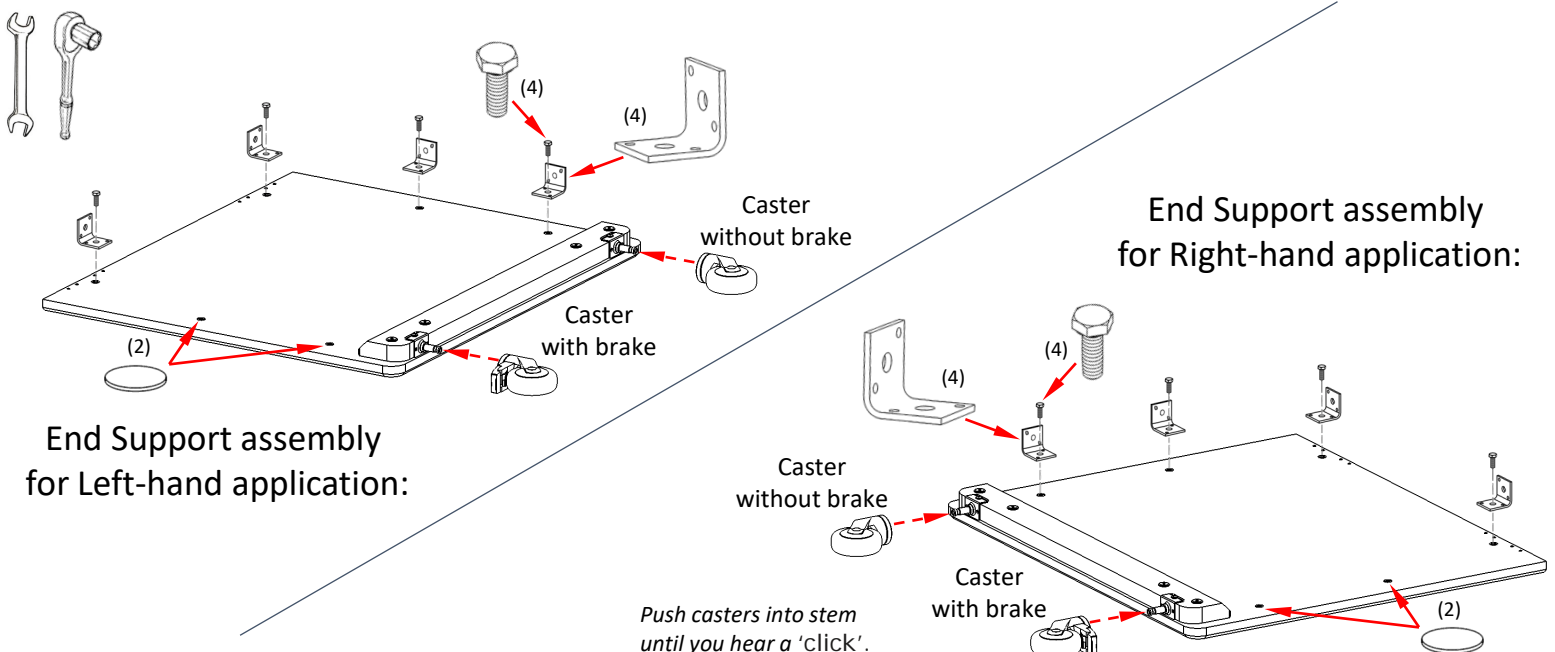

5104DE Desk End for PD51 Series

- 2** Locate the four required 2.5mm pilot holes covered by thermowrap film shown below. These holes are available on both sides of the PD51 Series main components, PD51, PD5107, PD5103, RK5105 & RK5106 (*Installation with RK5105 is used as an example*).

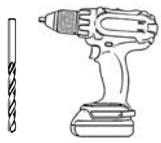

Installation for
Left-hand application:

Installation for
Right-hand application:

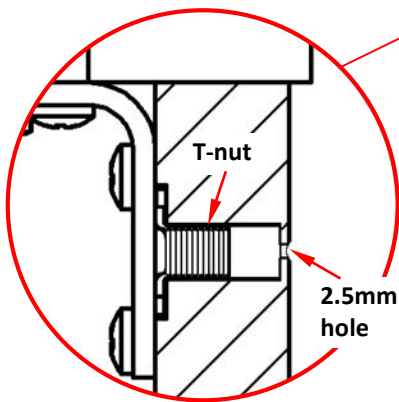

Drill using a 5/16" (8mm) just far enough to allow the 1/4" bolt go through and catch the T-nut.



Do not drill more than 1/8" (3mm) deep to avoid damaging the T-nut.

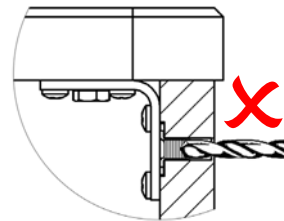
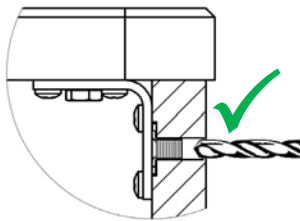

- 3** After drilling, install corner braces with bolts needed to attach the Skirt and Top panels as shown below. Do Not overtighten the bolts, all parts will be reinforced with screws at the end of assembly.

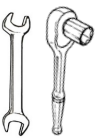

Installation for Left-hand application:

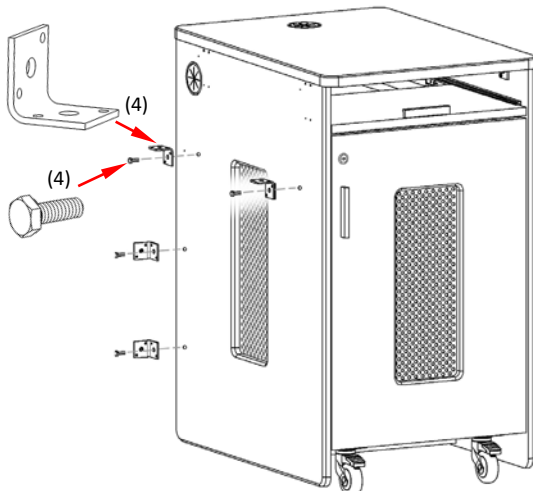

Installation for Right-hand application:

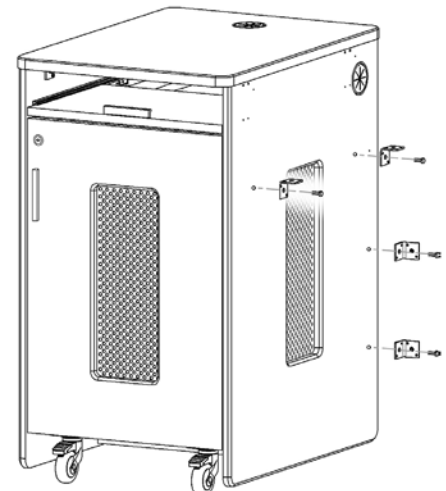

5104TP Bridge Top for PD51 Series

4 Attach Skirt panel to the side of the component and install a corner brace that will attach the Top panel as shown below. Do Not overtighten the bolts, all parts will be reinforced with screws at the end of assembly.

Two people are required to complete the installation.



Installation for Left-hand application:

Installation for Right-hand application:

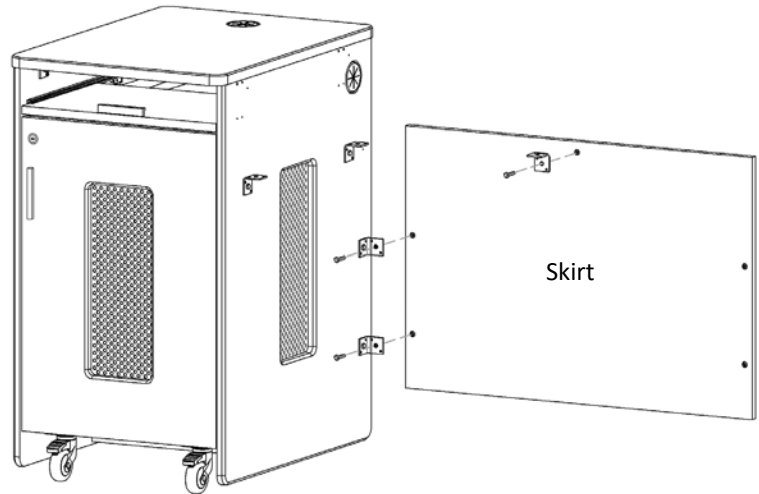
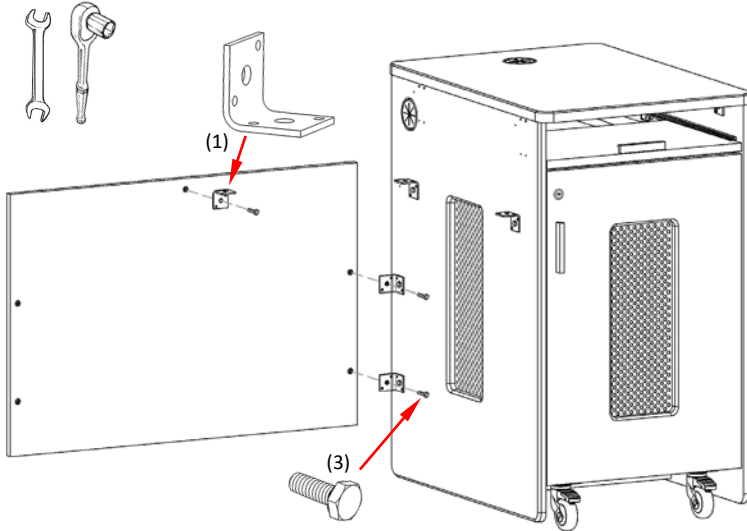

3 Complete installation by attaching the End support and Top panels with bolts as shown below. Two people are required to complete the installation.



Installation for Left-hand application:

Installation for Right-hand application:

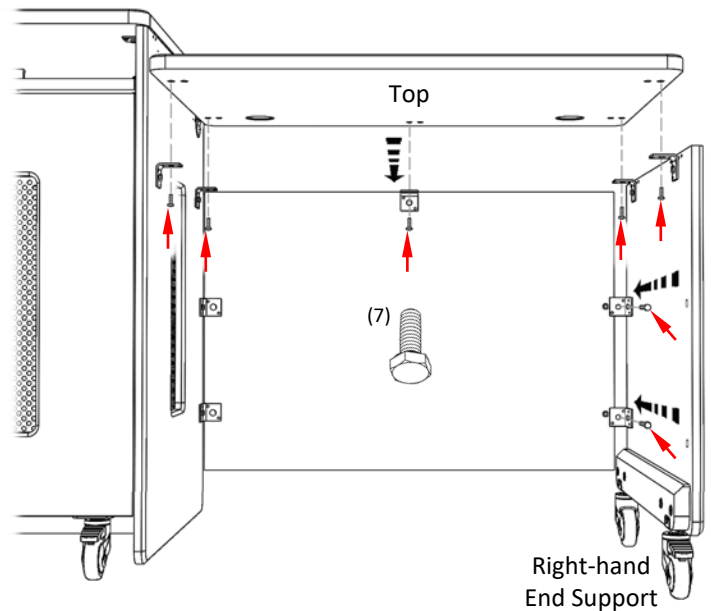
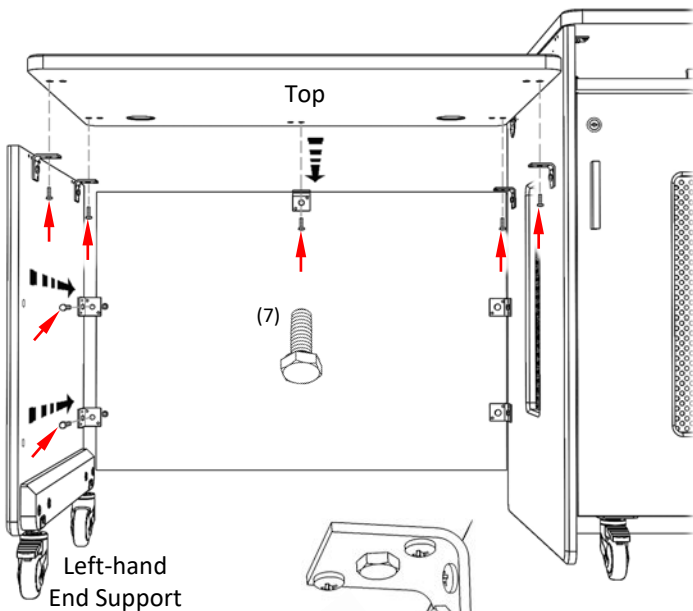

Once all parts are in place and bolts are tightened, drive in the 5/8" screws provided to all corner braces to reinforce.

**Assembly and installation
completed, enjoy!**