

MFT6024 Modular Folding Table System



MFT6024-2P image shown.



MFT6024-2P connected side by side

MFT6024-2P Folded

The MFT6024 Modular Folding Table System is a training and conference room solution for both professional and private bureaus.

AVFI's unique design incorporates hardware with an Intelligent Folding System that allows the tables to be mobile, linked together and easily folded for storage. Several sizes and shapes are available for modular room layouts and configurations, suitable for conference and training room areas.

Standard Features

- Space-saving table folding system, elegant design, desk frame from grey powder coated steel and locking casters for mobility.
- Highly resistant thermowrap Top surface [surf\(x\)](#) (Check available finishes).
- 2x Power Panels (2x outlet, 2x 2.0A USB) and 2x grommet per table, color: Black (MFT6024-2PSTD does not include power).
- Steel Leveling Desk Top Connectors.
- Ships flat packed.

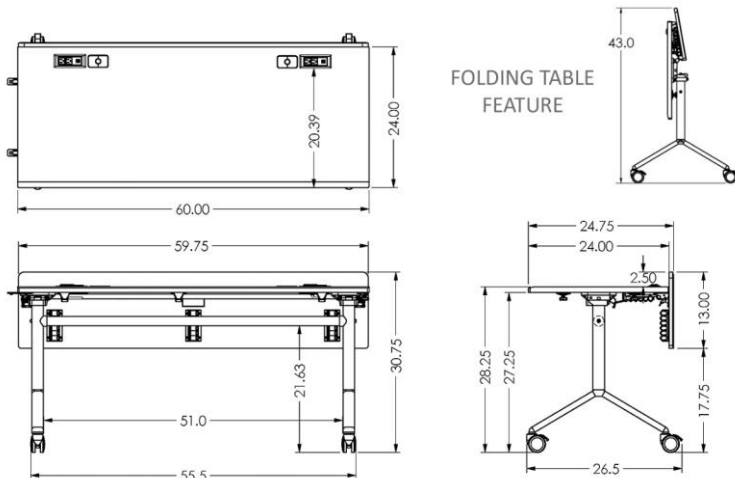
Options

- **CUBM3** 3 Module Power & Data panel, Black.
 - 2 Tamper Resistant AC Outlets.
 - 1 Cat 6 port (w/pigtail).
- **CUBM4** 4 Module Power & Data panel, Black.
 - 2 Tamper Resistant AC Outlets.
 - 1 Cat 6 port (w/pigtail).
 - 1 HDMI Port.
- **PB** Six outlet power bar with 10ft. cord

TABLE COMPONENTS AVAILABLE

See configuration page for details and options.

- MFT6024-2P 2-Person Folding Table
- MFT6024-2PSTD 2-Person Standard Folding Table (does not include power)
- MFT6024-2PEL 2-Person Folding Table-End Left
- MFT6024-2PER 2-Person Folding Table-End Right
- MFT6024-3PCL 3-Person Folding Table-Corner Left
- MFT6024-3PCR 3-Person Folding Table-Corner Right
- MFT6024-3PL 3-Person Folding Table-Left
- MFT6024-3PR 3-Person Folding Table-Right
- MFT6024-2PW20 2-Person Wedge Folding Table, 20° angle.



Specifications

Model: MFT6024
Width: 60" - 84.75"
Depth: 24.75"
Height: 30.75"

Finishes:



Other finishes are available. Check website.

The information contained in this drawing is the sole property of Audio Visual Furniture International. Any reproduction in part or as a whole without the written permission of Audio Visual Furniture International is prohibited. We can build or modify stock configurations to suit customer specifications. Please contact us to discuss how this service can help meet your needs. Some quantity restrictions may apply. Specification subject to change without notice. Computers, cameras, monitors, etc. are shown to illustrate product usage and are not included unless otherwise noted.

MFT6024 Modular Folding Table System

**AUDIO VISUAL
FURNITURE
International**

TABLE COMPONENTS



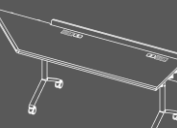
MFT6024-2PSTD
60"W x 24"D x 28.25"H



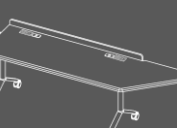
MFT6024-2P
60"W x 24.75"D x 30.75"H



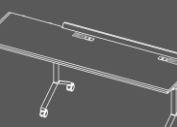
MFT6024-2PW20
63"W x 24"D x 28.25"H



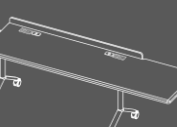
MFT6024-2PEL
84.75"W x 24.75"D x 30.75"H



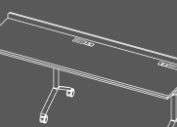
MFT6024-2PER
84.75"W x 24.75"D x 30.75"H



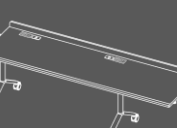
MFT6024-3PCL
84.75"W x 24.75"D x 30.75"H



MFT6024-3PCR
84.75"W x 24.75"D x 30.75"H



MFT6024-3PL
84.75"W x 24.75"D x 30.75"H



MFT6024-3PR
84.75"W x 24.75"D x 30.75"H

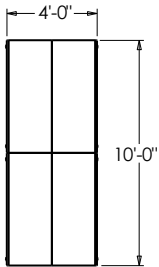
TYPICAL CONFIGURATIONS

*Chairs are not included

MFT6024 - Boardroom



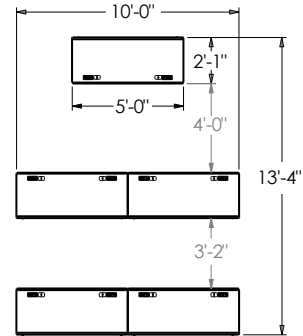
Table Components Included:
4x MFT6024-2PSTD



MFT6024 - Learning



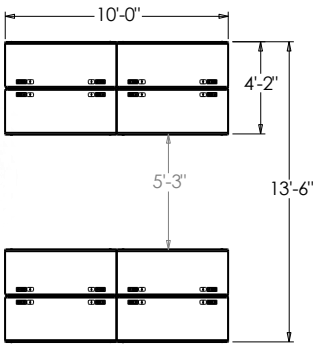
Table Components Included:
5x MFT6024-2P



MFT6024 - Back-to-Back



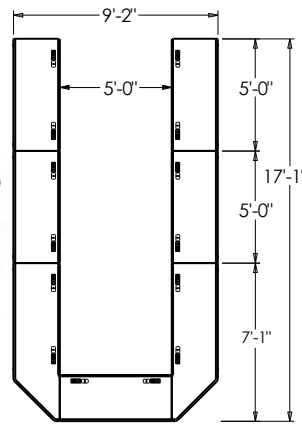
Table Components Included:
8x MFT6024-2P



MFT6024 - U-Shape



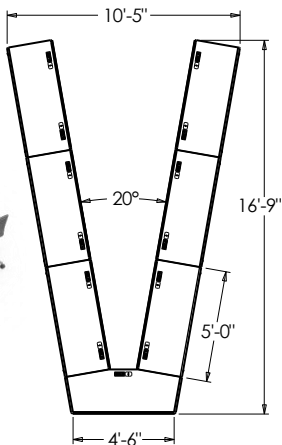
Table Components Included:
5x MFT6024-2P
1x MFT6024-2PER
1x MFT6024-2PEL



MFT6024 - V-Shape



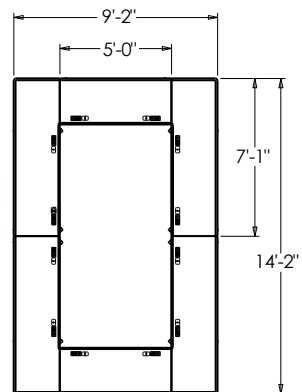
Table Components Included:
6x MFT6024-2P
1x MFT6024-2PW20



MFT6024 - Square

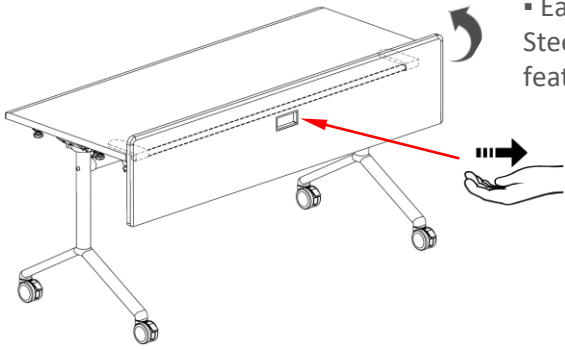


Table Components Included:
2x MFT6024-2P
2x MFT6024-3PCL
2x MFT6024-3PCR



Note: Allow ± 0.5" on all dimensions

FEATURES



- Easy to use, space-saving table folding system. Steel desk frame is powder coated grey and features locking casters for mobility.



- Highly resistant thermowrap Top surface [surf\(x\)](#) (Check available finishes).
- Integrated 2x Power Panels (2x outlet, 2x 2.0A USB) and 2x grommet per table, color: Black (MFT6024-2PSTD does not include power).



OPTIONAL POWER & DATA

- **CUBM3** 3 Module Power & Data panel, Black.
 - 2 Tamper Resistant AC Outlets.
 - 1 Cat 6 port (w/pigtail).



- **CUBM4** 4 Module Power & Data panel, Black.
 - 2 Tamper Resistant AC Outlets.
 - 1 Cat 6 port (w/pigtail).
 - 1 HDMI Port.



- Integrated under work surface Cable Clamps with slots for cable management .

- Steel Leveling Desk Top Connectors synchronizes firm connections.

