

PD3008 Order Form

Date _____
 AVFI Sales REP _____
 Customer Signature _____

Quote No. _____
 Customer No. _____
 AVFI No. _____

Office Use Only

To generate your order form, please refer to the information provided below to insert the alphabetic and/or numeric code in the respective category boxes. Please note that without this filled out Order Form, your purchase **cannot** be processed.

1	2	3								4
Product Model	Finish	Chargeable Accessories (One Code Per Box)								Custom Cutouts
PD3008										

1 Choose Model Style (Front Panel)



Code **PD3008**

2 Choose Product Finish

Standard Finishes (Ships within 1-15 business days)

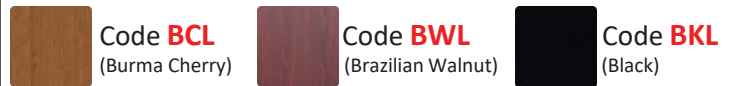

Optional Finishes (Ships within 20 business days)

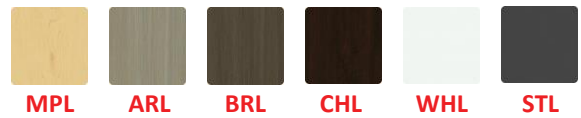

3 Chargeable Accessories (Check all that apply)

Code O0	No Accessories	Qty _____
Code A1	SH-FL Folding Side Shelf	Qty _____
Code B1	9031-1 1U Utility Metal Shelf	Qty _____
Code B2	9031-2 2U Utility Metal Shelf	Qty _____
Code B3	9031-3 3U Utility Metal Shelf	Qty _____
Code B5	9052-2 2U Sliding Metal Drawer	Qty _____
Code B6	9052-3 3U Sliding Metal Drawer	Qty _____
* Code D1	MIC-18 MX418 S/C Microphone	Qty _____
* Code D2	LIGHT-18 Gooseneck Light	Qty _____
* Code D3	FM3 Timer/Clock	Qty _____
Code D4	FAN Quiet Cooling Fan	Qty _____
Code E1	PB 6 Outlet Power Bar	Qty _____
* Code E3	CUB3 Round Cable Well	Qty _____
* Code E4	SF-PB3 3 Outlet Power Bar	Qty _____
* Code E5	CUB5 Black Round Cable Well	Qty _____
* Code E6	CUB5 Silver Round Cable Well	Qty _____
* Code E7	PC-PATCH Power-Data Module	Qty _____
* Code E8	CUB8 Tabletop Cable Well	Qty _____
* Code EA	CUB4S Silver Power Panel	Qty _____
* Code EB	CUB4B Black Power Panel	Qty _____
* Code EK	CUBM3 3 Module Power & Data Panel (Black)	Qty _____
* Code EL	CUBM4 4 Module Power & Data Panel (Black)	Qty _____
Code H4	RR10 10U Set of Rack Rails (Rear)	Qty _____
Code J1	9107 Lacing Bar	Qty _____
Code K1	C900S Single Monitor Arm	Qty _____
Code K2	C900D Dual Monitor Arm	Qty _____
Code K3	PLM1022 Monitor Mount	Qty _____
Code K4	MM1232 LCD Monitor Mount	Qty _____
Code M5	MCB1925 Monitor/Camera Bracket	Qty _____
Code Q1	LEV4AX4 4x Levelers for Non-Mobile Applications	Qty _____

4 Custom Cutout Option (Extra charges will apply)

Please indicate custom cutout location on the drawing below

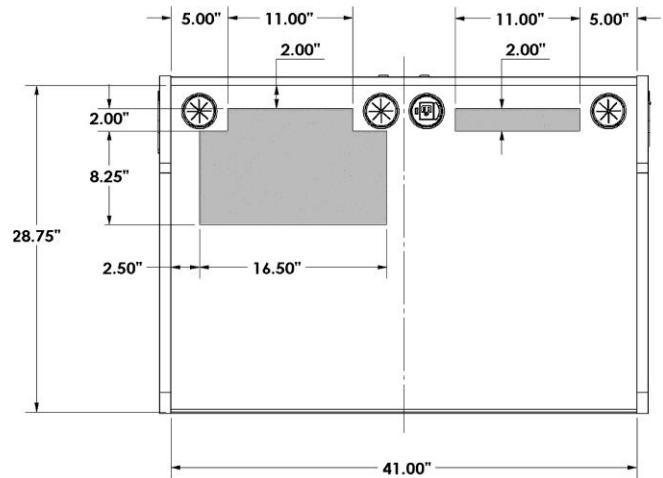

Code **C0** No Custom Cutout

Code **CC** Custom Cutout (Specify on Cutout Area Above)

■ Cutout Area (1x - 16.5" W x 10.25" D)
 (1x - 11" W x 2" D)

* Cutout Required (Extra Charges will apply)

Comments (Please use this section to provide additional information)

Notes

CAD Drawings/Symbols

CAD drawings are available by request at sales@veggroup.net

Custom Cutouts Estimated lead time within 20 business days from receipt of P.O. and signed drawings.

Customizations

Modifications to design such as shape and/or size variations have to be quoted on a per case basis and are applicable for quantities of 10+ only.