

Features:

- Roll formed shelves with powder coat paint finish
- Cable pass through holes in top and middle shelf
- 4" ball bearing casters, two with locking brake
- 1/4" retaining lip around each shelf
- Cabinet models have locking doors with full length piano hinges
- No slip rubber mat for top shelf
- Drop leaf side shelves fold down



3-Outlet surge suppressing electric assembly with 15' cord



AVJ42KBCDL

Touchboards

205 Westwood Ave, Long Branch, NJ 07740
 Phone: 866-94 BOARDS (26273) / (732)-222-1511
 Fax: (732)-222-7088 | E-mail: sales@touchboards.com



AVJ42KBDL

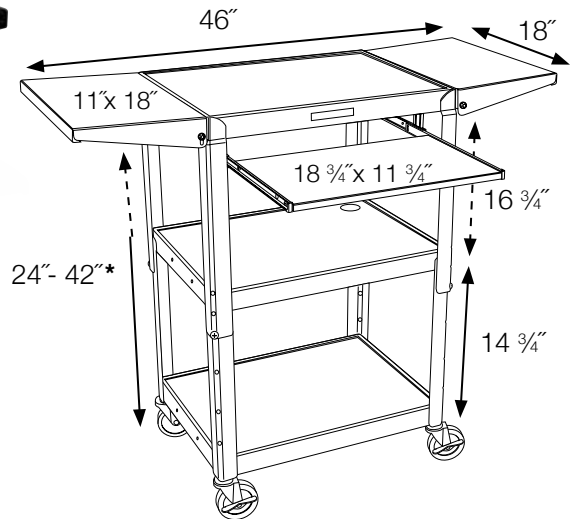

Color Options:	Black	Gray	Red	Burgundy	Blue
		LG	RD	BY	RB