

www.luxorfurn.com  
www.hwilson.com

## Parts List

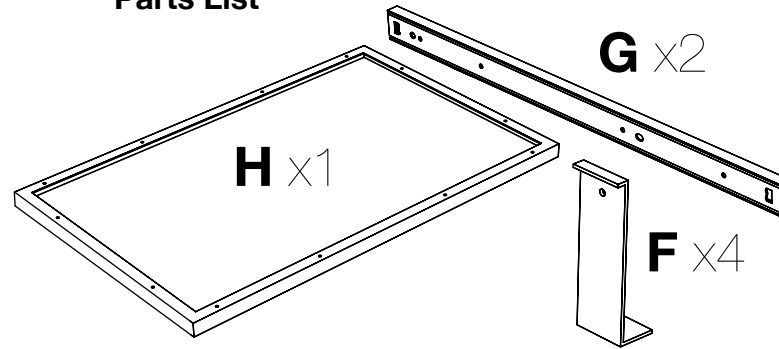

## Tools Required

- Phillips Screwdriver
- Pliers or Adjustable Wrench



## Pullout Shelf Instructions

AVJ42KB, W42AKB

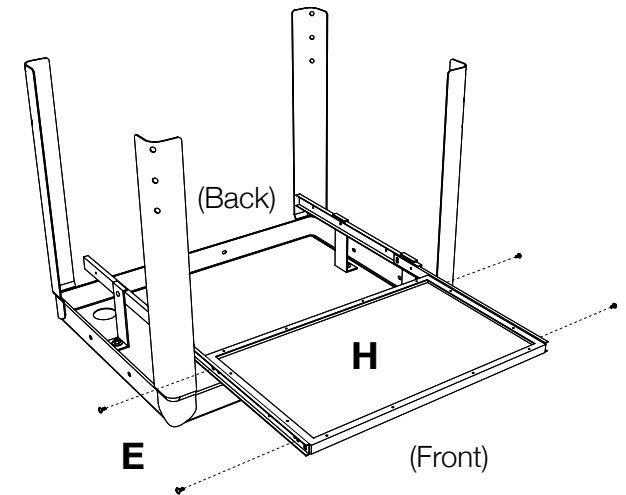
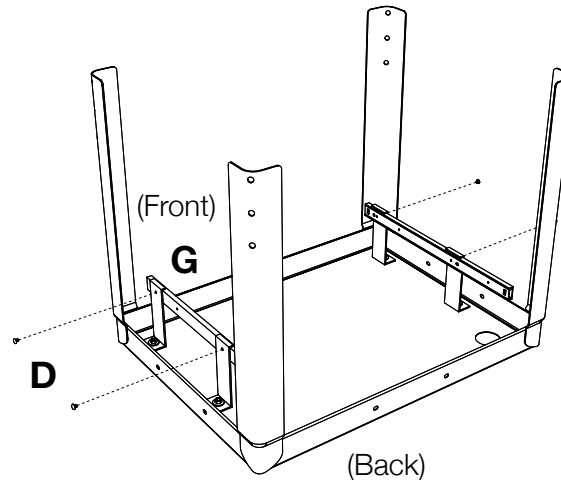
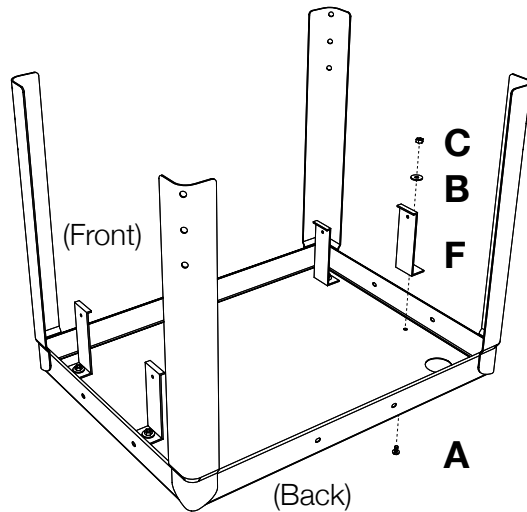

**1**

Take the top shelf of your metal cart and lay it flat. Collect parts: **F**, **A**, **B** & **C**. Push Screw **A** through the hole at the top of the shelf. Lay bracket **F** and washer **B** on top of screw **A**. Take nut **C** and fasten with a screwdriver and pliers.

**2**

Collect parts: **G** & **D**. Align the pullout shelf runner **G** so that the threaded screw holes match up with the holes on bracket **F**. Make sure the runner slides toward the front of the cart. Take screw **D** and fasten through bracket **F** into the threaded screw holes of runner **G**.

**3**

Collect parts: **H** & **E**. Slide out runner **G** so that it is fully extended. Align pullout shelf **H** and runner **G** so that the screw holes meet. Take screw **E** and fasten it through runner **G** into the screw holes of pullout shelf **H**. The pullout shelf assembly is now complete.

## Parts List

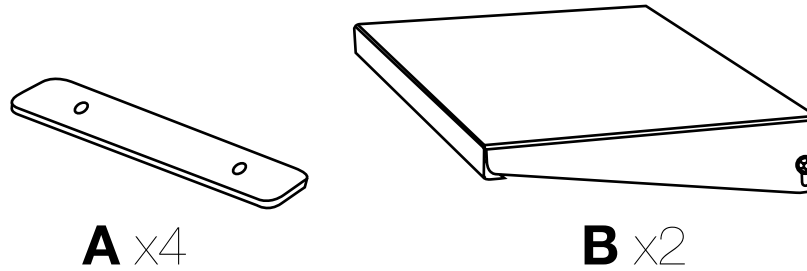

## Tools Required

- Phillips Screwdriver
- Pliers or Adjustable Wrench

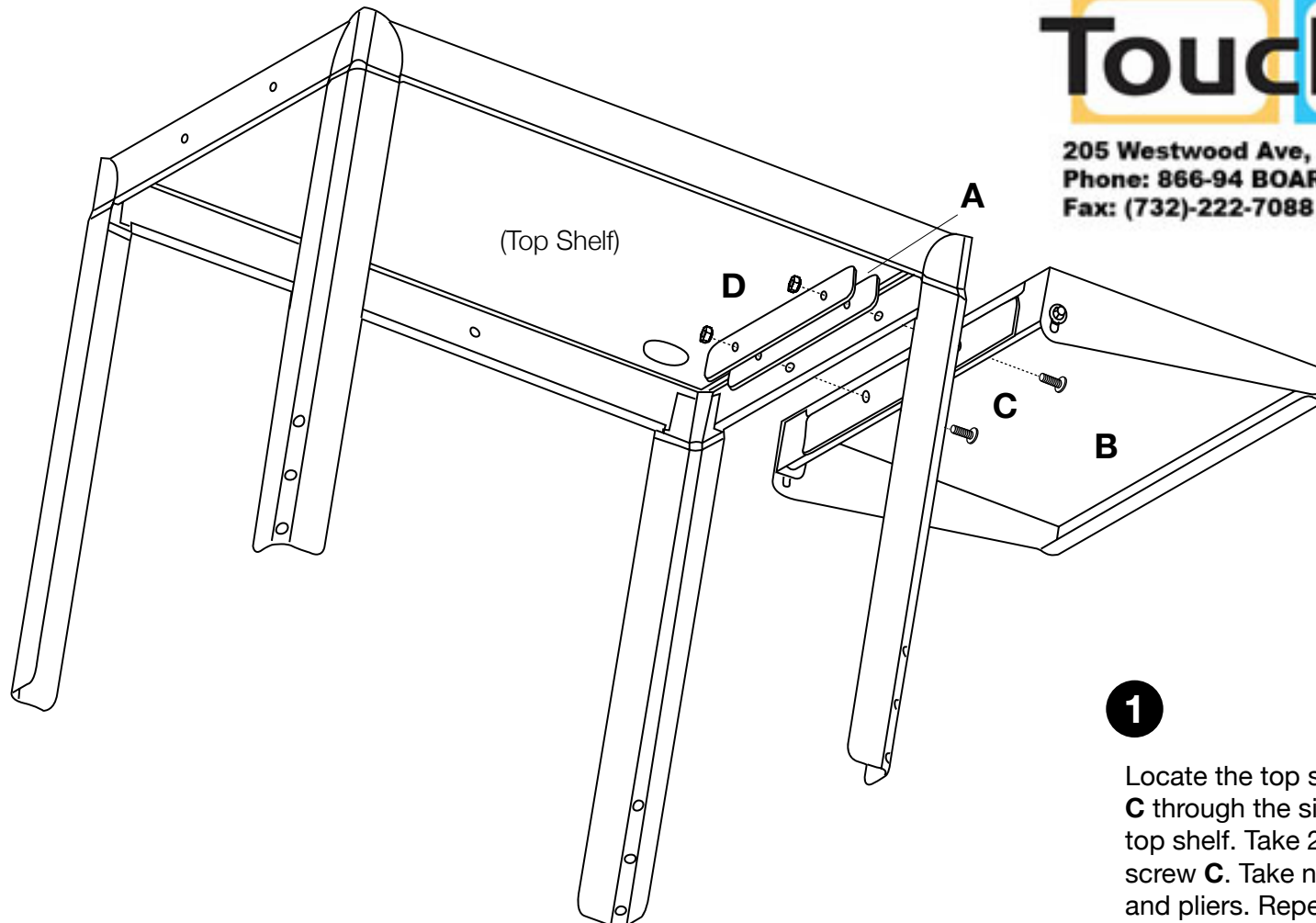

# Touchboards

205 Westwood Ave, Long Branch, NJ 07740  
Phone: 866-94 BOARDS (26273) / (732)-222-1511  
Fax: (732)-222-7088 | E-mail: sales@touchboards.com

**1**

Locate the top shelf of your metal cart. Push screw **C** through the side holes of drop shelf **B** and the top shelf. Take 2 **A** brackets and push them through screw **C**. Take nut **D** and fasten with a screwdriver and pliers. Repeat this on the other side.

www.luxorfurn.com  
www.hwilson.com

## Adjustable Height Metal Cart Instructions

AVJ42, W42A

### Parts List

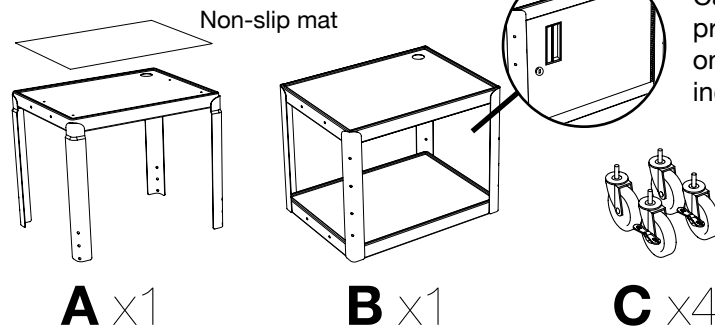

### Tools Required

- Phillips Screwdriver
- Rubber Mallet
- Pliers or Adjustable Wrench

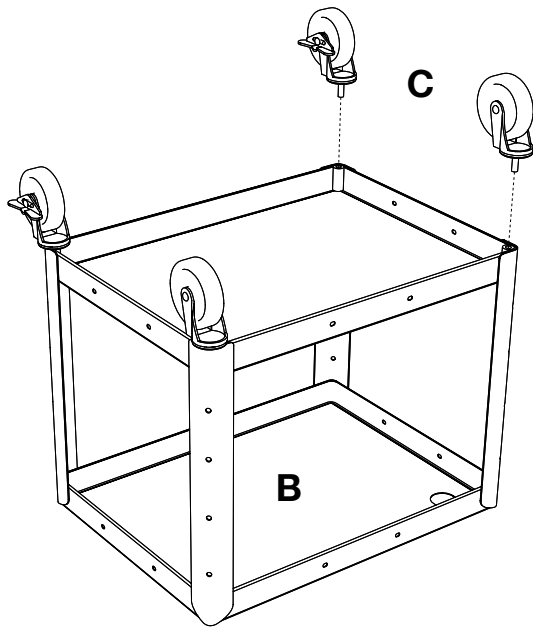
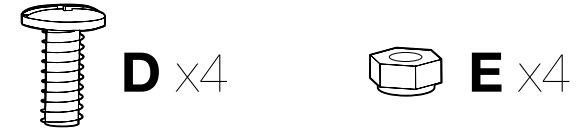

**1**

Position the bottom shelf **B** so that the caster holes are facing up. Insert caster **C** into the caster holes on the bottom of shelf **B**. Use a mallet to set the casters properly.

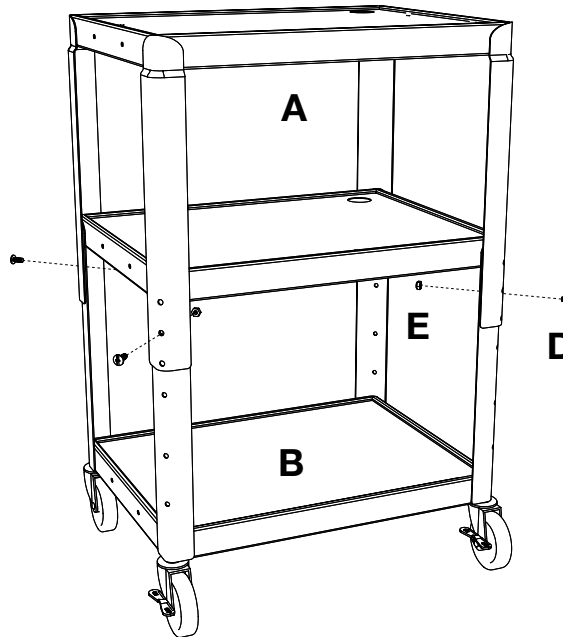

**2**

Flip bottom shelf **B** so that it is on its side. Set top shelf **A** so that it overlaps bottom shelf **B**. Align the screw holes so that the top shelf **A** is at the desired height.

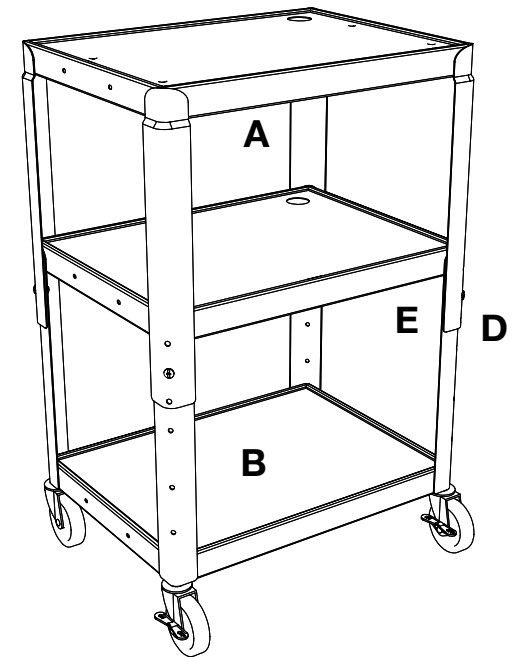

**3**

Insert screw **D** through the aligned screw hole of **A** and **B** and fasten nut **E** with pliers and screwdriver. Place Non-slip mat on desired shelf. The cart is now complete.

[www.luxorfurn.com](http://www.luxorfurn.com)  
[www.hwilson.com](http://www.hwilson.com)

## Electric Assembly Instructions

Number of outlets  
may vary.

### Parts List

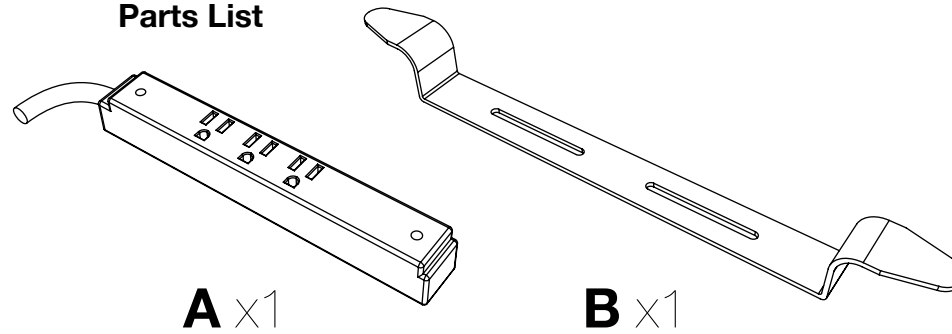

### Tools Required

- Screwdriver

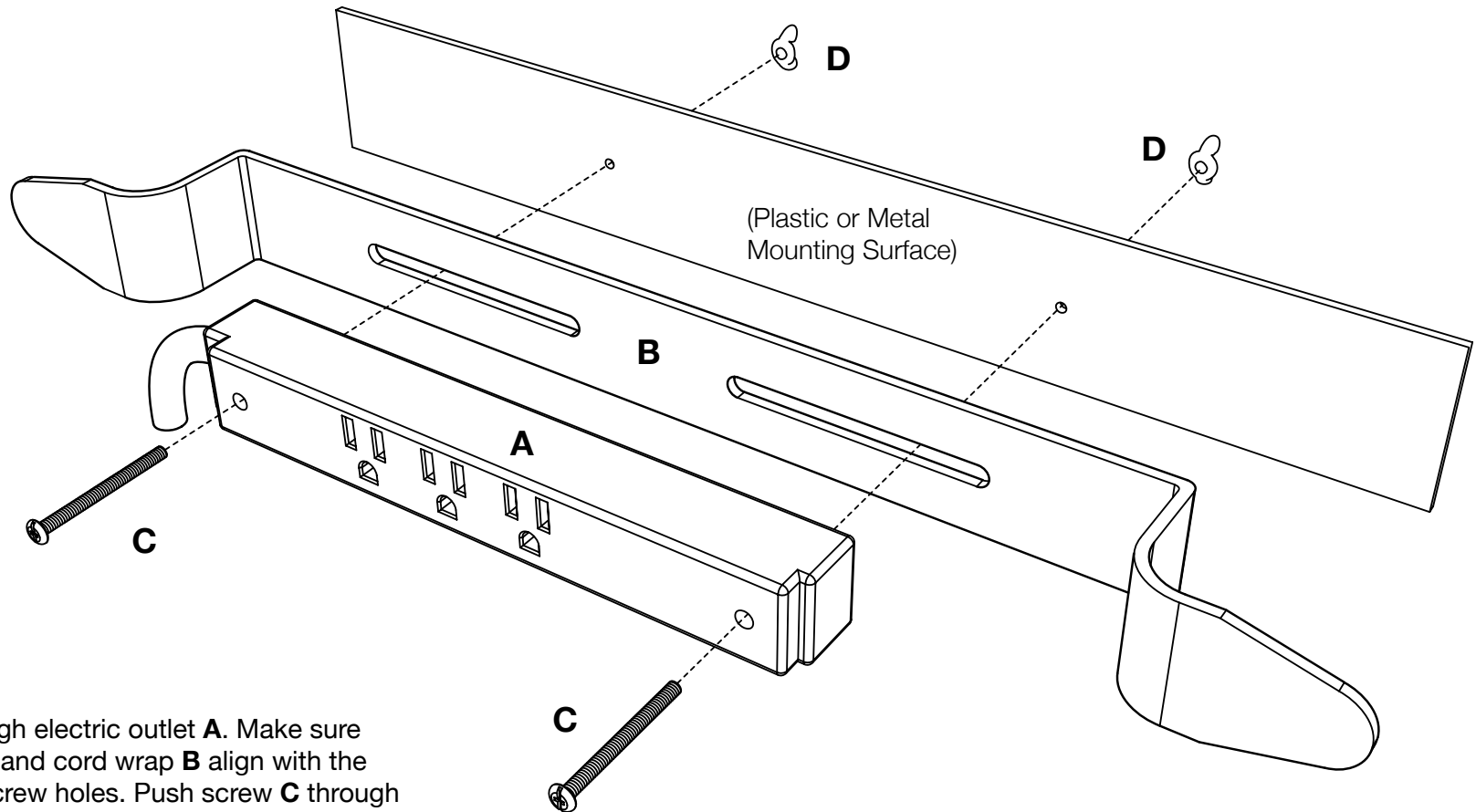
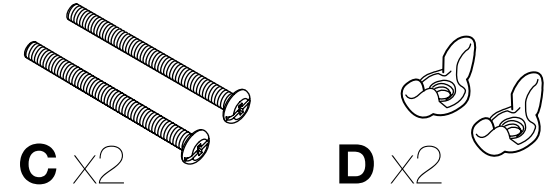

**1**

Push screw **C** through electric outlet **A**. Make sure the electric outlet **A** and cord wrap **B** align with the mounting surface screw holes. Push screw **C** through cord wrap **B** and the mounting surface screw holes. Use wing nut **D** and screwdriver to fasten.