

Maximum load rating: 300 lbs

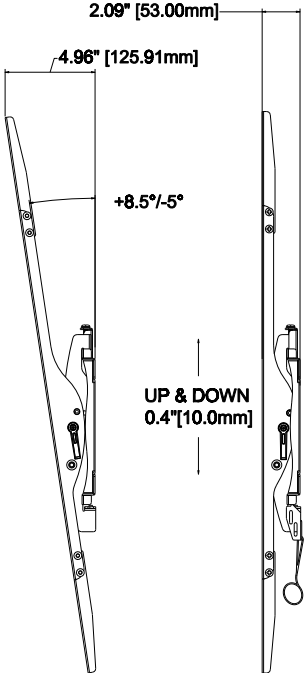
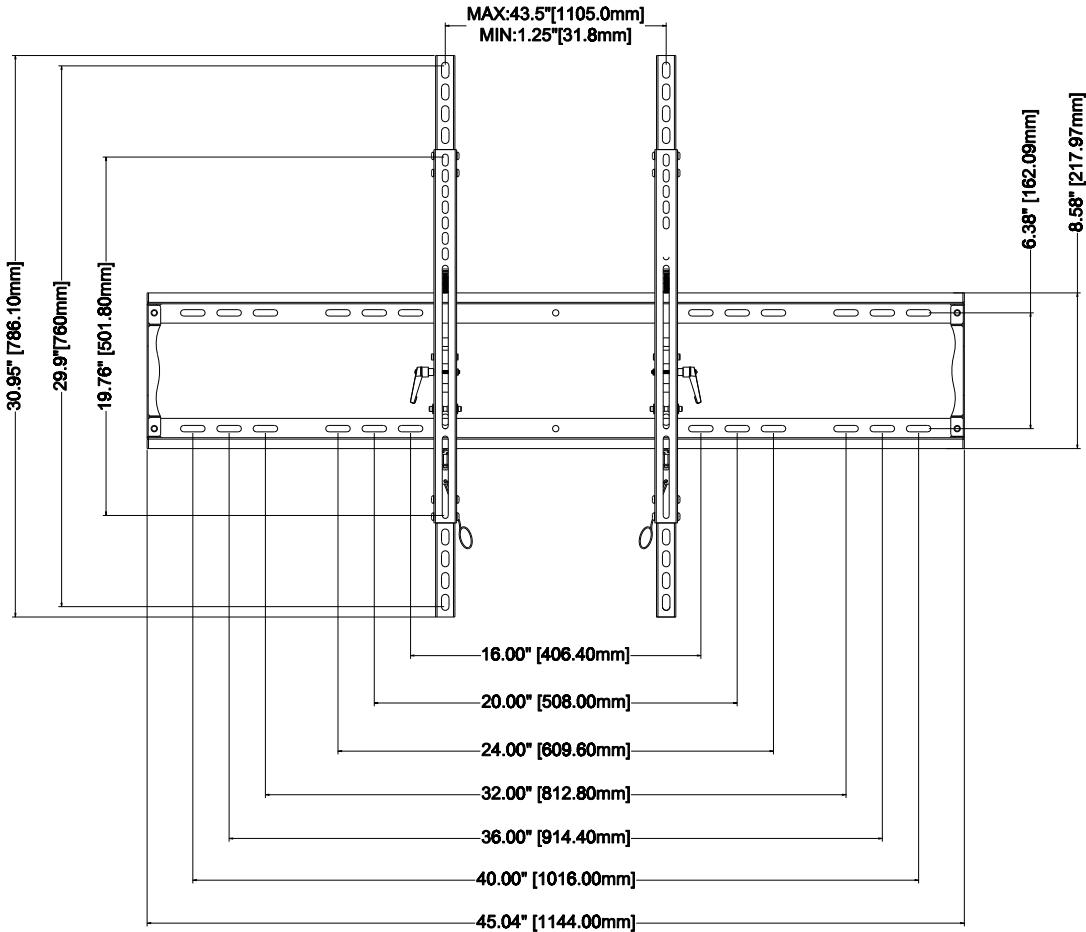

THE INFORMATION CONTAINED IN THIS DRAWING IS THE SOLE PROPERTY OF CRIMSON AV LLC. ANY REPRODUCTION IN PART OR AS A WHOLE WITHOUT THE WRITTEN PERMISSION OF CRIMSON AV LLC IS PROHIBITED

CRIMSON AV LLC.
PRODUCT ORDER NUMBER: RST90
PHONE: 1-866-668-6888

Scale=1:1

Crimson AV LLC. www.crimsonav.com	
TITLE: RST90	
SIZE B	DWG.NO. RST90