



205 Westwood Ave, Long Branch, NJ 07740
Phone: 866-94 BOARDS (26273) / (732)-222-1511
Fax: (732)-222-7088 | E-mail: sales@touchboards.com



ActivBoard 100

THIS DOCUMENT CONTAINS SPECIFICATIONS FOR

ActivBoard

DESCRIPTION

The ActivBoard 100 with Single-User technology (optional Dual-User upgrade) is available in 64" and 78"* versions. *Available in selected markets.

SYSTEM OVERVIEW

Installation

The installation of this product should be completed by a Promethean Certified Installer. Please visit www.PrometheanWorld.com/ActivCare/installationtc. Components supplied and minimum specifications stated have been tested and are required for optimal performance. Use of components not supplied by Promethean or not meeting minimum specifications may impact performance and affect warranty. Contact your Promethean partner or visit www.PrometheanKB.com for more information

Warranty

For Promethean Warranty Information please visit: www.PrometheanWorld.com/ActivCare

Support

Online Support for all Promethean Products available from: www.PrometheanKB.com

UPGRADE AND ACCESSORY OPTIONS

Wireless Upgrade Pack 100

Allows the ActivBoard 100 to connect to the computer wirelessly; includes an ActivHub (2.4 GHz), PSU (Power Supply Unit) and Quick Start Guide

Cable Wall Box

Connectivity box with inputs for 2 x fully wired VGA (to support VESA DDC) plus 3.5mm stereo jack audio inputs, USB-B input (for ActivBoard), S-Video, composite video plus auxiliary audio jack inputs, Cat 5e Ethernet input. Allows additional flexibility during installation, where the computer is located further away from the System

ActivArena 50 Upgrade Pack

Allows 2 users to work on the ActivBoard simultaneously; includes 2 Instructor and 2 Participant ActivPens, ActivArena Resources CD, ActivArena paper license, and ActivArena Quick Start Guide (requires ActivInspire Professional Edition)

ActivWand 50

Wireless, battery-free and extended reach input device for the ActivBoard – 540mm (21.2in) in length; "left click", cursor and hover, just like a mouse

ActivInspire Professional Edition

ActivInspire Professional Edition, proving additional features and functionality

ActivBoard Systems/Boards SS 11/11 V2.0 US

©2011 Promethean Limited. All rights reserved. Promethean Ltd. is owner of a number of trademarks in several jurisdictions across the world. Any third-party product and company names are mentioned for identification purposes only and may be trademarks of their respective owners. ¹Applicable Terms and Conditions for warranty and support available at www.PrometheanWorld.com/ActivCare. All dimensions +/- 5mm (0.2in). All weights +/- 0.9kg (2lb). Product Specifications are subject to change without notice. www.PrometheanWorld.com

TECHNICAL DRAWING SPECIFICATIONS

ActivBoard 164

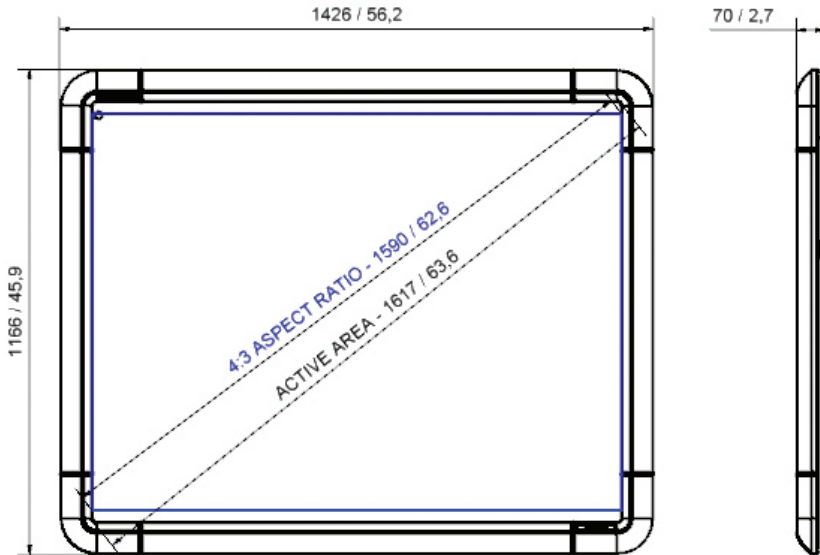

ActivBoard 178

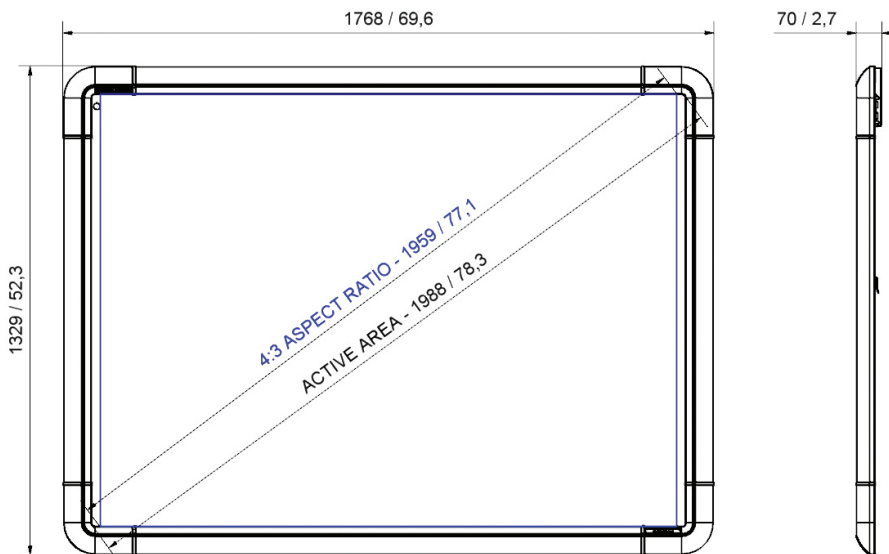

ActivBoard Systems/Boards SS 11/11 V2.0 US

©2011 Promethean Limited. All rights reserved. Promethean Ltd. is owner of a number of trademarks in several jurisdictions across the world. Any third-party product and company names are mentioned for identification purposes only and may be trademarks of their respective owners. ¹Applicable Terms and Conditions for warranty and support available at www.PrometheanWorld.com/ActivCare. All dimensions +/- 5mm (0.2in). All weights +/- 0.9kg (2lb). Product Specifications are subject to change without notice. www.PrometheanWorld.com

ACTIVBOARD GENERAL SPECIFICATIONS

Internal Resolution	2730 points (lines) per inch
Output Resolution	200 points (lines) per inch
Tracking Rate	200 inches per second providing a fast response to pen commands
Output Rate	120 coordinate pairs per second
User Input	Cordless battery-free pen incorporating tip switch and side switch for full mouse functionality (ActivPen)
Digitizing Technology	Passive Electromagnetic
Power Requirement	Mains Powered: 18V Power Supply Unit
Connection to Computer	USB 2.0, 1 x 5m USB data cable supplied
Screen Surface	Low Glare Melamine
Screen Format	4:3
Certifications	UL, CE, FCC
Operating Temperature	0°C to +50°C (14°F to +122°F)
Storage Temperature	-20°C to +70°C (-4°F to +158°F)
Storage Humidity	0% to 90% (non condensing)
Packed Contents List	ActivBoard, 2 ActivPens (Instructor), 5m (16ft) USB cable, Wall Mounting Brackets, Installation Guide, Access to ActivInspire Personal Edition via download from Promethean Planet (Also available on DVD on request)

ACTIVBOARD SPECIFICATIONS BY MODEL

Model	ActivBoard 164	ActivBoard 178
Activboard Size	64in	78in
Surface Area Resolution	10000 x 8000	12800 x 9200
Active Area Dimension	1271mm x 1012mm (50in x 40in)	1614mm x 1175mm (64in x 46in)
Active Area Diagonal	1617mm (63.6in)	1988mm (78.3in)
Actual Image Diagonal (4:3)	1590mm (62.6in)	1959mm (77.1in)
Overall Dimension	1426mm x 1166mm (56.2in x 45.9in)	1768mm x 1329mm (69.6in x 52.3in)
Board Weight	18kg (39.7lb)	25kg (55.1lb)
Packed Weight	30kg (66.1lb)	39kg (92.6lb)
Packed Dimensions	1580mm x 1330mm x 110mm (62.6in x 52.6in x 4.3in)	1920mm x 1500mm x 110mm (75.6in x 58.9in x 4.3in)

ActivBoard Systems/Boards SS 11/11 V2.0 US

©2011 Promethean Limited. All rights reserved. Promethean Ltd. is owner of a number of trademarks in several jurisdictions across the world. Any third-party product and company names are mentioned for identification purposes only and may be trademarks of their respective owners. ¹Applicable Terms and Conditions for warranty and support available at www.PrometheanWorld.com/ActivCare. All dimensions +/- 5mm (0.2in). All weights +/- 0.9kg (2lb). Product Specifications are subject to change without notice. www.PrometheanWorld.com

MINIMUM SYSTEM REQUIREMENTS

Operating Systems	Windows XP SP3 and above (XP/Vista/7); Mac OSX 10.4.11 – 10.6.4 (Tiger/Leopard/Snow Leopard); Linux Ubuntu 9.10 or 10.04; Debian Lenny; Linex Colegios 2010; Linkat 3; ALT_Linux
PC	2.0 GHz Intel Core 2 Duo or faster for HD-quality videos, 1 GB of RAM is required to play HD-quality videos, 1024 x 768 resolution, 1.5 GB of free disk space
Mac	2.0 GHz Intel Core 2 Duo, 512 MB of RAM, 1024 x 768 resolution, 3.0 GB of free disk space



205 Westwood Ave, Long Branch, NJ 07740
Phone: 866-94 BOARDS (26273) / (732)-222-1511
Fax: (732)-222-7088 | E-mail: sales@touchboards.com