



Additel 949

Hydraulic Ultra-High Pressure Test Pump User's Manual

[Version number:1410V04]

Please download the latest version from www.additel.com



Warnings and cautions

- Operate the pump in the rated pressure range of 40,000 psi (2,800 bar) and do not exceed the safety pressure of 44,000 psi (3,080 bar).
- When the system pressure is greater than 10,000 psi, you must close the pre-pressurization shut off valve (#7) and then pressurize the system with the high pressure handle.
- Always tighten the gauges using two wrenches .
- Close all valves and handles and tighten the ports when transporting the pump.
- Always keep the reservoir cover vent valve (#4) open during operation.
- Do not over tighten the valves, connectors and handles to avoid damage.
- Change media immediately if it is contaminated.
- Keep media level between 1/4 and 3/4 of the liquid reservoir filled.
- Keep the threads clean and lubricious, and remove any dirt on threads.
- Used by trained personnel only.
- Additel is not liable for any safety problems or damages caused by misuse or incorrect operation.

Specification

- **Pressure range:** 12.5 psi (0.85 bar) vacuum to 40,000 psi (2,800 bar) positive pressure

*Remark: If local atmosphere pressure is 1 bar, the vacuum can reach to 0.85 bar;
If local atmosphere pressure is P, the vacuum can reach to (P - 85%) bar.*

- **Temperature:** (5 ~ 50) °C
- **Adjustment resolution:** 0.015 psi (1 mbar)
- **Safety pressure:** < 44,000 psi (3,080 bar)
- **Pressure media:** Diethylhexyl Sebacate
- **Size:** Height: 10.43" (265 mm)
Base: 20.71" (526 mm) x 9.65" (245 mm)
- **Weight:** 35.5 lb (16 kg)

Views and Hydraulic Schematic

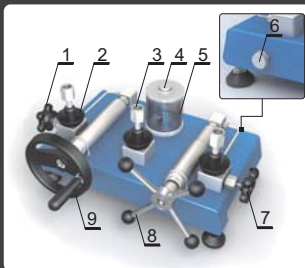

- 1- Vent valve
- 2- Over-flow reservoir
- 3- Positional Autoclave F-250-C, 9/16"-18UNF female
- 4- Reservoir cover vent valve
- 5- Reservoir
- 6- Liquid drain valve
- 7- Pre-pressure shut off valve (Isolates the calibration volume from the pre-presssure side of the pump)
- 8- High-presssure and fine adjustment handle
- 9- Pre-presssure handle

Hydraulic Schematic

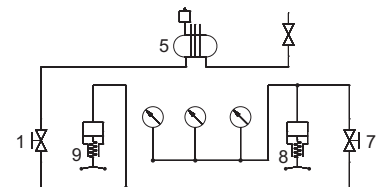

Troubleshooting

Problem	Cause	Solution	
It is difficult to generate pressure with the pre-presssure handle (#9)	Vent (#1) is not closed	Close vent valve (#1)	
	Pre-presssure shut off valve (#7) is closed	Open pre-presssure shut off valve (#7). Caution: the pre-presssure side of the pump should not be exposed to more than 10,000 psi (700 bar).	
	Not enough media is in the reservoir.	Fill more media, and keep media level between 1/4 and 3/4 of the liquid reservoir filled	
	Too much air is in the pump	Purge the air from the system (see Preparation section of the manual)	
It is difficult to pressurize by turning the high-presssure handle (#8)	Max pressure generation (could be as low as 5,000 psi, 350 bar) is achieved with the pre-presssure handle (#9)	Close pre-presssure shut off valve and use high-presssure and handle (#8).	
	The pre-presssure shut off valve (#7) is not closed completely	Close pre-presssure shut off valve (#7)	
It is difficult to generate high vacuum	Reference gauge or devices under test (DUTs) are not connected tightly	Check finger-tight connectors, re-tight if necessary	
	The connector of the DUT is not matched to connector	Use proper adapter	
Hard to pressurize large-volume DUT	Too much air is in the pump	Purge the air from the system (see Preparation section of the manual)	
	#4 valve is not open	Open the #4 valve	
	Because of the large volume of the DUT, it will take additional steps to fill the volume to pressurize the DUT		Step 1: Turn pre-presssure handle (#9) all the way in clockwise, close pre-presssure shut off valve (#7), open vent valve (#1).
			Step 2: Turn pre-presssure handle (#9) all the way counterclockwise, close vent valve (#1).
Pressure gauges do not reach to zero		Step 3: Open pre-presssure shut off valve (#7), pressurize the system.	
		Step 4: Repeat step 1 to 3.	
Hard to turn the valves or handles	#4 valve is not open	Open the #4 valve	
	Too much force was previously applied	Do not over tighten	
	Hard to turn pre-presssure handle (#9) at high pressure	This is normal. Close the pre-presssure shut off valve (#7) and use the high-presssure handle to adjust the pressure.	
	Lack of lubrication on threads	Lubricate the threads	

O-Rings for pressure connector

P/N	Size	Connector
1611300220	6.5X3	M20X1.5, 1/2BSP

Basic Operation

A

Note: ① Gauge positions are exchangeable. If only one device under test (DUT) is connected, the third connector on pump should be closed with a plug.
② Connect the gauges on pump and tighten the connectors using two wrenches.

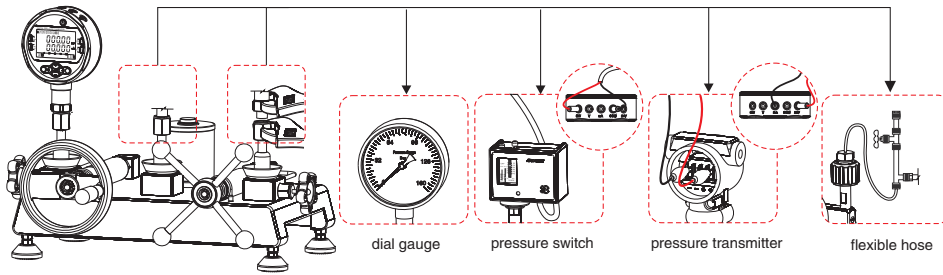

B

Purge process

⑤ Vacuum displayed on the gauge

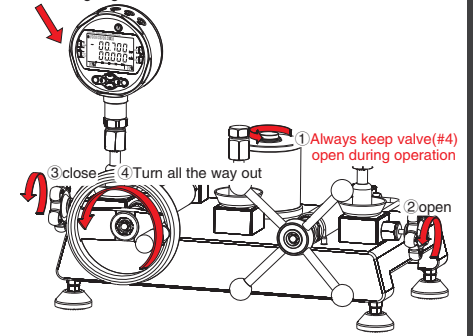

C

Purge process (cont.)

If air is still trapped in the pump, then repeat the purge process 2 or 3 more times until all the gas is removed from the system

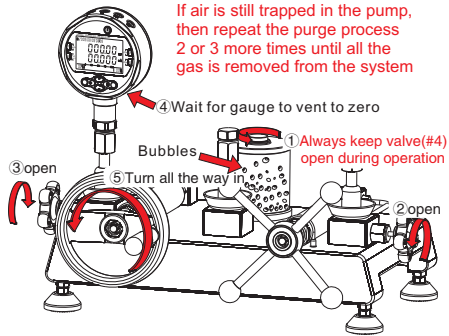

D

Zeroing

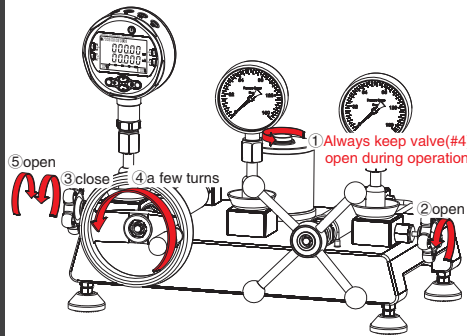

E

Pressurizing process

Note: Skip step ③ for dial gauge calibration in a narrow pressure range

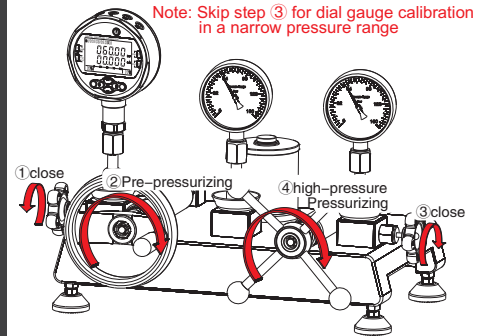

F

Depressurizing process

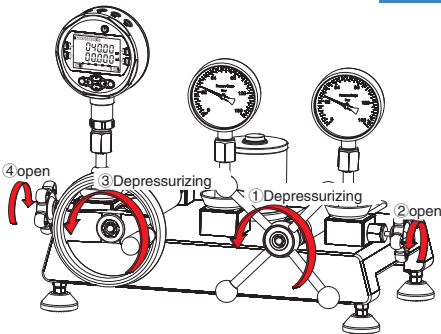

G

Vacuum process

If it is difficult to generate vacuum pressure, then repeat the purging process to make sure all the gas is removed from the system

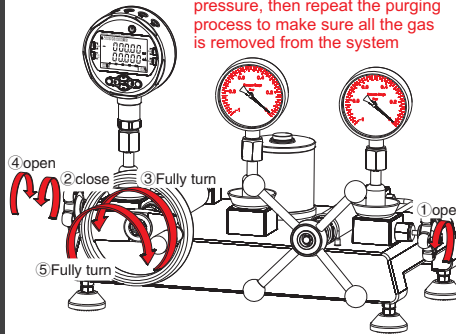

H

Vent

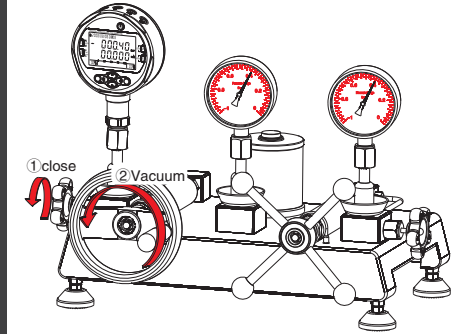

Maintenance

I

Back to atmosphere

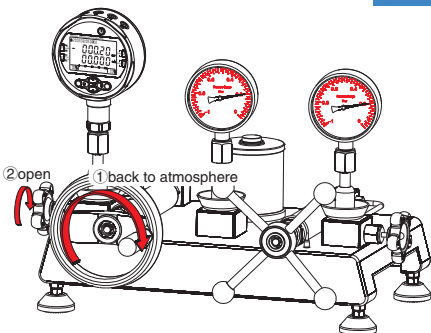

A

Fill media

Note: Please degas after filling media liquid, in case hard to generate pressure.

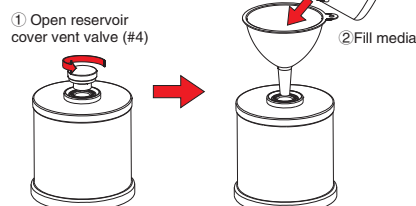

B

Drain and Clean

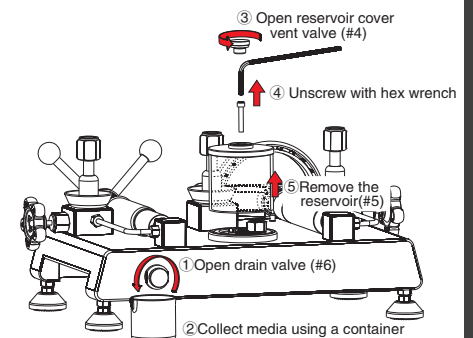

Remark:

A: Additel has made a concerted effort to provide complete and current information for the proper use of the equipment. The product specifications and other information contained this manual are subject to change without notice.

B: Above pictures are just for reference.