

Step 8

Install all six Caster Inserts into the Base Tube and secure with one Caster Screw per Insert.

Push the Casters, (locking ones in front) into the Caster Inserts.

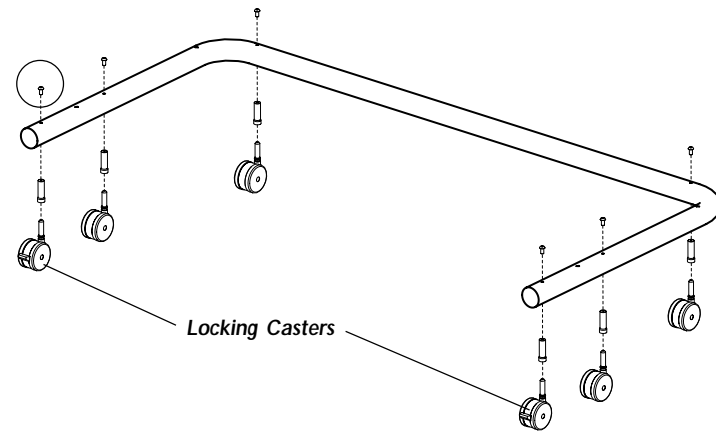

Step 9

Place the Base Tube Assembly (from Step 8) onto the Vertical Legs of the Shelf Assembly (from Step 7).

Attach the Base Tube to the Legs using a total of four Base Tube Screws.

TIGHTEN ALL SCREWS.

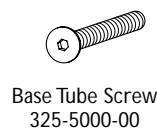
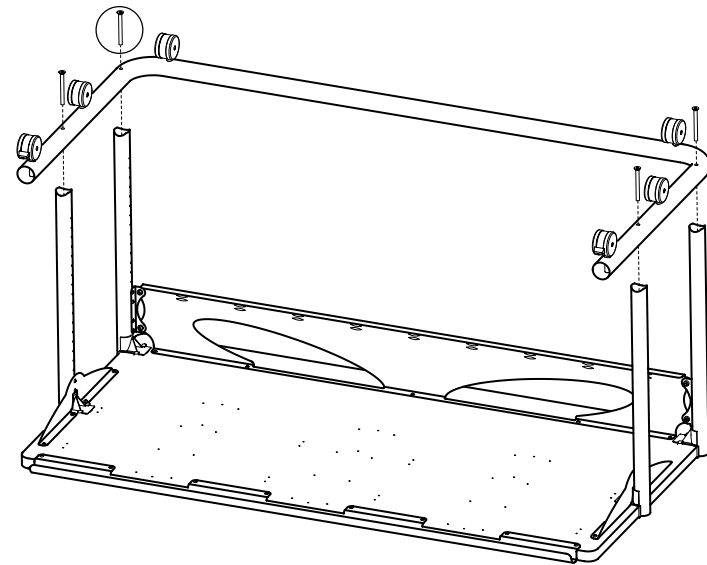

Step 10

Carefully, rotate your Cart over onto the Casters.

Pop the 1.5" Small End Caps into the Vertical Legs and the 1.75" Large End Caps into the Base Tube.

Congratulations! Your assembly is complete.

Please return the enclosed Registration Card to receive our product updates, new catalogs, and sale flyers.

Thank you for choosing Anthro!

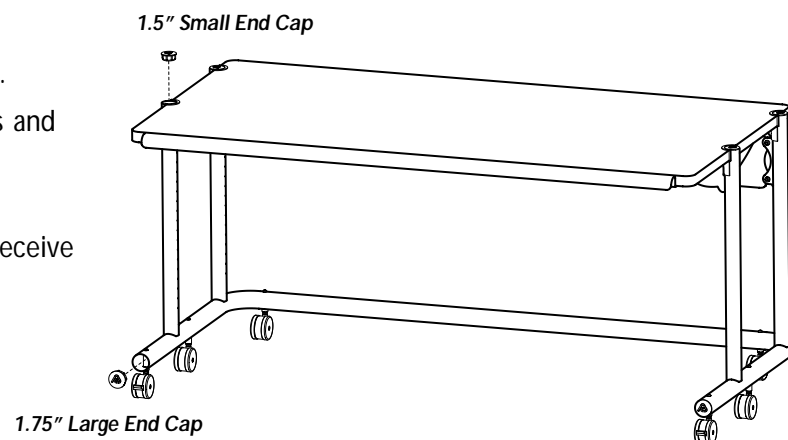

Questions?

1-800-325-3841

60" Wide AnthroCart

Assembly Instructions



These Assembly Instructions are for the H24xx & H25xx.

Before beginning assembly of your 60" Wide AnthroCart, please take a moment to review the parts listed below to verify that your shipment is complete.

✓ **Does your Cart have 4" Casters?***
(Such as an H24xx4. Your Caster Part Numbers are given here.)

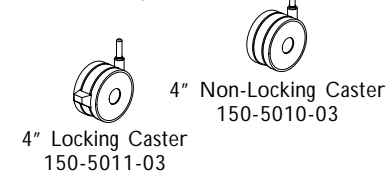

✓ **Does your Cart have Glides?***
(Such as an H24xxGL. Your Glide and Glide Insert Part Numbers are given here.)

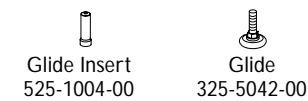

To make the assembly of your 60" Wide AnthroCart even easier, we have included all of the required tools. The handy Hex Driver Bit can be used in your electric drill in place of the Hex Driver.

Hex Driver $\frac{5}{32}$ " 375-5000-00
Hex Driver Bit $\frac{5}{32}$ " 375-5003-00
8 oz. Rubber Mallet 375-5022-00

Enclosed Parts List

Detailed views of all Hardware are provided with each Assembly Step.

01- Insert Screws Qty. 6 325-5052-00	13- Bracket Screws Qty. 4 325-5149-00
02- 1.75" Large End Caps Qty. 2 175-5021-xx	14- 4.75" Pan End Bracket Qty. 2 225-5344-xx
03- Caster Inserts Qty. 6 525-1000-00*	15- Clamp Screws Qty. 4 325-5086-00
04- 2 $\frac{3}{8}$ " Locking Casters Qty. 2 150-5003-03*	16- Shelf Supports Qty. 4 175-5060-xx
05- 2 $\frac{3}{8}$ " Non-Locking Castors Qty. 4 150-5002-03*	17- Shelf Clamps Qty. 4 175-5059-xx
06- Base Tube Screws Qty. 4 325-5000-00	18- 60" Wide Shelf Qty. 1 (see below)
07- 60" Wide Base Tube Qty. 1 (see below)	30" Deep Shelf (H24xx) 100-6337-xx
30" Deep Base Tube (H24xx) 125-5177-xx	36" Deep Shelf (H25xx) 100-6338-xx
36" Deep Base Tube (H25xx) 125-5178-xx	19- 1.5" Small End Caps Qty. 4 175-5020-xx
08- 23.875" Vertical Legs Qty. 4 125-5020-xx	20- 18" Bridge Side Gussets Qty. 2 225-5337-xx
09- $\frac{3}{4}$ " Wood Screws Qty. 21 325-5106-00	
10- 56" Handle Lip Qty. 1 225-5347-xx	
11- Support Screws Qty. 16 325-5010-00	
12- 58" Wide Bridge Pan Qty. 1 225-5341-xx	

All Fastener quantities listed here are the minimum needed for your Cart assembly. There may be a few extra Fasteners included, which are not counted in the Parts List.

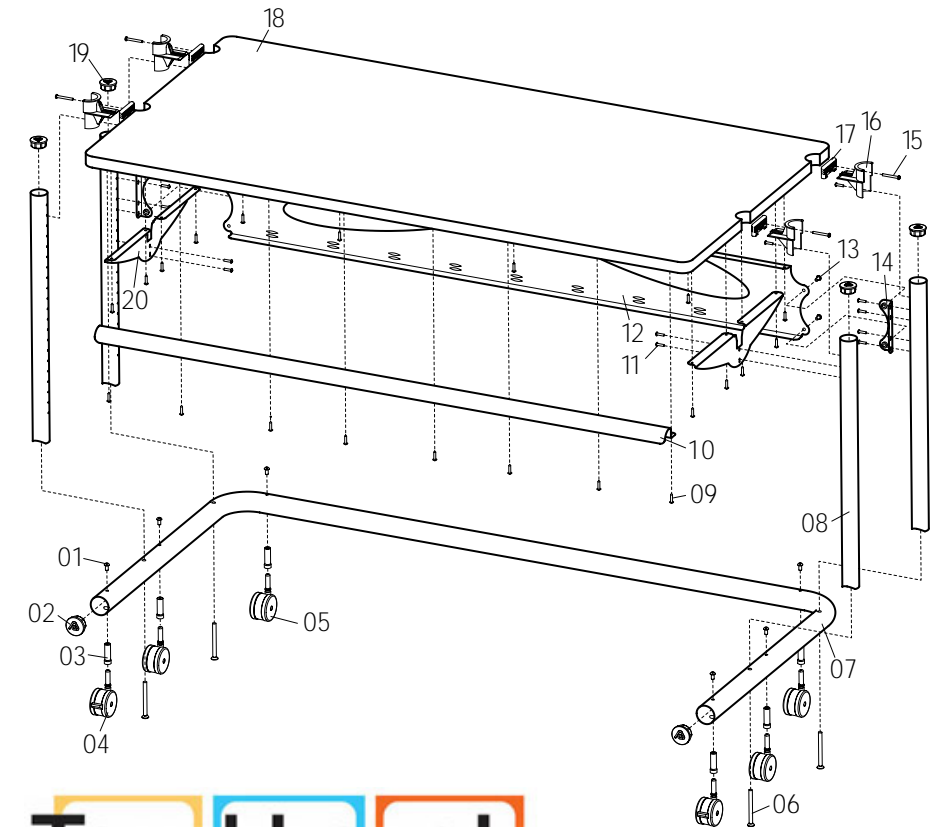

Touchboards

205 Westwood Ave, Long Branch, NJ 07740
Phone: 866-94 BOARDS (26273) / (732)-222-1511
Fax: (732)-222-7088 | E-mail: sales@touchboards.com

60" Wide AnthroCart

Assembly Instructions

Questions? 1-800-325-3841

Step 1

These Instructions will cover both the H24xx & H25xx 60" Wide AnthroCart assembly. Before proceeding, please review the Assembly Instructions of all Anthro Products you purchased and are planning to include in this installation.

These instructions will place your Shelf 28" from the floor using the standard 2 3/8" Casters.

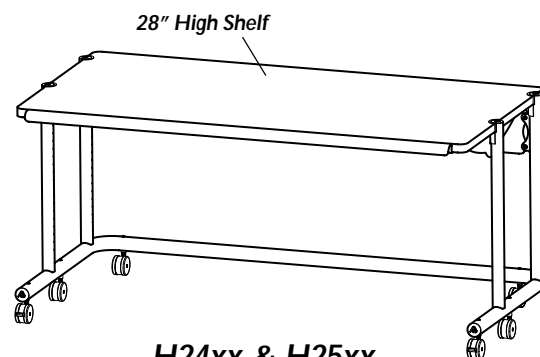

H24xx & H25xx
60" Wide AnthroCart shown with 2 3/8" Casters
Add 1" to overall height for 4" Casters
Subtract 3" from the overall height for Glides

Step 2

Determine the best height for your Shelf. Generally, a 28" high work surface works well for most people and equipment.

For a final Shelf height that is higher or lower than 28", refer to the illustration shown at right to determine which holes to attach your Shelf.

Your Shelf locations may be changed after your Cart has been completely assembled by repeating Steps 5 & 6.

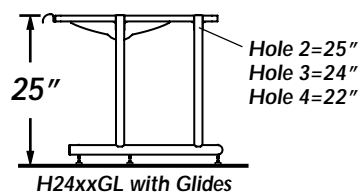
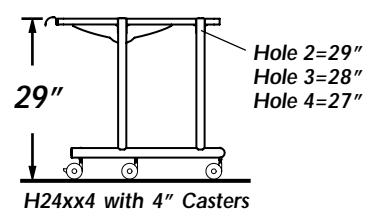
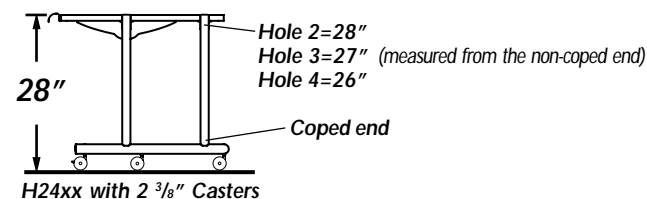

Step 3

Attach all four Shelf Supports to the Shelf.

Begin by first installing a Shelf Clamp into the Shelf notch. Be sure the pointed Barbs face towards the outer Shelf edge.

Next, slide a Shelf Support into the recesses of the Shelf Clamp and Shelf. Push in as far as possible.

Finally, secure with a Clamp Screw.

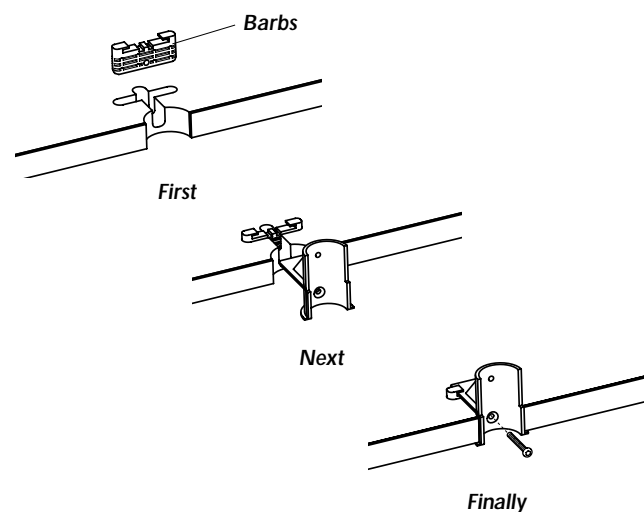

Step 4

Position both Bridge Side Gussets onto the Shelf underside as shown. Align the predrilled holes on the underside of the Shelf with those on the Gussets and secure into place using a total of four Wood Screws per Gusset.

Next, place the 56" Lip onto the front of the Shelf, aligning the predrilled Holes of the Lip with those on the front of the Shelf. Secure the Lip using a total of eight Wood Screws.

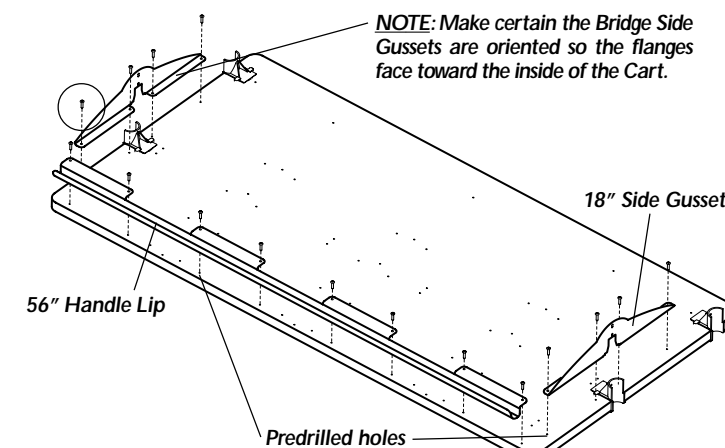

Step 5

Attach the front Vertical Legs by loosely installing one Support Screw through a front Shelf Support into Hole 2 from the top (non-coped end) of a Leg.

Next, loosely install two Support Screws through a Side Gusset into a corresponding Leg.

Repeat for remaining front Vertical Leg and Side Gusset.

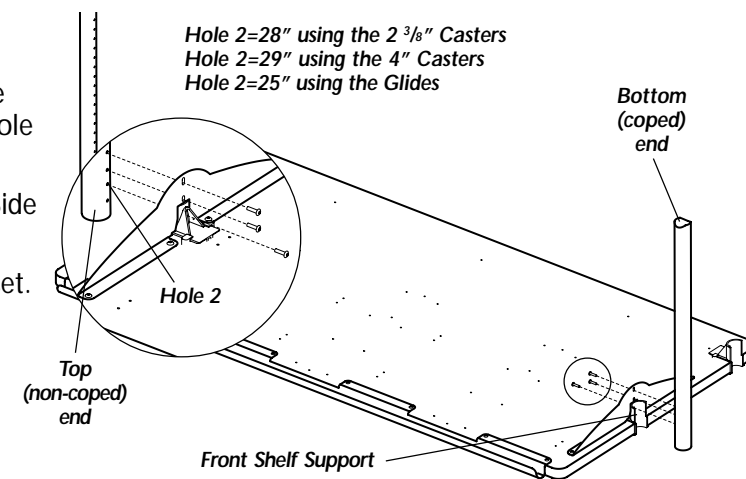

Step 6

Attach the rear Vertical Legs by loosely installing one Support Screw through the rear Shelf Supports into Hole 2 of each Leg.

Next, position a Pan End Bracket against a rear Vertical Leg. Secure into place by loosely installing four Support Screws through the Bracket into Holes 3, 4, 6 & 7 from the top of a rear Leg. Repeat for remaining Pan End Bracket.

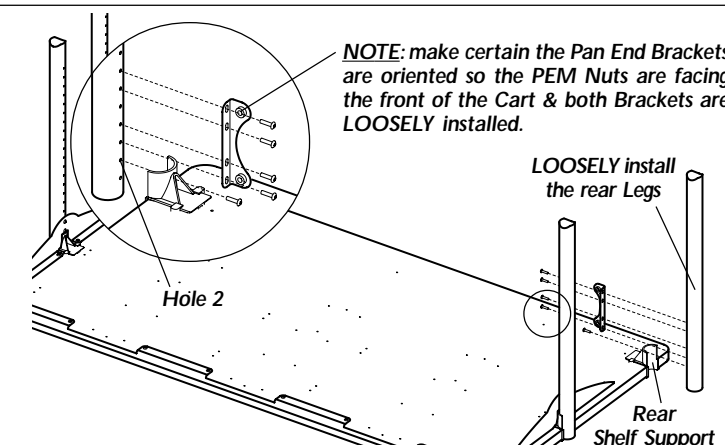

Step 7

Place the Bridge Pan onto the Shelf between the rear Vertical Legs. Secure the Pan to the Shelf by first installing five Wood Screws through the Pan flange into the Shelf.

Next, insert a Bracket Screw from the rear of the Cart through the Pan and carefully thread into a Pan End Bracket. Finally, repeat for the remaining Bracket Screws and Pan End Bracket.

