

# STEVE'S STATION®



The Steve's Station family of advanced sit/stand furniture keeps you comfortable and productive all day long, all while lifting up to 325 lbs. with a height range of 23"-49" high. **Steve's Station for Imaging** was developed in partnership with radiologists nationwide to meet their specific ergonomic needs.

The table's Monitor Easy Track® moves the entire bank of monitors forward and back 10" to reach your optimal focal depth.

Steve's Station's innovative design and usability earned it NeoCon's 2011 Innovation Award from industry leaders in product design.

## PRODUCT SPECIFICATIONS

**Shelves:** 1" thick medium-density fiberboard shelves are wrapped in a highly durable thermoplastic laminate to resist cracking and stand up to a wide range of chemicals.

**Metal:** Metal components are 16 gauge steel with a baked-on powder coat finish.

**Colors:** See Color Choices at the top of the following pages for available colors.

**Tested for safety:** Steve's Station is ETL-listed to UL standard 60950-1 in US and Canada.

**Warranty:** Lifetime Warranty against manufacturing defects on the table; 5-year warranty on legs and electrical system. Lamps, cords, and plugs are not warranted.



NEW! Steve's Station Essential.  
(72 wide shown above.)

## STEVE'S STATION WORKSTATIONS

**NEW! STEVE'S STATION ESSENTIAL – ALL THE ESSENTIAL YOU NEED, AT A VERY COMPETITIVE PRICE**



72 W STEVE'S STATION ESSENTIAL  
RAD260GV-WE

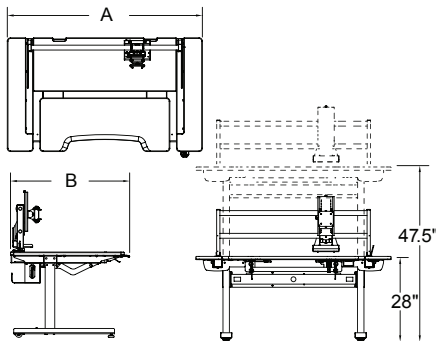

- Available in two widths: 60" and 72". Tables measure 35" deep.
- Electric lift legs adjust the table's height 28"-47.5" high with the push of a button. Strong legs move 0.9"/sec.
- Front keyboard surface adjusts 5.75" below the rear monitor surface to 7" above for a total height range of 22.25"-54.5". Loosen the knobs to adjust the tilt from 9 degrees forward for positive tilt to 15 degrees back for negative tilt.
- Keyboard surface measures 40" wide x 16.25" deep. Keyboard surface tapers in at the center to 12.5" deep for a cockpit feel.
- Side shelves measure 8" wide on the 60w table and 14" wide on the 72w table.
- Total lift capacity 200 lbs including up to 40 lbs on the keyboard surface.
- Table includes updated Monitor Easy Track™, a monitor management system that slides the entire monitor array forward and back in unison to reach your optimal focal depth (10" range).
- Monitor Easy Track also fine-tunes each monitor's position vertically, laterally, and side-to-side tilt to place your displays in a seamless array, even different sizes and makes.
- Monitor Easy Track comes with a central monitor boom (45.25" long) and a single monitor knuckle. Choose from four pre-configured kits to expand your table to support your modality. Kits available in 2+1, 4+1, and versions for large dual-width imaging displays. Monitor knuckles and side Monitor Extensions are also sold separately.
- Each knuckle comes with a 15-ft DVI-D cable to route from your display, through the table's cable trough, and to your computer. Routing your power and data cables through the system ensures that equipment stays connected through the table's entire range of motion, without disconnecting or damaging the ports. This cable is capable of transmitting resolution value of 2560x1600 at 60 hz.
- Cable trough measures 43.5"w x 8.75"d x 8.5"h to hold all your cords and cables. Add a Power Bar (sold separately) to plug in all your devices plus the table and send a single power cord to the wall. This protects power connections on your equipment as the table moves up and down.
- "Tilt and go" wheels at the back of each foot make it easy to move the table when you need to rearrange your reading room or access the back of your equipment. Just lift the table on the side shelves and roll the table into place!
- Available in Grey Metallic metal with Silver Satin accent (GV) with choice of Dark Grey (DG) and Wenge (WE) laminate.
- Comes with 1" thick worksurface with thermoplastic laminate finish, Monitor Easy Track with 10" depth adjustment, two electric lift leg assemblies, one keyboard surface with manual height and tilt control, one cable trough, two feet with tilt-and-go back wheels.
- Listed to UL 962 and CSA C22.2 No. 68 for safety. Ships in two boxes.



205 Westwood Ave, Long Branch, NJ 07740  
Phone: 866-94 BOARDS (26273) / (732)-222-1511  
Fax: (732)-222-7088 | E-mail: sales@touchboards.com

PRODUCT	Width (A)	Depth (B)	Weight	Part #	Price
60"w Table	60"	35"	268 lbs.	RAD260GV-zz	\$4,599
72"w Table	72"	35"	282 lbs.	RAD272GV-zz	\$4,995

01/15

**QS** Quick Ship items usually ship within 1-3 business days.

"We have at least 10 radiologist that use Steve's Station and they couldn't be happier! The features that are most used are – ambient light, table height adjustment, USB port, monitor adjustment, fan and task lights."

—Dr. Deborah Arnold, Radiologist, Providence Medical Center



## NEW! STEVE'S STATION ADVANCED



STEVE'S STATION ADVANCED  
DUAL SURFACE, 72\"/>

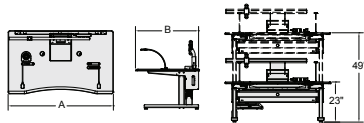

STEVE'S STATION ADVANCED  
SINGLE SURFACE

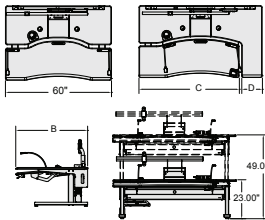

STEVE'S STATION ADVANCED  
DUAL SURFACE

- Radiology reading station comes with Monitor Easy Track, a monitor management system that slides the entire monitor array forward and back in unison to place displays at your optimal focal depth (10" range).
- Customize Monitor Easy Track to support your particular modality. Add knuckles to support each display, and Monitor Boom Extensions to extend the width of the monitor boom. Monitor Easy Track supports up to 130 lbs total.
- Monitor Easy Track also fine-tunes each monitor's position vertically, laterally, and side-to-side tilt to place your displays in a seamless array, even different sizes and makes.
- Comes with a central monitor boom (44" long) and a single monitor knuckle. Choose from four pre-configured kits to expand your table to support your modality. Kits available in 2+1, 4+1, and versions for large dual-width imaging displays. Monitor knuckles and side Monitor Extensions are also sold separately.
- Each knuckle comes with a 15-ft DVI-D cable to route from your display, through the table's cable trough, and to your computer. Routing your power and data cables through the system ensures that equipment stays connected through the table's entire range of motion, without disconnecting or damaging the ports. This cable is capable of transmitting resolution value of 2560x1600 at 60 hz.
- Electric legs adjust the table's height 23"-49" high with the push of a button. Strong legs move 0.9"/second.
- Available in single-surface and dual-surface versions. Dual-surface table features front keyboard surface with manual height and tilt adjustment. Adjust height 5.75" below to 7" above the back monitor surface for a total height range of 17.25"-56". Keyboard surface tilts 9 degrees forward, for positive tilt, to 15 degrees back, for negative tilt.
- Twin LED task lights (one left, one right) are on flexible 12" gooseneck arms, so you target the light where it's needed. On/off switch and dimmer give you control.
- Safety limit switches stop the table's motion when the worksurface encounters an obstacle.
- Air circulation fans keep air moving around the displays so you stay fresh. Fan housing pivots, so you direct the air as needed, and dimmer lets you control the flow.
- Overall weight and lift capacity is 325 lbs.
- Ships assembled in a single palletized package.
- Available in Grey Metallic metal with Silver Satin accent (GV) and Dark Grey (DG), Maple (MP), or Wenge (WE) laminate.
- Comes with 1" thick worksurface with thermoplastic laminate finish, updated Monitor Easy Track with 10" depth adjustment on twin-beam boom assembly, two shelf support arms with safety stops, two electric lift leg assemblies, power strip on worksurface with 3 outlets, two LCD task lights with dimmer control, air circulation fan, cable trough, power strip in cable trough with 12 outlets, two cable management ladders (one on monitor support assembly, one under cable trough), two feet with leveling glides, and one power cord.

PRODUCT	Width (A)	Depth (B)	Width (C)	Width (D)	Weight	Part#	Price
Single-surface, 60"w	60"	36"	-	-	357 lbs.	STB160zz/xx	\$5,999
Single-surface, 72"w	72"	36"	-	-	372 lbs.	STB172zz/xx	\$6,199
Dual-surface, 60"w	60"	42.5"	-	-	369 lbs.	STB260zz/xx	\$6,499
Dual-surface, 72"w	72"	42.5"	58.5"	12"	384 lbs.	STB272zz/xx	\$6,599

## COLOR CHOICES

Select your product colors from the following swatches. Replace "xx" with a 2-letter Laminate Code.



Metal Colors (GV)



Laminate Colors (xx)

## STEVE'S STATION ACCESSORIES

### CPU SIDERACKS

Install your CPU in a SideRack and save space on your Steve's Station! Choose the size and style that fits. Available in Grey Metallic with Silver Satin accent.

#### CPU SideRack, Inboard

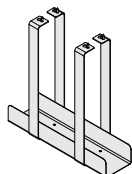

- Attaches under the worksurface of your Steve's Station table with four screws. Installs left or right.
- Supports CPUs up to 4" wide, 15.5" high. Holds up to 40 lbs.
- Comes in Grey Metallic with Silver Satin accent.

PRODUCT	Width	Depth	Height	Weight	Part #	Price
CPU SideRack, Inboard	4"	16"	15.5"	6 lbs.	STSR1GV	\$79.95

#### CPU SideRack, Outboard

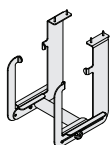

- Attaches to the outside edge of your Steve's Station table with four screws. Installs left or right.
- Slide the arms open to insert your CPU, then tighten down to keep it in place. Measure the width of your CPU and add 3" to determine how far the SideRack will extend from the side of your table.
- Supports CPUs 4.5"-9.75" wide. Holds up to 40 lbs.
- Comes in Grey Metallic.

PRODUCT	Width	Depth	Height	Weight	Part #	Price
CPU SideRack, Outboard	6.25"	11.5"	14.5"	12 lbs.	STSR2GM	\$179.95

#### CPU SideRack, Floor-mount

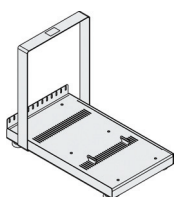

- This large 3" high platform sits on the floor to hold your CPU, UPS, or other equipment. Straddles either Steve's Station foot (left or right), or set it outside the footprint of the table.
- Metal hoop above the SideRack measures 16.25" above the platform to show the safe height limit of items stored under the table at its lowest position.
- Platform measures 13.25" wide, 22.5" deep. Comes with slots and strap and buckle kit to hold items in place.
- Did you add casters to your Steve's Station table? Add casters to this floor-mount too. Sold separately, part #570CA.
- Holds up to 125 lbs.
- Comes in Grey Metallic with Silver Satin accent.

PRODUCT	Width	Depth	Height	Weight	Part #	Price
CPU SideRack, Floor-mount	13.25"	22.5"	19.25"	20 lbs.	STSR3GV	\$209.95

### 3" CASTERS

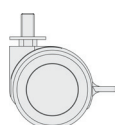

- Make your Steve's Station mobile with this set of four 3" casters. Also works with the CPU SideRack, Floor-mount.
- Casters make the station 3" higher. When using these casters with the Advanced or Deluxe Steve's Station, update the height adjustment readout with its instruction in the owner's manual.
- Total-lock casters feature polyurethane tires suitable for all floors.

PRODUCT	Weight	Part #	Price
Casters, set of 4	6 lbs.	570CA	\$139.95

### FILE AROUND

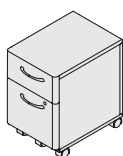

- Full-extension glides put everything in easy reach. Two locking casters keep unit in place when drawers are pulled out, and the fifth caster under the file drawer prevents the unit from tipping when drawers are fully extended.
- Holds up to 150 lbs. of distributed weight overall: up to 50 lbs. on top, up to 50 lbs. in the 6" drawer, and up to 75 lbs. in the 11" drawer.
- Available in Grey Metallic with Silver Satin accents.

PRODUCT	Weight Capacity	Locking	Width	Depth	Height	Weight	Part #	Price
FileAround	150 lbs.	Yes	15.5"	18.5"	21.5"	60 lbs.	510SM	\$699.95

## WHO IS STEVE?

Meet Steve Linder, Anthro's Senior Industrial Designer who created the original design language for Steve's Station.



## ELLIPTICAL TRAINER

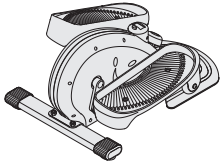

- Keep moving at your desk – without leaving your space or interrupting your work. Slide your feet into this Elliptical Trainer and start stepping. Move forward, backward, and even pause as you set your own pace.
- Use sitting or standing. Portable unit even tucks out of the way when not in use.
- Turn the Tension Knob to increase or decrease the resistance and set the intensity level.
- Electronic fitness monitor displays the number of strides per minute, the total number of strides, exercise time, and calories burned.
- Footprint is a space-saving 12" wide, 20" deep. Weight on this product should not exceed 250 lbs.
- Comes in Black with Silver accents. Ninety-day warranty against manufacturing defects.

PRODUCT	Width	Depth	Weight	Part #	Price
Elliptical Trainer	12"	20"	24 lbs.	MVELLBK	\$119.95*

## FLAT PANEL MONITOR SOLUTIONS

Lots of choices for your flat panel monitor! Pick the features you need. **Note: all mounting options conform to VESA 75mm and 100mm mounting standards.** If you need a different standard or would like to discuss additional monitor solutions that we have available, give us a call.

## Flat Panel Monitor Arm

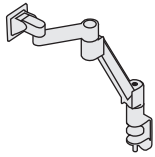

- These steel arms have a vertical travel range of 16" and rotate 360°. Travel range depends on the size of your monitor.
- Mount with either a C-clamp to the edge of your Bench or drill through a shelf for added security. Clamp opens a maximum of 2" and requires 3.5" of vertical clearance below the shelf.
- The Single Arms extend up to 22" from their mounting point.
- The Single Extra Heavy-duty Arm comes with a 100mm and a 100x200mm VESA plate.
- Ten-year warranty against manufacturing defects.
- The Single-Super and Single-Standard Arms are available in Black (BK) and Silver Metallic (SM). The Single-Extra Heavy-duty arm is available in Black (BK).

PRODUCT	Supports Monitors Weighing	Weight	Part #	Price
Single - Standard	7.5-25 lbs.	20 lbs.	LCDxx	\$399
Single - Super	13.5-44 lbs.	20 lbs.	LCD2xx	\$499
Single - Extra Heavy-duty	36-39 lbs.	25 lbs.	LCDXBK	\$1419

 QuickShip available for Standard and Super arms only.

## FOOTREST



- Elevate your feet with this simple footrest and alleviate pressure on your lower back. Rocking motion keeps your lower legs and feet moving while seated.
- Non-skid pads on the surface keep your feet in place.
- Measures 16.75"w x 12.25"d x 4.5"h.
- Comes in Black.

PRODUCT	Weight	Part #	Price
Footrest	5 lbs.	729BK	\$99.95*

## COLOR CHOICES

Select your product colors from the following swatches. Replace "xx" with a 2-letter Laminate Code.



Metal Colors (GV)



Laminate Colors (xx)

## MONITOR EASY TRACK OPTIONS – MONITOR SOLUTIONS

Steve's Station Advanced, Steve's Station Essential, and the Monitor Easy Track stand-alone unit share the dual-boom design. Customize the table to fit your modality with additional monitor knuckles, and increase the width of the array with articulating boom extensions.

### Monitor Easy Track Knuckles

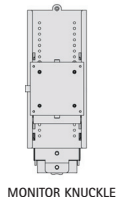

MONITOR KNUCKLE



MONITOR VERTICAL EXTENSION

- Choose from Standard and Super Knuckle based on the weight of your display. Knuckles work with updated dual-boom Monitor Easy Track products like Steve's Station Essential. Knuckles slide into the monitor track and rest on the monitor block which adjusts in height in 1" increments. The monitor track attaches to the boom or boom extension at any position horizontally. Reposition the track's lateral position easily by loosening a single knob.
- Each knuckle provides tilt and swivel adjustment.
- The Standard knuckle (RADKNABK) supports displays up to 35 lbs and comes with VESA 75mm and 100mm pattern. The knuckle slides into the monitor track with 7" height adjustment in 1" increments. Fine tune the monitors' height and yaw using a pair of screws.
- For larger displays weighing 25-60 lbs, choose the Super knuckle (RADKNBBK). This knuckle also slides into the monitor track with 5" height adjustment in 1" increments and fine-tune adjustment for height and yaw.
- Need to stack two standard displays for your RIS, dictation, or other system? Add the Monitor Easy Track Vertical Extension (RADMVBK). It installs on the center boom or on a Monitor Extension and comes with two knuckles. Supports two displays, one above the other, up to 35 lbs total and up to 17" apart, center to center.
- Each table and Monitor Easy Track appliance comes with one Standard Knuckle. Add additional to support your modality.
- Each knuckle comes with a 15-ft DVI-D cable to route from your display, through the table's cable management system, and to your computer. At 15 feet long, it reaches all the way from your display to your CPU no matter how you adjust the Monitor Easy Track so connections on both your display and your CPU are protected. Cable is capable of transmitting resolution value of 2560x1600 at 60 hz.

PRODUCT	Weight Capacity	Weight	Part #	Price
Standard Monitor Easy Track Knuckle	35 lbs.	10 lbs.	RADKNABK	\$229.95
Super Monitor Easy Track Knuckle	25-60 lbs.	12 lbs.	RADKNBBK	\$319.95
Monitor Easy Track Vertical Extension	35 lbs.	16 lbs.	RADMVBK	\$419.95

### Monitor Easy Track Boom Extension

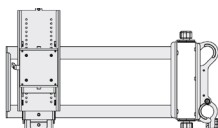

- Add more displays to your Monitor Easy Track with this Extension! Installs on the end of the center boom (or add one to each end) and measures 20" wide. Supports 35 lbs. Position extensions so they extend straight off the end of the boom or angle them toward you for a cockpit feel.
- Comes with a single knuckle plus hardware to attach the extension to your table or Monitor Easy Track appliance. Add more as space allows.

PRODUCT	Weight Capacity	Width	Weight	Part #	Price
Monitor Extension	35 lbs.	20"	19 lbs.	RADMEBK	\$319.95

### Monitor Easy Track Kits



4+1 CONFIGURATION



LD+1 CONFIGURATION

- Need to support a standard modality? Choose a pre-configured kit to make it simple! Available for 2+1 and 4+1 modalities plus corresponding modalities using double-wide Large Displays.
- The 2+1 modality kit includes one Monitor Extension (which includes one Standard knuckle) plus an additional Standard Knuckle to add a second display to the center boom. The single Monitor Extension supports 35 lbs.
- The 4+1 modality kit comes with two Monitor Extensions (each with one Standard knuckle) plus two additional Standard Knuckles. These go with the single Standard knuckle that comes on the center boom. Each Monitor Extension supports 35 lbs.
- The LD+1 modality kit comes with one Monitor Extension (which includes one Standard knuckle) plus a Super knuckle to support your large display on the center boom. The Monitor Extension supports 35 lbs.
- The LD+2+1 modality kit comes with two Monitor Extensions (each with one Standard knuckle) plus one Super knuckle to support your large display on the center boom. The center boom comes with a Standard knuckle which supports one of the standard diagnostic displays. Each Monitor Extension supports 35 lbs.

PRODUCT	Weight Capacity	Weight	Part #	Price
2+1 Kit	29 lbs.	10 lbs.	RAD21BK	\$419.95
4+1 Kit	58 lbs.	12 lbs.	RAD41BK	\$1,099.80
LD+1 Kit	30 lbs.	16 lbs.	RADLD1BK	\$639.90
LD+2+1 Kit	50 lbs.	16 lbs.	RADLD21BK	\$959.85

## MONITOR EASY TRACK OPTIONS – FOR STEVE'S STATION FOR IMAGING

- Looking for monitor accessories for the STA-series and STD-series Steve's Station tables? Here they are! Those tables, sold 2011-2014, featured a single-boom Monitor Easy Track assembly, compared to a dual-boom assembly on Steve's Station Essential and STB-series Steve's Station tables.
- Tables come with a 33"-wide central boom assembly. Add knuckles to install your displays and Monitor Boom Extensions to expand the width of the boom. Knuckles and Extensions are sold separately.

### Monitor Easy Track Boom Extensions

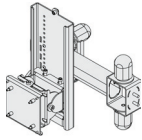

MONITOR EXTENSION, SMALL

- Add Monitor Easy Track Boom Extensions to your table to hold more displays! Advanced and Deluxe tables come with a 33" long center boom. Extend that with Monitor Boom Extensions. Extensions attach to the end of the boom with 1.25"-long articulating bracket. Available in three widths: small (10.5" long, holds 35 lbs.), medium (15", holds 35 lbs.), and large (22", holds 25 lbs.).
- On Deluxe tables, measure the available width between the panels before selecting a Monitor Boom Extension.
- Comes with one Standard knuckle. Additional knuckles sold separately.

PRODUCT	Width	Height	Weight	Part #	Price
Monitor Extension, Small	10.5"	2.5"	13 lbs.	STME1BK	\$299.95
Monitor Extension, Medium	15"	2.5"	14 lbs.	STME2BK	\$319.95
Monitor Extension, Large	22"	2.5"	15 lbs.	STME3BK	\$329.95

### Monitor Easy Track Knuckles

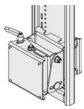

MONITOR KNUCKLE

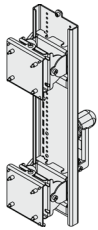

MONITOR VERTICAL EXTENSION

- Choose from the Standard and Super Knuckle based on the weight of your display. Knuckles slide into a monitor track and rest on the monitor block which adjusts in height in 1" increments. The monitor track attaches to the boom or boom extension at any position horizontally. Reposition the track's lateral position easily by loosening a single knob.
- Each knuckle provides tilt and swivel adjustment.
- The Standard knuckle (STKNABK) supports displays up to 35 lbs. and comes with VESA 75mm and 100mm pattern. The knuckle slides into the monitor track with 7" height adjustment in 1" increments. Fine-tune the monitors' height and yaw using a pair of screws.
- For larger displays weighing 25-60 lbs, choose the Super knuckle (STKNBBK). This knuckle also slides into the monitor track with 5" height adjustment in 1" increments and fine-tune adjustment for height and yaw. Comes with a 9" tray to hold transformer brick.
- Need to stack two standard displays for your RIS, dictation, or other system? Add the Monitor Easy Track Vertical Extension (STMVBK). It installs on the center boom or a monitor extension and comes with two standard knuckles. Supports two displays, one above the other, up to 35 lbs total and up to 17" apart, center to center.
- Each knuckle comes with a 15-ft DVI-D cable to route from your display, through the table's cable management system, and to your computer. Routing your power and data cables through the table's cable management system ensures that your equipment stays connected through the table's entire range of motion, without disconnecting or damaging the ports. This cable is capable of transmitting resolution value of 2560x1600 at 60 hz.

PRODUCT	Weight Capacity	Width	Height	Weight	Part #	Price
Standard Monitor Easy Track Knuckle	35 lbs.	5.75"	12"	8 lbs.	STKNABK	\$209.95
Super Monitor Easy Track Knuckle	25-60 lbs.	5.75"	12"	9 lbs.	STKNBBK	\$319.95
Monitor Easy Track Vertical Extension	35 lbs.	5.75"	21.75"	15 lbs.	STMVBK	\$419.95

## COLOR CHOICES

Select your product colors from the following swatches. Replace "xx" with a 2-letter Laminate Code.



Metal Colors (GV)

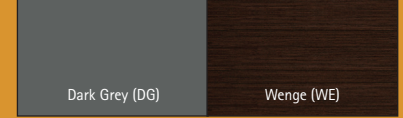

Laminate Colors (xx)

## POWER SOLUTIONS

Plug all of your electrical cords into a single strip to keep them organized and accessible. Choose the mounting option and features that are right for you.

### Power Bar

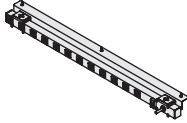

- Rated at 15 amps, 120 Volts. 2" spacing allows AC/DC adapters at each receptacle.
- Comes with 12' cord, on/off switch, on/off indicator light, and circuit breaker reset button.
- Slides into the cable enclosure.
- Covered by one-year warranty against manufacturing defects.

Silver Metallic (SM)

PRODUCT	Width	Depth	Height	Weight	Part #	Price
12 Receptacles	36"	2"	3"	8 lbs.	PBA12SM	\$199
16 Receptacles	48"	2"	3"	12 lbs.	PBA16SM	\$219

Power Bars do not provide surge protection. For Steves Station Essential only.

### Surge Protector

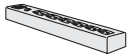

- These UL-listed surge suppressors are 12" long, have 6 outlets and are rated at 15 amps, 120 Volts. Come with on/off switch, on/off indicator light, and circuit breaker reset button.
- Covered by one-year warranty against manufacturing defects.
- Surge Protector - Comes in Black (BK) and attaches under a shelf with integrated mounting hardware or slips into the cable trough.

Black (BK)

PRODUCT	Cord Length	Depth	Weight	Part #	Price
Surge Protector - Standard	15'	2.5"	2 lbs.	520BK	\$84.95

For Steves Station Essential only.



205 Westwood Ave, Long Branch, NJ 07740  
 Phone: 866-94 BOARDS (26273) / (732)-222-1511  
 Fax: (732)-222-7088 | E-mail: sales@touchboards.com