

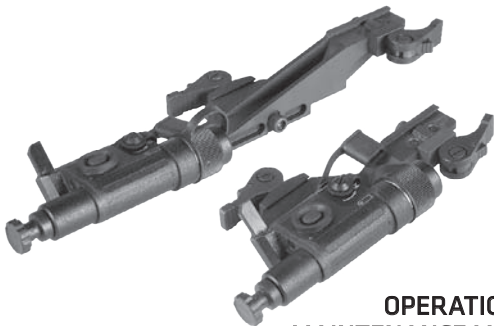

# AIM-PRO AIM-PRO-L

## Advanced Integrated Mounts



## OPERATION AND MAINTENANCE MANUAL

**Important Export Restrictions!** Commodities, products, technologies and services of this manual are controlled by the U.S. Department of State Office of Defense Trade Controls, in accordance with International Traffic in Arms (ITAR), Title 22, Code of Federal Regulations Part 120-130 and/or by the Export Administration Regulations (EAR) of U.S. Department of Commerce. At any time when a license or a written approval of the U.S. Government is applicable to it, it is illegal and strictly forbidden to export, intend to export, transfer in any other manner whatsoever, sell any hardware or technical data, provide any associated service to any non-U.S. resident, beyond or within the United States territory, until the valid license or written approval has been issued by the Departments of the U.S. Government having jurisdiction. Additionally U.S. law prohibits the sale, transfer, or export of items to certain restricted parties, destinations, and embargoed countries, as identified on lists maintained by the U.S. Department of State, the U.S. Department of Commerce, and the U.S. Department of Treasury. It is the responsibility of the Customer to be aware of these lists. The sale, transfer, transportation, or shipment outside of the U.S. of any product prohibited or restricted for export without complying with U.S. export control laws and regulations, including proper export licensing, documentation or authorization, is unlawful and may result in civil and/or criminal penalties and/ or constitute a federal crime. Diversion contrary to U.S. law is strictly prohibited.

## SAFETY SUMMARY

**Before operating this device, carefully study this Operation and Maintenance Manual.**

The Armasight AIM-PRO (Advanced Integrated Mount) is a precision electro-optical instrument and requires careful handling. To avoid physical danger or equipment damage when using the AIM-PRO, always follow all WARNINGS, CAUTIONS and NOTES.

Definitions of alerts that appear throughout this Manual are below:

**WARNING** — Identifies a clear danger to the person operating the equipment.

**CAUTION** — Identifies risk of damage to the equipment.

**NOTE** — Serves to highlight essential procedures, conditions, statements, or convey important instructional data to the user.

We provide the information in this manual for introductory and instructional purposes only. The contents may undergo further changes with no commitment by Armasight to notify customers of those changes.

Armasight assumes no responsibility for any misprints or other mistakes that may be contained in this manual.

©2013 Armasight. All right reserved.

**WARNING:**

When installing the equipment on a weapon, verify that the weapon is CLEAR and that the SAFETY is ON before proceeding.

**CAUTION:**

Do not dismantle the equipment.

Keep the equipment clean.

Protect the AIM-PRO from moisture, sharp temperature changes, and electrical shocks.

To avoid damage to the intensifier tube, DO NOT turn on "DAY" mode if using the AIM-PRO in conjunction with a night vision monocular.

DO NOT over-adjust or force the controls.

DO NOT leave the equipment on when it is not being used.

Only adjust the AIM-PRO boresight with the LOCK screw loosened.

Lock the adjustment mechanism after the AIM-PRO boresight has been aligned.

Do not store the equipment without removing the battery first.

Thoroughly dry each component of the AIM-PRO before placing them into the storage carton.

**NOTES:**

Remember to zero your weapon prior to installing the AIM-PRO or adjusting the boresight.

The boresight adjustment screws are not permanently affixed to the device and can be completely unscrewed.

At operating temperatures below -20°C (-4°F), alkaline battery life will be significantly reduced. Under said conditions, the use of a lithium battery is recommended.

# LIST OF CONTENTS

TITLE	PAGE
<b>Safety Summary</b>	<b>2</b>
<b>List of Contents</b>	<b>4</b>
<b>List of Figures</b>	<b>6</b>
<b>List of Tables</b>	<b>7</b>
<b>How to Use This Manual</b>	<b>7</b>
<b>Chapter 1. INTRODUCTION</b>	<b>8</b>
1.1 General Information	8
1.1.1 Type of Manual	8
1.1.2 Model Number and Equipment Name	8
1.1.3 Purpose of Equipment	8
1.1.4 Reporting Equipment Improvement Recommendations	8
1.2 Warranty Information and Registration	9
1.2.1 Warranty Information	9
1.2.2 Limitation of Liability	10
1.2.3 Product Warranty Registration	10
1.2.4 Obtaining Warranty Service	11
1.3 List of Abbreviations	12
<b>Chapter 2. DESCRIPTION AND DATA</b>	<b>13</b>
2.1 System Description	13
2.2 AIM-PRO Specifications	15
2.3 Optional Equipment Specifications	16
2.4 Standard Components	17
2.5 Optional Equipment	18
2.6 Key Features	19
<b>Chapter 3. OPERATING INSTRUCTIONS</b>	<b>20</b>
3.1 Installation and Mounting	20
3.1.1 Battery Installation	20
3.1.2 Collimator Installation	21
3.1.3 Mounting the NVM to the AIM-PRO	21
3.1.4 Mounting an Optional 3X Magnifier to the AIM-PRO	24

3.1.5 Mounting an Optional Red Dot System to the AIM-PRO	25
3.1.6 Mounting the AIM-PRO to a Weapon	25
3.1.7 Clamping Device Adjustment	26
3.2 Controls	27
3.3 Operating Procedures	28
3.3.1 AIM-PRO Activation	28
3.3.2 AIM-PRO Boresight Adjustment	29
3.3.3 AIM-PRO Shut-Down	33
<b>Chapter 4. PREVENTIVE MAINTENANCE AND TROUBLESHOOTING</b>	<b>34</b>
4.1 Preventive Maintenance Checks and Services	34
4.2 Operator Troubleshooting	37
4.3 Maintenance	38
4.3.1 General	38
4.3.2 Cleaning Procedures	38
4.3.3 Boresight Testing	39
4.3.4 Battery Removal and Replacement	39
4.4 Return Instructions	39
<b>APPENDIX A. Product Warranty Registration Card</b>	<b>41</b>
<b>APPENDIX B. List of Spare Parts</b>	<b>42</b>

## LIST OF FIGURES

FIGURE	TITLE	PAGE
2-1	AIM-PRO Advanced Integrated Mount Appearance	13
2-2	AIM-PRO-L Advanced Integrated Mount Appearance	14
2-3	AIM-PRO Advanced Integrated Mount	14
2-4	AIM-PRO Standard Components	17
2-5	Optional Equipment	18
3-1	Battery Installation	20
3-2	Collimator Installation	21
3-3	AIM-PRO Assembled with NYX-14 Night Vision Monocular	22
3-4	AIM-PRO-L Assembled with NYX-14 with 3X Lens	22
3-5	Mounting an Optional Bracket to the PVS-14/6015 NV Monocular	23
3-6	AIM-PRO Assembled with the PVS-14/6015 NV Monocular	23
3-7	AIM-PRO Assembled with an Optional 3X Magnifier	24
3-8	AIM-PRO Assembled with an Optional Red Dot System	25
3-9	Clamping Device on the Mount Underside	26
3-10	Clamping Device Adjustment	26
3-11	AIM-PRO Controls	27
3-12	Boresight Adjustment Screws	30
3-13	Adjustment Disk	31
B-1	AIM-PRO Spare Parts	43

## LIST OF TABLES

TABLE	TITLE	PAGE
2-1	AIM-PRO System Description	15
2-2	Mechanical Data	15
2-3	Collimator Optical Data	15
2-4	Collimator Electrical Data	16
2-5	Environmental Data	16
2-6	Optional Equipment Mechanical Data	16
2-7	3X Magnifier Optical Data	16
2-8	AIM-PRO Standard Components	17
2-9	AIM-PRO Optional Equipment	18
3-1	AIM-PRO Controls	28
4-1	Preventive Maintenance Checks and Services	35
4-2	Operator Troubleshooting	37
B-1	AIM-PRO Spare Parts List	43

## HOW TO USE THIS MANUAL

### USAGE

You must familiarize yourself with this entire manual before operating the equipment. Read the instructions on maintenance before performing any kind of maintenance checks or procedures. Follow all **WARNINGS**, **CAUTIONS**, and **NOTES**.

### MANUAL OVERVIEW

This Manual contains sections on operating and maintaining the AIM-PRO and AIM-PRO-L Advanced Integrated Mounts.

The AIM-PRO and AIM-PRO-L have a similar design and are described and referred to in this manual as pertaining to the AIM-PRO. Any differences in the AIM-PRO-L are considered separately.

Throughout this Manual, the AIM-PRO Advanced Integrated Mount will be referred to as the AIM-PRO, the device, or the equipment.

The Product Warranty Registration Card is in Appendix A.

A list of Spare Parts appears in Appendix B.

# INTRODUCTION

## 1.1 GENERAL INFORMATION

### 1.1.1 TYPE OF MANUAL

Operation and Maintenance (including a List of Spare Parts).

### 1.1.2 MODEL NUMBER AND EQUIPMENT NAME

Armasight AIM-PRO Advanced Integrated Mount.

Armasight AIM-PRO-L Advanced Integrated Mount.

### 1.1.3 PURPOSE OF EQUIPMENT

The AIM-PRO is a night vision accessory intended for use in conjunction with many of the Armasight Night Vision Monoculars, such as the NYX-14, Spark, Sirius, and the NVS-14 analog or PVS-14/6015. The AIM-PRO allows the user to mount night vision monoculars onto a variety of weapons so they may act as weapon sights. Adjustable brightness for the Manual Aiming pattern ensures accurate AIM-PRO, even when the environment has poor visibility and changing light conditions. The device functions well during nighttime conditions (moonlight, starlight, etc.), as well as in daylight (when used with the AIM-PRO optional 3X Magnifier or Red Dot System).

Manufactured from aluminum alloys, the AIM-PRO mount system is light but durable, robust, and designed to fit any Picatinny MIL STD 1913 or Weaver weapon rail. Lever-cam clamping devices ensure quick, easy, and reliable mounting and disassembly.

### 1.1.4 REPORTING EQUIPMENT IMPROVEMENT RECOMMENDATIONS

User recommendations for improvements are encouraged. Send an email to [info@armasight.com](mailto:info@armasight.com), or mail your comments to:

Armasight Inc.

815 Dubuque Avenue, South San Francisco, CA 94080, USA



## 1.2 WARRANTY INFORMATION AND REGISTRATION

### 1.2.1 WARRANTY INFORMATION

This product is guaranteed to be free from manufacturing defects in material and workmanship under normal use for a period of two (2) years from the date of purchase. This Warranty does not cover the battery, nor does it protect against damage due to loss, misuse or mishandling.

In the event a defect that is covered by the foregoing Warranty occurs during the applicable period stated above, Armasight, at its option, will either repair or replace the product, and such action on the part of Armasight shall be the full extent of Armasight's liability, and the Customer's sole and exclusive remedy. This Warranty does not cover a product (a) used in other than its normal and customary manner; (b) subjected to misuse; (c) subjected to alterations, modifications or repairs by the Customer of by any party other than Armasight without prior written consent of Armasight; (d) special order or "close-out" merchandise or merchandise sold "as-is" by either Armasight or the Armasight dealer; or (e) merchandise that has been discontinued by the manufacturer and either parts or replacement units are not available due to reasons beyond the control of Armasight. Armasight shall not be responsible for any defects or damage that in Armasight's opinion is a result from the mishandling, abuse, misuse, improper storage or improper operation of the device, including use in conjunction with equipment that is electrically or mechanically incompatible with, or of inferior quality to, the product, as well as failure to maintain the environmental conditions specified by the manufacturer.

This Warranty is extended only to the original purchaser. Any breach of this Warranty shall be waived unless the Customer notifies Armasight at the address noted below within the applicable Warranty period.

The Customer understands and agrees that except for the foregoing Warranty, no other warranties written or oral, statutory, expressed or implied, including any implied Warranty of merchantability or fitness for a particular purpose, shall apply to the product. All such implied warranties are hereby and expressly disclaimed.

### **1.2.2 LIMITATION OF LIABILITY**

Armasight will not be liable for any claims actions, suits, proceedings, costs, expenses, damages or liabilities arising out of the use of this product. Operation and use of the product are the sole responsibility of the Customer. Armasight's sole undertaking is limited to providing the products and services outlined herein in accordance with the terms and conditions of this Agreement. The provision of products sold and services performed by Armasight to the Customer shall not be interpreted, construed, or regarded, either expressly or implied, as being for the benefit of or creating any obligation toward any third party of legal entity outside Armasight and the Customer; Armasight's obligations under this Agreement extend solely to the Customer.

Armasight's liability hereunder for damages, regardless of the form or action, shall not exceed the fees or other charges paid to Armasight by the Customer or Customer's dealer. Armasight shall not, in any event, be liable for special, indirect, incidental, or consequential damages, including, but not limited to, lost income, lost revenue, or lost profit, whether such damages were foreseeable or not at the time of purchase, and whether or not such damages arise out of a breach of Warranty, a breach of agreement, negligence, strict liability or any other theory of liability.

### **1.2.3 PRODUCT WARRANTY REGISTRATION**

In order to validate the Warranty on your product, Armasight must receive a completed Product Warranty Registration Card for each unit or complete Warranty registration on our website at [www.armsight.com](http://www.armsight.com). Please complete the included form (Appendix A) and immediately mail it to our Service Center:

Armasight Inc.  
815 Dubuque Avenue  
South San Francisco, CA 94080  
USA

## **1.2.4 OBTAINING WARRANTY SERVICE**

To obtain Warranty service on your unit, the End-user must notify Armasight service department via e-mail ([service@armasight.com](mailto:service@armasight.com)) to receive a Return Merchandise Authorization number (RMA#).

When returning merchandise, please bring or send the product to our service center at the address noted above, postage paid, with a copy of your sales receipt. All merchandise must be fully insured with the correct postage; Armasight will not be responsible for improper postage, missing merchandise, or merchandise that is damaged during shipment.

When sending any product back, please clearly mark the RMA# on the outside of the shipping box. Please include a letter that indicates your RMA#, Name, Return Address, reason for service return, Contact information (such as a valid telephone number and/ or e-mail address), and proof of purchase, which will allow us to establish the valid start date of the Warranty. Product merchandise returns that do not have an RMA listed may be refused, or may be subject to a significant delay in processing.

The estimated Warranty service time is 10-20 business days from the time Armasight receives the returned product. The End-user/ Customer is responsible for paying postage on any items returned to Armasight for Warranty service. Armasight will cover return postage/ shipping to continental USA End-users/ Customers after Warranty repair only if the product is covered by aforementioned Warranty. Armasight will return product after Warranty service by domestic ground service and/or domestic mail. Any other requested, required or international shipping methods will require that the postage/ shipping fee be the responsibility of the End-user/ Customer.

## 1.3 LIST OF ABBREVIATIONS

C	Celsius (Centigrade)
CW	clockwise
CCW	counterclockwise
F	Fahrenheit
g	gram
H	Height
hr	hour
HUD	Head-Up Display
L	Length
LED	Light-Emitting Diode
m	meter
mils	milliradians
min	minimum
mm	millimeter
MOA	Minute Of Angle
NO.	Number
NVM	Night Vision Monocular
Para	Paragraph
PMCS	Preventive Maintenance Checks and Services
QTY	Quantity
RMA#	Return Merchandise Authorization number
SEQ	sequence
SR	Service Representative
V	Volt
W	Width

## DESCRIPTION AND DATA

### 2.1 SYSTEM DESCRIPTION

The AIM-PRO Advanced Integrated Mount is a night vision accessory that enables users to convert night vision monoculars into weapon sights.

The Armasight AIM-PRO-L allows the user to mount a 3X Night Vision Monocular directly onto their weapon to extend the shooting range.

The AIM-PRO consists of two primary parts: the quick-release mount system (hereafter referred to as “the mount”), and the optical-mechanical collimator device (“the collimator”).

The fully-assembled AIM-PRO is shown in Figure 2-1.

The fully-assembled AIM-PRO-L is shown in Figure 2-2.

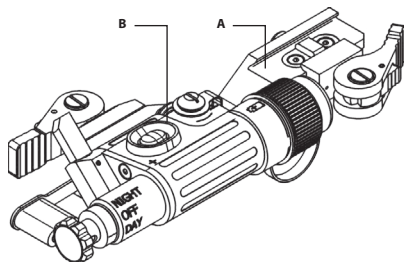
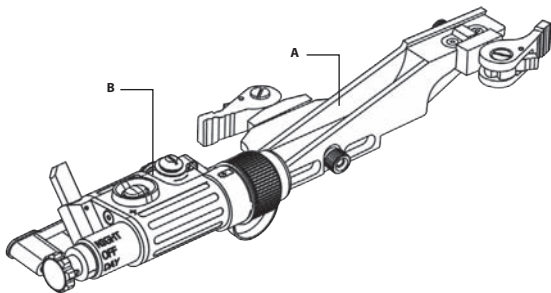

**FIGURE 2-1. AIM-PRO ADVANCED INTEGRATED MOUNT APPEARANCE**

The mount (A) has two lever-cam clamping devices. The first, which can be found on the bottom of the mount, fits any Picatinny MIL STD 1913 or Weaver rail. The second, which can be found on the top of the mount, fits any Armasight night vision monocular, as well as the optional AIM-PRO 3X Magnifier.

The collimator (B), which contains a light-emitting diode (LED) as an optical source, works as a pattern generator. The output HUD prism projects the

pattern — a red circle with an aiming dot in the center (hereafter referred to as the “aiming mark”) — directly into the objective lens of any night vision monocular that is installed on the AIM-PRO mount.



**FIGURE 2-2. AIM-PRO-L ADVANCED INTEGRATED MOUNT APPEARANCE**

The collimator includes a digital adjustment for changing the brightness of the aiming mark, as well as a manual boresight adjustment. The collimator is powered by a single AA or CR123A battery. The ITEM NO. column of Table 2-1 indicates the number used to identify the items in Figure 2-3.

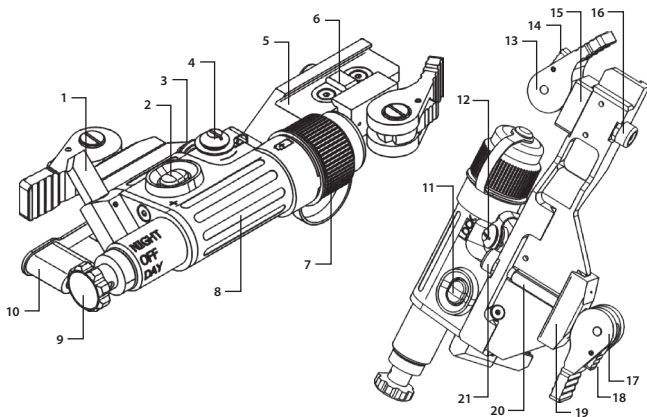

**FIGURE 2-3. AIM-PRO ADVANCED INTEGRATED MOUNT**

**TABLE 2-1. AIM-PRO SYSTEM DESCRIPTION**

ITEM NO.	DESCRIPTION	ITEM NO.	DESCRIPTION
1	Output Prism	11	Brightness Down Button (-)
2	Brightness Up Button (+)	12	Lock Screw (closed with a Cap)
3	Windage Adjustment Screw (closed with a Cap)	13	Cam Lever 1
4	Elevation Adjustment Screw (closed with a Cap)	14	Cam Lever 1 Holder
5	Mount Base	15	Clamp 1
6	Stop 1	16	Nut 1
7	Battery Cap w/Adapter	17	Cam Lever 2
8	Collimator Body	18	Cam Lever 2 Holder
9	Turn-Pull Switch	19	Clamp 2
10	Prism Cap	20	Stop 2
		21	Nut 2

## 2.2 AIM-PRO SPECIFICATIONS

**TABLE 2-2. MECHANICAL DATA**

ITEM	AIM-PRO DATA	AIM-PRO-L DATA
Windage/Elevation Adjustment Range (min)	$\pm 1^{\circ}30'$	$\pm 1^{\circ}30'$
Weapon Mount Type	Picatinny MIL STD 1913 and Weaver Rails	Picatinny MIL STD 1913 and Weaver Rails
Overall Dimensions (mm)	169x87x42	270x85x49
Weight (g)	180	252

**TABLE 2-3. COLLIMATOR OPTICAL DATA**

ITEM	DATA
Exit Pupil Size (mmxmm, min)	2x6
Aiming Circle Size (MOA)	65
Aiming Dot Size (MOA)	3.2

**TABLE 2-4. COLLIMATOR ELECTRICAL DATA**

ITEM	DATA
Adjustment of Aiming Mark Brightness	Digital
Levels of Aiming Mark Brightness	11
Battery	Single AA(1.5V) or single CR123A (3.0 V)
Battery Life (hr) at 20 °C (68 °F):	
— in the Nighttime Mode	up to 7500 (at brightness level 11)
— in the Daylight Mode	up to 60 (at brightness level 11)

**TABLE 2-5. ENVIRONMENTAL DATA**

ITEM	DATA
Operating Temperature	-40 to +50°C (-40 to +122°F)
Storage Temperature	-50 to +50°C (-58 to +122°F)
MIL-STD-810	Complies

## 2.3 OPTIONAL EQUIPMENT SPECIFICATIONS

**TABLE 2-6. OPTIONAL EQUIPMENT MECHANICAL DATA**

ITEM	DATA	
	Overall Dimensions (mm)	Weight (g)
3X Magnifier for AIM #51 (ready-assembled with mount)	120×39×43	180
Red Dot System	135×39×57	146
AIM Bracket PVS-14 #62	46.5×40×44.5	14

**TABLE 2-7. 3X MAGNIFIER OPTICAL DATA**

ITEM	DATA
Magnification	3.5X
Field of View	8°
Entrance pupil diameter (mm)	26
Exit Pupil Diameter (mm)	7.4
Eye Relief (mm)	46
Diopter Adjustment Range (diopter)	±4



## 2.4 STANDARD COMPONENTS

All standard components of the AIM-PRO device are shown in Figure 2-4 and listed in Table 2-8.

The ITEM NO. column indicates the number used to identify all items in Figure 2-4.

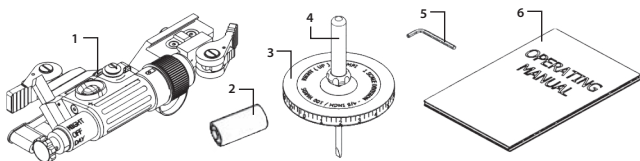

FIGURE 2-4. AIM-PRO STANDARD COMPONENTS

TABLE 2-8. AIM-PRO STANDARD COMPONENTS

ITEM NO.	DESCRIPTION	QTY
1	<b>Armasight AIM-PRO (or AIM-PRO-L) Advanced Integrated Mount</b> A weapon mount system equipped with a collimator aiming device.	1
2	<b>CR123A Lithium Battery</b> A single CR123A battery used to power the AIM-PRO.	1
3	<b>Adjustment Disk</b> Used to boresight adjustment the AIM-PRO.	1
4	<b>Screwdriver</b>	1
5	<b>1.5mm Allen Key</b>	1
6	<b>Operation and Maintenance Manual</b> Provides safety information, equipment description, mounting procedures, operating instructions, and preventive maintenance checks and services (including a List of Spare Parts).	1
—	<b>Carton</b> Packing box used for storage/ transportation of the AIM-PRO and its accessories.	1

## 2.5 OPTIONAL EQUIPMENT

Optional items are shown in Figure 2-5 and listed in Table 2-9.

The ITEM NO. column indicates the number used to identify items in Figure 2-5.

The PART NO. column indicates the primary number used by the manufacturer to identify an item.

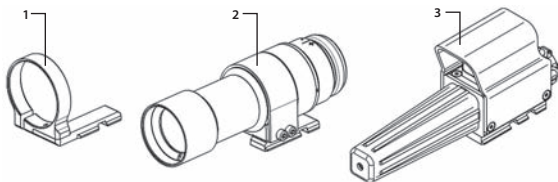

FIGURE 2-5. OPTIONAL EQUIPMENT

TABLE 2-9. AIM-PRO OPTIONAL EQUIPMENT

ITEM NO.	DESCRIPTION	PART NO.
1	<b>AIM Bracket PVS-14 #62</b> A dedicated mount used for installing the PVS-14/6015 Night Vision Monocular on the AIM-PRO.	ANKI000046
2	<b>3X Magnifier for AIM #52</b> An optical instrument used for observation and target range estimation in daylight conditions. Equipped with a dedicated mount to be installed on the AIM-PRO.	ANKI000048
3	<b>Red Dot System for AIM</b> A collimating sight used for “both-eyes open,” rapid-target acquisition in daylight conditions.	ANKI000033

## 2.6 KEY FEATURES

- Converts night vision monoculars into weapon sights
- The only solution that provides a 100% full-field of view for the attached night vision monocular
- No obstructing optics or parts in the field of view
- No need for an infrared laser
- Fast and easy target acquisition
- Digital adjustment of an aiming mark brightness
- Powered by a single AA or CR123 battery (adapter is included)
- Optional 3.5X daytime aiming solution
- Optional Red Dot daytime aiming solution
- Fits any Picatinny MIL STD 1913 or Weaver rail with an adjustable, locking, and quick-detach mount

# OPERATING INSTRUCTIONS

## 3.1 INSTALLATION AND MOUNTING

### 3.1.1 BATTERY INSTALLATION

**NOTE:**

At operating temperatures below  $-20^{\circ}\text{C}$  ( $-4^{\circ}\text{F}$ ), alkaline battery life will be significantly reduced. Under said conditions, the use of a lithium battery is recommended.

Install the battery as follows (refer to Figure 3-1):

1. Unscrew the battery cap (A) and check the position of the adapter (B). See Figure 3-1 for the correct positioning of the threaded adapter, which changes depending on the battery being installed.
2. If necessary, change the adapter position in the cap.
3. Install the battery (C) into the battery compartment (E). Align with the battery symbols (D).
4. Replace the battery cap (A).

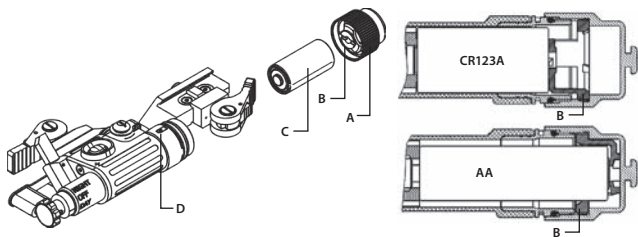

FIGURE 3-1. BATTERY INSTALLATION

### 3.1.2 COLLIMATOR INSTALLATION

The AIM-PRO collimator is fixed with two screws in the matching groove (Figure 3-2, A). It can be mounted in one of two possible positions, using the appropriate threaded openings found in the mount base and collimator body (see below).

Position 1: Shown in Figure 3-2; to be used with the NYX-14 or PVS-14 analog night vision monoculars (NVM).

Position 2: Shown displaced by 8mm (dash line); to be used with the Armasight Spark or Sirius devices.

See Figure 3-3 (Part 3.1.3) for the correct position of the AIM-PRO collimator when used with the NYX-14 Night Vision Monocular.

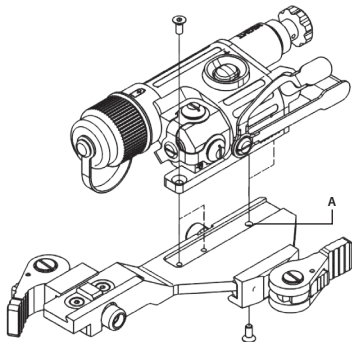

**FIGURE 3-2. COLLIMATOR INSTALLATION**

Reposition the collimator as follows:

1. Using a 1.5mm Allen key, unscrew both fixing screws.
2. Shift the collimator to the required position within the matching groove (A).
3. After applying a small amount of thread lock to the threads, install and tighten the screws.

### 3.1.3 MOUNTING THE NVM TO THE AIM-PRO

#### **A. Mounting the Armasight NYX-14/ Spark/ Sirius Night Vision Monocular to the AIM-PRO**

Figure 3-3 shows the fully-assembled AIM-PRO connected to the NYX-14 Night Vision Monocular.

Figure 3-4 shows the fully-assembled AIM-PRO-L connected to the NYX-14 Night Vision Monocular with a 3X afocal lens.

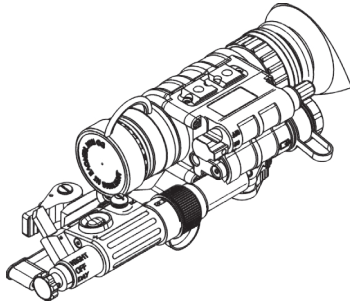

**FIGURE 3-3. AIM-PRO ASSEMBLED WITH NYX-14 NIGHT VISION MONOCULAR**

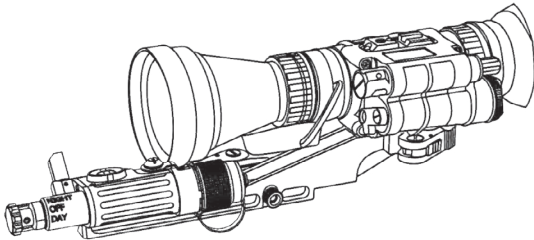

**FIGURE 3-4. AIM-PRO-L ASSEMBLED WITH NYX-14 WITH 3X LENS**

For instructions on positioning the AIM-PRO collimator, see Part 3.1.2 (Collimator Installation).

Mount the NVM to the AIM-PRO as follows:

1. If necessary, reposition the collimator on the AIM-PRO mount as per Part 3.1.2.
2. To unlock the clamping device (located on top of the mount), see Figure 3-4. While pushing the lever holder (C) down, turn the lever (B) towards the arrow (forward).
3. Install the NVM on the mount so that the stop (A) is inserted into the transverse slot of the NVM rail.
4. Secure the NVM to the mount by turning the lever (B) to the locked position, as shown in Figure 3-4.

5. Verify that the clamping device is firmly secured to the NVM. If necessary, adjust the clamping device as per Part 3.1.6 (Clamping Device Adjustment).

### **B. Mounting PVS-14/6015 Night Vision Monocular to the AIM-PRO**

The NVM can be mounted to the AIM-PRO using an optional bracket. For instructions on how to position the AIM-PRO collimator, see Part 3.1.2 (Collimator Installation).

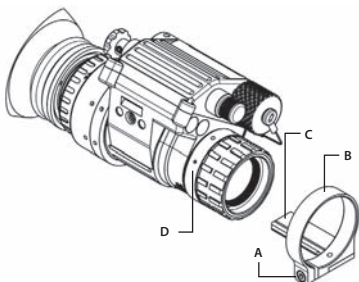

**FIGURE 3-5. MOUNTING AN OPTIONAL BRACKET TO THE PVS-14/6015 NV MONOCULAR**

Mount the NVM to the AIM-PRO bracket as follows (Refer to Figure 3-5):

1. Loosen the bracket clamp screw (A).
2. Place the bracket clamp (B) onto the infinity focusing stop ring (D) of the NVM objective lens.
3. Secure the NVM to the bracket clamp (B) by tightening the screw (A).

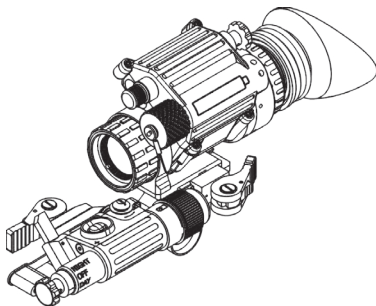

**FIGURE 3-6. AIM-PRO ASSEMBLED WITH THE PVS-14/6015 NV MONOCULAR**

4. Mount the NVM on the AIM-PRO with the bracket rail (C), as per Part 3.1.3-A.

Figure 3-6 shows the fully-assembled AIM-PRO connected to the PVS-14 analog Night Vision Monocular.

### 3.1.4 MOUNTING AN OPTIONAL 3X MAGNIFIER TO THE AIM-PRO

The optional 3X Magnifier (A, Figure 3-7) is delivered fully-assembled with a dedicated mount (B), to be installed on the AIM-PRO.

Install the 3X Magnifier on the AIM-PRO as follows:

1. Mount the 3X Magnifier (A) to the AIM-PRO using the rail (D). The mounting procedure is identical to that of mounting an NVM, as shown in Part 3.1.3.1. The position of the AIM-PRO collimator does not matter.
2. After mounting the AIM-PRO connected with the 3X Magnifier to a weapon, adjust the 3X Magnifier eyepiece using the diopter ring (C, Figure 3-7). Bring the 3X Magnifier image into sharp focus by rotating the eyepiece diopter ring. Directions of diopter adjustment are designated with (+/-) signs on the body of the 3X Magnifier. Adjustment range is covered in approximately 1 turn of the ring.

#### NOTE:

The 3X Magnifier reduces the exit pupil size of the AIM-PRO collimator by 3.5 times. For maximum visibility, accurate positioning of your eye in relation to the 3X Magnifier exit pupil is necessary. For eye relief, see Table 2-7.

3. If necessary, reposition the 3X Magnifier in the clamp (B); you must first release the fixing screws (E). Using a 2.5mm Allen key, tighten the screws.

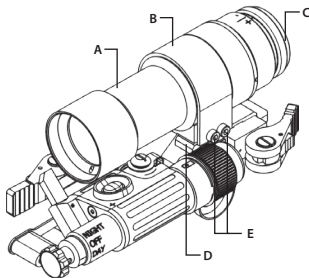

FIGURE 3-7. AIM-PRO ASSEMBLED WITH AN OPTIONAL 3X MAGNIFIER



### 3.1.5 MOUNTING AN OPTIONAL RED DOT SYSTEM TO THE AIM-PRO

Install the Red Dot System on the AIM-PRO as follows:

1. Mount the Red Dot System (A, Figure 3-8) to the AIM-PRO (B) using the rail (C). The mounting procedure is identical to that of mounting a 3X Magnifier, as shown in Part 3.1.4.

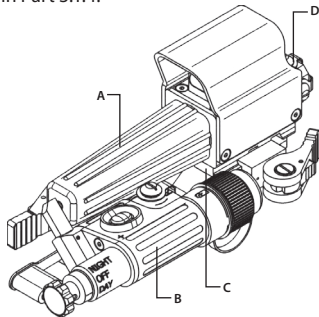

**FIGURE 3-8. AIM-PRO ASSEMBLED WITH AN OPTIONAL RED DOT SYSTEM**

2. After mounting the AIM-PRO connected with the Red Dot System to a weapon, adjust the Red Dot System boresight using the windage and elevation adjustment screws (D).

### 3.1.6 MOUNTING THE AIM-PRO TO A WEAPON

#### **NOTE:**

Remember to zero your weapon prior to installing the AIM-PRO or adjusting the boresight.

Mount the AIM-PRO to a weapon as follows (refer to Figure 3-9):

1. Unlock the clamping device beneath the mount by pushing the lever holder (A) down and turning the lever (B) towards the arrow (backwards).
2. Install the AIM-PRO on the weapon using a Picatinny/ Weaver rail. The stop (C) must be inserted into one of transverse slots of the weapon rail.
3. Secure the AIM-PRO to the weapon rail by turning the lever (B) into the locked position, as shown in Figure 3-9. The clamping device must firmly hold the weapon rail. If necessary, adjust the clamping device as seen in Part 3.1.6 (Clamping Device Adjustment).

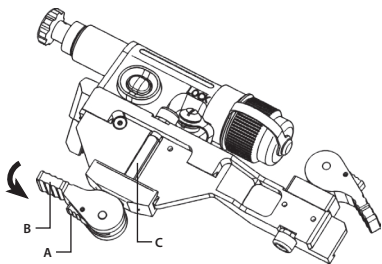

**FIGURE 3-9. CLAMPING DEVICE ON THE MOUNT UNDERSIDE**

### **3.1.7 CLAMPING DEVICE ADJUSTMENT**

Adjustment procedures are identical for both of the AIM-PRO clamping devices.

Adjust the holding power of the AIM-PRO clamping device as follows:

1. In order to detach the clamping device, remove the NVM/ 3X Magnifier from the AIM-PRO, or remove the AIM-PRO from the weapon.
2. With the clamping device (A) unlocked (as shown in Figure 3-10), push the cam (B) towards the arrow so that the nut (C) is released from the hole.
3. To tighten/ loosen the clamping device, push down on the cam (B) and turn the nut (C) CW or CCW, respectively, by one-two increments (see note below). When the cam (B) is released, the backward-moving springs will push the nut (C) back into the hole.

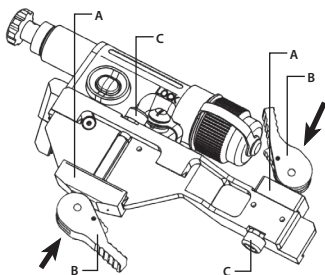

**FIGURE 3-10. CLAMPING DEVICE ADJUSTMENT**

**NOTE:**

The eight-sided nuts of the AIM-PRO clamping devices will only fit in their holes if turned in increments equal to  $360^{\circ}/8$ .

4. Verify that the clamping device is firmly secured to the weapon/ NVM rail.

## 3.2. CONTROLS

**CAUTION:**

DO NOT over-adjust or force the AIM-PRO controls past their stopping points.

**CAUTION:**

To avoid damage to the intensifier tube, DO NOT turn on "DAY" mode if using the AIM-PRO in conjunction with a night vision monocular.

The AIM-PRO controls described elsewhere in this manual (adjustment screws; clamping device levers and nuts) are omitted in this section. The AIM-PRO controls are shown in Figure 3-11, and are defined in Tables 3-1. The ITEM NO. columns of the tables indicate the number used to identify items in the figures.

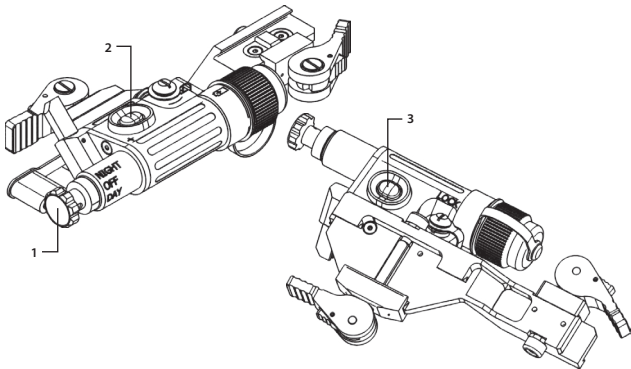

FIGURE 3-11. AIM-PRO CONTROLS

**TABLE 3-1. AIM-PRO CONTROLS**

ITEM NO.	CONTROL	FUNCTION
1	Turn-pull Switch	Switches the aiming mark on when turned to the NIGHT position, for operation in nighttime conditions in conjunction with a Night Vision Monocular. <hr/> Switches the aiming mark on when turned to the DAY position, for operation in daylight conditions in conjunction with the optional 3X Magnifier and Red Dot System. <b>NOTE:</b> In order to use DAY mode, you must pull the knob before turning. <hr/> Deactivates the AIM PRO when turned OFF.
2	Brightness Up Button (+)	Increases the brightness of the aiming mark.
3	Brightness Down Button (-)	Decreases the brightness of the aiming mark.

## 3.3 OPERATING PROCEDURES

### 3.3.1 OPERATING THE AIM-PRO

1. Switches the aiming mark on when the turn-pull switch is turned from "OFF" to "NIGHT.". These modes correspond to the minimum brightness of the aiming mark, for operation in nighttime conditions (in conjunction with Night Vision Monocular).
2. Switches the aiming mark on when the turn-pull switch is turned from OFF" to "DAY.". These modes correspond to the maximum brightness of the aiming mark, for operation in daylight conditions (with the optional 3X Magnifier and Red Dot System).
3. To select the optimal brightness level for the aiming mark, push the brightness adjustment buttons. Push the Brightness Up button (+) or the Brightness Down button (-) to increase or decrease the brightness of the aiming mark respectively.

There are 11 levels of aiming mark brightness for each mode. The initial level of the brightness is installed at 50% of the total brightness at each of the DAY and NIGHT modes. After changing the brightness, the new settings will be saved (separate for DAY and NIGHT modes). The settings will be saved even if the unit was turned off, as long as battery is installed.

**NOTE:**

When the battery is removed, the brightness will automatically return to the default level.

### 3.3.2 AIM-PRO BORESIGHT ADJUSTMENT

Figure 3-12 shows the boresight adjustment and lock screws.

**CAUTION:**

Adjust the AIM-PRO boresight with the LOCK screw (Figure 3-12, A) loosened.

Lock the adjustment mechanism after the AIM-PRO boresight is aligned.

**NOTE:**

To shift the aiming mark to the right, turn the screw (Figure 3-12, C) towards the arrow to the right (CCW). To shift it to the left, turn the screw (C) towards the arrow to the left (CW).

To shift the Aiming mark up, turn the screw (Figure 3-12, B) up towards the arrow (CCW). To shift the Aiming mark down, turn the screw (B) down towards the arrow (CW).

**NOTE:**

The boresight adjustment screws are not permanently affixed to the device and can be completely unscrewed. Windage and elevation adjustment ranges are covered in 3 turns of the screws.

The AIM-PRO boresight adjustment can be done during the day, either with the naked eye (Part 3.3.2.A), the Adjustment Disk (Part 3.3.2.B), an optional 3X Magnifier (Part 3.3.2.D), or with an optional Red Dot System (Part 3.3.2.E), as well as in nighttime conditions with an NVM (Part 3.3.2.C). The procedures are below.

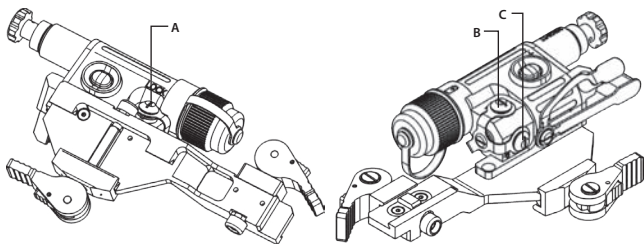

**FIGURE 3-12. BORESIGHT ADJUSTMENT SCREWS**

### **A. Boresight Adjustment in the Daytime with the Aiming Rest**

To visually adjust the AIM-PRO boresight in the daytime, do the following:

1. Mount the AIM-PRO to a weapon.
2. Locate a target at the fire adjustment range (100m).
3. Take AIM-PRO at the center of the target using the weapon's iron sight; secure the weapon in the aiming rest.
4. Unscrew the protective caps from the LOCK screw and the boresight adjustment screws.
5. Loosen the AIM-PRO LOCK screw with a screwdriver.
6. Turn on the AIM-PRO in DAY mode. Adjust the brightness level of the aiming mark.
7. With both eyes open, take aim at the target. Use a screwdriver to turn the windage and elevation adjustment screws until a red dot appears in the center of your field of view. Shift the dot to the center of the target. .
8. After you have completed the boresight adjustment procedure, tighten the LOCK screw and replace the protective caps.

### **B. Boresight Adjustment in the Daytime with the Adjustment Disk**

To adjust the AIM-PRO boresight in the daytime using the Adjustment Disk, do the following:

1. Mount the AIM-PRO to a weapon.
2. Locate a target at the fire adjustment range (100m).
3. Turn on the AIM-PRO in DAY mode. Adjust the brightness level of the aiming mark.
4. Take aim by centering the aiming mark of the device on the target, and fire a series of shots (3-4).

5. Find the center of impact and measure (in centimeters or inches) its vertical and horizontal deviations from the center of the target.
6. Work out the values of boresight correction required to compensate for the measured deviation of the center of impact from the center of the target. Boresight Increment is 2.2 cm for 100m fire range (4/5 of inch for 100 yards).
7. Unscrew the protective caps from the LOCK screw and boresight adjustment screws.
8. Loosen the AIM-PRO LOCK screw with a screwdriver.
9. Assemble the Adjustment Disk. Insert the screwdriver into the center of the disk (B) as shown in Figure 3-13. Secure the fixing screw to the bottom side of the disk.
10. Install the screwdriver of the Adjustment Disk into the adjustment screw of the AIM-PRO.

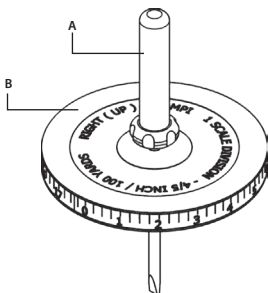

**FIGURE 3-13. ADJUSTMENT DISK**

11. Adjust the boresight by rotating the adjustment screw with the Adjustment Disk. One small division of scale of the Adjustment Disk corresponds to boresight increments of 2.2cm for 100m fire range (4/5 of inch for 100 yards).
12. After you have completed the boresight adjustment procedure, tighten the LOCK screw and replace the protective caps.
13. To check the boresight, fire a series of shots.

**C. Boresight Adjustment in the Nighttime with NVM**

To adjust the AIM-PRO boresight under nighttime conditions with NVM, do the following:

1. Mount the AIM-PRO to a weapon.

2. Locate a target at the fire adjustment range (100m).
3. Take aim at the center of the target using the weapon's iron sight; secure the weapon in the Aiming rest. Illuminate the target, if necessary.
4. Mount the NVM to the AIM-PRO.
5. Unscrew the protective caps from the LOCK screw and boresight adjustment screws.
6. Loosen the AIM-PRO LOCK screw with a screwdriver.
7. Turn on the NVM.
8. Turn on the AIM-PRO in NIGHT mode. Adjust the brightness level of the aiming mark.
9. Observing the target with the NVM, take aim at the target by turning the windage and elevation adjustment screws (use a screwdriver) until a red dot appears in the center of your field of view. Shift the dot to the center of the target.
10. After you have completed the boresight adjustment procedure, tighten the LOCK screw and replace the protective caps.

#### **D. Boresight Adjustment in the Daytime with an Optional 3X Magnifier**

To adjust the AIM-PRO boresight in the daytime using an optional 3X Magnifier, do the following:

1. Mount the AIM-PRO to the weapon.
2. Locate a target at the fire adjustment range (100m).
3. Take aim at the center of the target using the weapon's iron sight; secure the weapon in the aiming rest.
4. Mount the 3X Magnifier to the AIM-PRO.
5. Unscrew the protective caps from the LOCK screw and boresight adjustment screws.
6. Loosen the AIM-PRO LOCK screw with a screwdriver.
7. Turn on the AIM-PRO in DAY mode. Adjust the aiming mark brightness level.
8. Observing the target with the 3X Magnifier, take aim at the target by turning the windage and elevation adjustment screws (use a screwdriver) until a red dot appears in the center of your field of view. Shift the dot to the center of the target.
9. After you have completed the boresight adjustment procedure, tighten the LOCK screw and replace the protective caps.

#### **E. Boresight Adjustment in the Daytime with an Optional Red Dot System**

The boresight procedure is identical to that of boresight with a 3X Magnifier, as shown in Part 3.3.2.D.



If the AIM-PRO has been adjusted with an NVM or 3X Magnifier, you can save these settings and use the Red Dot System's adjustment screws.

To adjust the Red Dot System boresight in the daytime, do the following:

1. Mount the AIM-PRO to the weapon.
2. Locate a target at the fire adjustment range (100m).
3. Take aim at the center of the target using the weapon's iron sight; secure the weapon in the aiming rest.
4. Mount the Red Dot System to the AIM-PRO.
5. Unscrew the RDS's protective screws.
6. Turn on the AIM-PRO in DAY mode. Adjust the brightness level of the aiming mark.
7. Observing the target, take aim at the target by turning the windage and elevation adjustment screws of Red Dot System until a red dot appears in the center of your field of view. Shift the dot to the center of the target.
8. After you have completed the boresight adjustment procedure, replace the protective screws.

### **3.3.3 AIM-PRO SHUT-DOWN**

Shut down the AIM-PRO as follows:

1. Switch off the AIM-PRO.
2. Replace the cap on the collimator output prism.
3. Remove the AIM-PRO from the weapon.
4. Remove the NVM/ 3X Magnifier/ Red Dot System mounted on the AIM-PRO.
5. Remove the battery.

#### **CAUTION:**

Do not store the equipment with the battery installed.

6. Return the equipment and its accessories to the storage case.

# PREVENTIVE MAINTENANCE AND TROUBLESHOOTING

## 4.1 PREVENTIVE MAINTENANCE CHECKS AND SERVICES

Table 4-1: Preventive Maintenance Checks and Services (PMCS), has been provided so that you can keep your equipment in excellent operating condition.

Perform any functional tests in the order listed in Table 4-1.

Operating Procedures are detailed in Chapter 3.

### **Explanation of Table Entries:**

- **SEQ NO. column.** Sequence numbers are for reference, and appear in the order required for performing the checks and services.
- **LOCATION/ ITEM TO INSPECT/ CHECK/ SERVICE column.** Indicates the location and the item to be inspected, checked or serviced.
- **PROCEDURE column.** Details the checking/ servicing procedure.
- **NOT FULLY MISSION CAPABLE IF... column.** Indicates what faults will keep your equipment from being capable of performing its primary mission.

**TABLE 4-1. PREVENTIVE MAINTENANCE CHECKS AND SERVICES**

SEQ NO.	LOCATION/ ITEM TO INSPECT/CHECK/ SERVICE	PROCEDURE	NOT FULLY MISSION CAPABLE IF...
<b>BEFORE OPERATION CHECKS</b>			
1	Completeness	Open storage/ carrying carton and inventory items by comparing them with the data specified in this manual.	Items are missing.
2	Collimator Body	Inspect for dirt, cracks, damage, missing screws or missing prism cap. Scratches and gouges are admissible if operation is not affected. Clean as required.	Items are cracked or damaged. Some parts are missing.
3	Prism Cap	Inspect for dirt, dust, cuts and tears. Clean as required.	
4	Battery Compartment/ Cap/ Adapter	Inspect for corrosion, moisture, corroded or defective contacts, for damaged or missing o-ring. Clean as required.	Contacts damaged or corroded, o-ring damaged or missing.
5	Turn-Pull Switch	Check for operation (without the battery installed).	Switch is inoperative.
6	Output Prism	Inspect for dirt, scratches, chips, or cracks. Clean as required.	Scratches, chips or cracks are present.
7	Mount	Inspect for damage or corrosion, and for missing parts. Check for proper operation.	Damaged. Some parts missing. Clamping devices are inoperative.
8	Body of Optional 3X Magnifier	Inspect for dirt, corrosion, cracks, damage, or parts missing. Scratches and gouges are admissible if operation is not affected. Clean as required.	Cracked or damaged. Missing parts.
9	Lenses of Optional 3X Magnifier	Inspect for dirt, fingerprint residue, scratches, chips, or cracks. Clean as required.	Scratches or chips hinder vision. Cracks are present.

**TABLE 4-1. CONTINUED**

SEQ NO.	LOCATION/ ITEM TO INSPECT/CHECK/ SERVICE	PROCEDURE	NOT FULLY MISSION CAPABLE IF...
10	Diopter Ring of Optional 3X Magnifier	Rotate the diopter ring to make sure the eyepiece is not too tight or too loose. The range of the diopter is covered with approximately 1 turn of the ring.	Binding is not moving freely or is too loose, affecting adjustment of the diopter.
11	Body of Optional Red Dot System	Inspect for dirt, corrosion, cracks, damage, or missing parts. Scratches and gouges are admissible if operation is not affected. Clean as required.	Cracked or damaged. Missing parts.
12	Lenses of Optional Red Dot System	Inspect for dirt, fingerprint residue, scratches, chips, or cracks. Clean as required.	Scratches or chips hinder vision. Cracks are present.
13	Optional Bracket PVS-14	Inspect for dirt, corrosion, damage, and missing parts. Check for proper operation. Clean as required.	Equipment is damaged. Parts are missing.

#### OPERATIONAL CHECKS

**NOTE:**

Below the checks in daylight are described.

14	Switch	Install the battery. Turn the switch from "OFF" to "DAY" and change the brightness of aiming mark using the brightness adjustment buttons. Look for the red aiming mark to ensure the switch properly adjusts the brightness of the aiming mark.	No Aiming mark is visible. The brightness of the aiming mark doesn't change.
15	Boresight	Perform boresight testing as shown in Part 4.3.3.	Adjustment mechanism is inoperative.

#### POST-CHECK PROCEDURES

16		Turn the switch to "OFF". Remove the battery. Return the equipment to the storage/ carrying carton.	
----	--	---	--

## 4.2 OPERATOR TROUBLESHOOTING

The purpose of troubleshooting is to identify the most frequent equipment malfunctions, probable causes of those malfunctions and actions required to correct them.

Table 4-2 lists common malfunctions that may occur during the operation or maintenance of the AIM-PRO. Perform the tests, inspections and corrective actions in the order listed.

This table does not list all of the malfunctions that may occur with your device, nor does it list all of the tests and actions that may be necessary to correct them. If you experience an equipment malfunction that is not listed in this table, or find that the corrective action suggested does not alleviate the problem, please contact Armasight's Customer Service center.

**TABLE 4-2. OPERATOR TROUBLESHOOTING**

MALFUNCTION	PROBABLE CAUSE/ TEST/ INSPECTION	CORRECTIVE ACTION
AIM-PRO		
Collimator fails to activate (no Aiming mark).	Battery is dead, missing or improperly installed.	Replace the battery or install it correctly.
	Battery contact surfaces or contact springs are dirty or corroded.	Clean as per Part 4.3.2.
	Output prism is too dirty.	Clean output prism.
	LED is faulty.	Please contact Customer Support.
Turn-Pull Switch does not properly adjust the brightness of the aiming mark.	Switch is faulty.	Please contact Customer Support.
The brightness adjustment buttons do not properly adjust the brightness of the aiming mark.	Buttons are faulty.	Please contact Customer Support.
Adjustment screws do not adjust the position of the Aiming mark.	Adjustment mechanism is faulty.	Please contact Customer Support.

**TABLE 4-2. CONTINUED**

MALFUNCTION	PROBABLE CAUSE/ TEST/ INSPECTION	CORRECTIVE ACTION
3X Magnifier (optional)		
Diopter ring cannot be moved.	Diopter ring is bent or broken.	Please contact Customer Support.
Poor image quality.	Check for fogging or dirt on lens.	Clean lens as per Part 4.3.2. If image quality is still poor, please contact Customer Support.
	Damaged optical components.	Please contact Customer Support.

## 4.3 MAINTENANCE

### 4.3.1 GENERAL

The AIM-PRO operator maintenance consists of operational tests, inspections for unit serviceability, cleaning and mounting procedures, and corrective actions (troubleshooting and replacement of a limited number of parts). Maintenance instructions covered elsewhere in this manual (PMCS, troubleshooting, etc.) are **not** repeated in this section.

#### **CAUTION:**

The AIM-PRO is a precision electro-optical instrument and must be handled carefully at all times to prevent danger to the user or damage to the equipment.

### 4.3.2 CLEANING PROCEDURES

Clean the AIM-PRO and optional items as follows:

1. Gently brush off any dirt from the equipment using a clean, soft cloth.
2. Moisten the cloth with fresh water and gently wipe down the external surfaces (with the **exception** of glass surfaces).
3. Dry any wet surfaces (**except** for glass surfaces) with another dry, clean, soft cloth.
4. Using a lens brush, carefully remove all loose dirt from the glass surfaces (output prism, optional 3X Magnifier and Red Dot System lenses).

5. Slightly dampen a cotton swab with ethanol and gently, slowly wipe down the glass surfaces. Clean the glass surfaces using circular movements, starting from the center and moving out towards the edge, **without** touching the prism or lens holder. Change the cotton swab after each circular stroke. Repeat until the glass surfaces are clean.
6. Clean the battery contact surfaces and contact springs with a pencil eraser and/or alcohol-dampened cotton swabs.

#### **CAUTION:**

Thoroughly dry each item before placing them into the storage carton.

### **4.3.3 BORESIGHT TESTING**

Perform boresight testing:

- When the AIM-PRO is mounted to a weapon for the first time;
- After the first firing and after each 3-5 firings;
- After repair of the AIM-PRO/ weapon;
- As the need arises (in case of systematic inaccuracy or missing the target).

Test the AIM-PRO boresight as per Part 3.3.2.

### **4.3.4 BATTERY REMOVAL AND REPLACEMENT**

Refer to Part 3.1.1 for battery installation procedures.

## **4.4 RETURN INSTRUCTIONS**

For service, repair or replacement of your device, send an email to ***service@armasight.com***.

To assist the Service Representative (SR) in determining if the item is repairable, please provide the following information:

1. Serial Number of the defective item (this is engraved on the collimator body).
2. Thorough description of the malfunction, defect or damage.
3. An explanation of how the malfunction, defect or damage occurred, if known.

If the SR determines that the item is under warranty or should be returned for repair, a Return Material Authorization number (RMA#) will be provided. RMA can be obtained by sending an e-mail to [service@armasight.com](mailto:service@armasight.com); via phone, by calling Armasight Customer Service at (888)959-2259 Ext. 2; or via fax, by dialing (888)959-2260.

When returning the AIM-PRO for service or repair, the following procedures should be followed to prevent any additional damage:

1. Verify that the AIM-PRO is free of all contaminants, such as dirt or any other foreign material.
2. Remove the battery.
3. Place the cap over the output prism.
4. Place the AIM-PRO and accessories into the carton.

Place the AIM-PRO, as well as a copy of the test report or a detailed description of the failure, in a suitable packing/ shipping container. Mark the package with the RMA#. Ship the package using the fastest option available; the package should be traceable and all postage must be prepaid. Ship to:

Armasight Inc.  
815 Dubuque Avenue  
South San Francisco, CA 94080  
USA



# APPENDIX A

## PRODUCT WARRANTY REGISTRATION CARD

In order to validate the warranty on your product, Armasight must receive a completed Product Warranty Registration Card for each unit, or the user must complete a warranty registration form, which can be found on our website at [www.armsight.com](http://www.armsight.com). Please complete the included form and immediately mail it to our Service Center:

Armasight Inc.,  
815 Dubuque Avenue,  
South San Francisco, CA 94080,  
USA

### ARMASIGHT PRODUCT WARRANTY REGISTRATION CARD

#### PRODUCT INFORMATION

Product Name \_\_\_\_\_ Purchased From \_\_\_\_\_

Purchase Date \_\_\_\_\_ Product Serial # \_\_\_\_\_

#### CUSTOMER INFORMATION

Name \_\_\_\_\_

Address \_\_\_\_\_

City \_\_\_\_\_ Country \_\_\_\_\_ Zip \_\_\_\_\_

Day Phone # \_\_\_\_\_ Home Phone # \_\_\_\_\_

E-mail address \_\_\_\_\_

.....  
Customer Signature Required

# APPENDIX B

## LIST OF SPARE PARTS

The parts authorized by this list of spare parts are required for equipment maintenance. The list includes parts that must be removed in order to replace authorized parts.

The ITEM NO. column indicates the number used to identify items in Figure B-1.

The PART NO. column lists the primary numbers used by the manufacturer to identify an item. These numbers indicate the design and characteristics of the item in terms of its engineering drawings, specifications, standards, and inspection requirements.

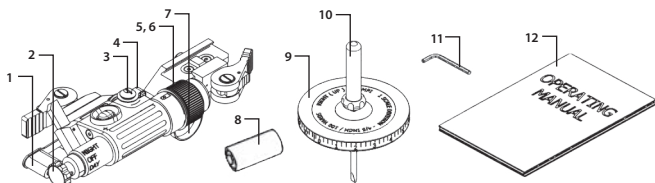

**FIGURE B-1. AIM-PRO SPARE PARTS**

**TABLE B-1. AIM-PRO SPARE PARTS LIST**

ITEM NO.	DESCRIPTION	PART NO.
1	Prism Cap	AIMPROPRC
2	Turn-Pull Switch	AIMPROTPS
3	Protective Cap	AIMPROPCP
4	Cap Retainer	AIMPROCPR
5	Battery Cap	AIMPROBC
6	Battery adapter (not shown)	AIMPROBA
7	Battery Cap Retainer	AIMPROBCR
8	CR123A Lithium Battery	ALT
9	Adjustment Disk	AIMPROAD
10	Screwdriver	AIMPROSD
11	1.5mm Allen Key	ALT
12	Operation and Maintenance Manual	AIMPROOMM



## Armasight Inc.

815 Dubuque Avenue  
South San Francisco, CA 94080

Phone: (888)959-2259

Fax: (888)959-2260

Intl Phone/Fax: (650)492-7755

[info@armasight.com](mailto:info@armasight.com)

[www.armasight.com](http://www.armasight.com)