

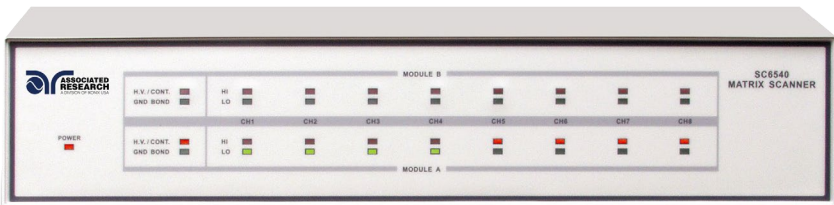

# Quick Start Guide

## SC6540

Model SC6540



### SAFETY CHECKLIST

- S**urvey the test station. Make sure it is safe & orderly.
- A**lways keep unqualified/unauthorized personnel away from the test area.
- F**amiliarize yourself with safety protocols in the event of a problem.
- E**xercise caution and never touch products or connections during a test.
- T**rain operators. Never touch clips directly and always connect the return lead first.
- Y**ou should always know when a test is being performed.



WARNING: THIS GUIDE WAS CREATED FOR OPERATORS HAVING SOME FAMILIARITY WITH ELECTRICAL SAFETY TESTING. AN ELECTRICAL SAFETY TESTER PRODUCES VOLTAGES AND CURRENTS THAT CAN CAUSE HARMFUL OR FATAL ELECTRIC SHOCK. TO PREVENT ACCIDENTAL INJURY OR DEATH, THESE SAFETY PROCEDURES MUST BE STRICTLY OBSERVED WHEN HANDLING AND USING A TEST INSTRUMENT. CONTACT US AT [INFO@ARISAFETY.COM](mailto:INFO@ARISAFETY.COM) FOR MORE INFO ON HOW TO GET TRAINED ON ELECTRICAL SAFETY TESTING.

# FRONT PANEL CONTROLS

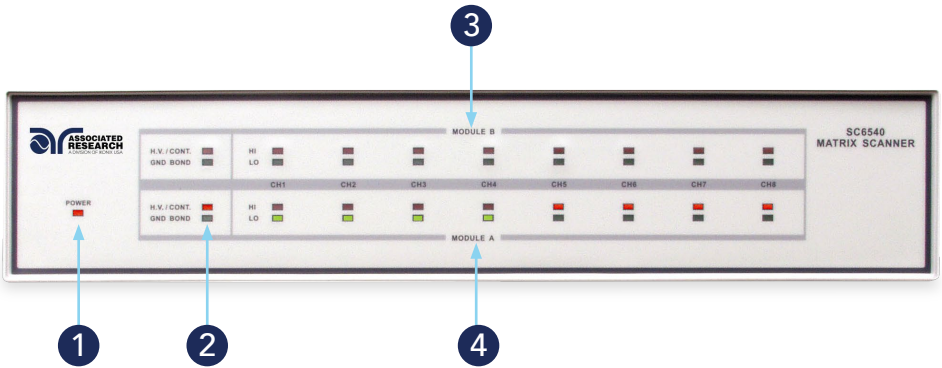

- 1 POWER INDICATOR:** Indicates the power has been turned ON. For a SC6540 Master, this lights up when the power switch on the rear panel of the unit is turned ON. For a SC6540 Slave, this lights up when the power switch on the host instrument is turned ON.
- 2 MODULE TYPE INDICATOR:** These LED's indicate the type of module that is installed for the corresponding module slot. If the red LED illuminates, it indicates that the installed module is a High Voltage/Continuity module. If the green LED illuminates, it indicates that the installed module is a Ground Bond module.
- 3 MODULE B CHANNEL STATUS INDICATORS:** These LED's indicate the status of each individual channel on Module B. If the red LED illuminates, it indicates a High Voltage/Continuity Current/Ground Bond channel. If the green LED illuminates, it indicates a Return channel.
- 4 MODULE A CHANNEL STATUS INDICATORS:** These LED's indicate the status of each individual channel on Module A. If the red LED illuminates, it indicates a High Voltage/Continuity Current/Ground Bond channel. If the green LED illuminates, it indicates a Return channel.

# BACK PANEL CONTROLS

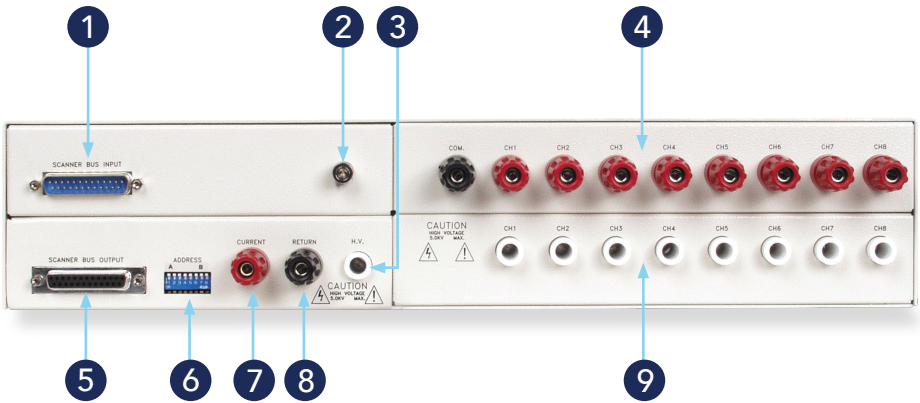

(Slave Scanner, HGS, Back Panel)

- 1 SCANNER BUS INPUT:** Interconnect port for the control cable between the SC6540 slave and an automated Associated Research electrical safety tester or SC6540 master Scanner.
- 2 SAFETY GROUND CONNECTOR:** Must be connected to a known good ground system to ensure operator safety.
- 3 HIGH VOLTAGE INPUT:** Connector for input of high voltage from the host instrument.
- 4 GROUND BOND OUTPUTS:** Output channels for application of high current for Ground Bond tests. These outputs are only available on SC6540 Scanners that are configured with a Ground Bond Module.
- 5 SCANNER BUS OUTPUT:** Interconnect port for the control cable to another SC6540 in a multiple SC6540 system.
- 6 ADDRESS SWITCHES:** 8-pin DIP switch used to address the modules in a SC6540 slave or used to configure the address of a SC6540 master.
- 7 CURRENT INPUT JACK:** Connector used to attach the high current input lead or Continuity Current input lead from the host instrument.
- 8 RETURN INPUT:** Connector for the return of the host instrument with the SC6540. This connection provides the Return Current path for the High Voltage, Ground Bond Current, and Continuity Current.
- 9 HIGH VOLTAGE OUTPUTS:** Eight individual output channels for High Voltage tests and Continuity tests. These outputs are only available on SC6540 Scanners that are configured with a High Voltage Module.

# BACK PANEL CONTROLS

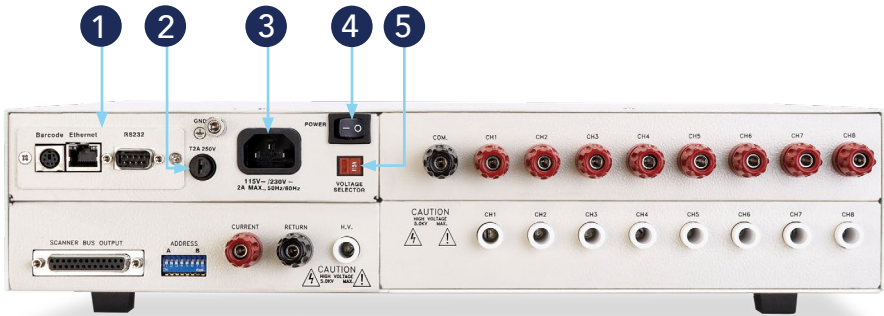

(Master Scanner, HGM, Back Panel)

- 1 BUS INTERFACE:** Standard connector for interconnection to the USB/RS-232 Bus interface. Optional IEEE-488 interface or Ethernet Interface may be substituted for the USB/RS-232.
- 2 FUSE RECEPTACLE:** To change the fuse, unplug the power (mains) cord and turn the fuse receptacle counter-clockwise. The fuse compartment will be exposed. Replace the fuse with one of the proper rating.
- 3 INPUT POWER RECEPTACLE:** Standard IEC 320 connector for a standard NEMA style line power (mains) cord.
- 4 POWER SWITCH:** Rocker style power switch with international ON (|) and OFF (0) markings.
- 5 INPUT VOLTAGE SWITCH:** Line voltage selection is set by the position of the switch. In the "left" position it is set for 110–120 volt operation, in the "right" position it is set for 220–240 volt operation.

# SCANNING CONFIGURATIONS

The SC6540 is available in two basic configurations according to how it sends and/or receives data: a master and a slave. A master Scanner can only be controlled remotely via a PC. A slave Scanner can be controlled locally by an Associated Research testing instrument or by a master Scanner.

## MASTER

A master Scanner communicates directly with a PC via a USB/RS-232 (standard), GPIB interface, or Ethernet. This model receives control information from a PC and can also deliver instructions to up to four additional slave Scanners. A master Scanner can be distinguished by its power module located on the upper left side of the rear panel.

### POWER MODULE



## SLAVE

A slave Scanner only receives data. The data that the slave receives can come from a master Scanner (remote control) or directly from an Associated Research instrument (local control). A slave Scanner can be distinguished by its input control bus located on the upper left side of the rear panel.

### INPUT CONTROL BUS

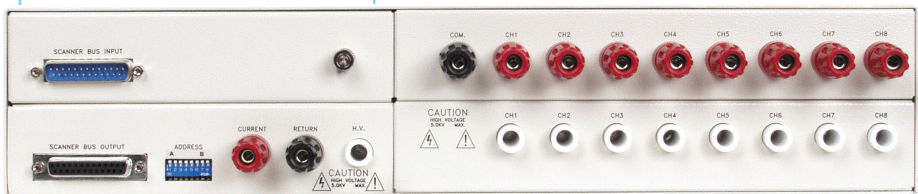

# BACK PANEL CONFIGURATIONS

The modular design allows for a variety of configurations. In addition to master or slave configurations, the scanners can also be set-up with the following configurations: 8 or 16 High Voltage testing channels, 8 High Voltage and Ground Bond testing channels, and 8 or 16 Ground Bond testing channels.



**Model SC6540 HNM**  
8 Channel High Voltage Scanner



**Model SC6540 HHM**  
16 Channel High Voltage Scanner



**Model SC6540 HGM**  
8 Channel High Current Scanner  
8 Channel High Voltage Scanner



**Model SC6540 GNM**  
8 Channel High Current Scanner



**Model SC6540 GGM**  
16 Channel High Current Scanner

\*Also available in slave configurations

The different configurations (shown right) are indicated by the following alpha designators.

- M** = Master Scanner
- H** = 8 High Voltage Channels
- HH** = 16 High Voltage Channels
- G** = 8 Ground Bond Channels
- GG** = 16 Ground Bond Channels
- N** = Empty Module
- S** = Slave

# CONNECTIONS



**WARNING:** UNDER CERTAIN CONDITIONS HIGH VOLTAGE CAN APPEAR ON THE CABINET OF THE SC6540. THE GROUND TERMINAL ON THE REAR PANEL OF THE SC6540 MUST BE CONNECTED TO A GOOD EARTH GROUND TO ENSURE OPERATOR SAFETY.



**CAUTION:** MULTIPLE HIGH VOLTAGE OR CONTINUITY CURRENT CHANNELS CAN BE SET TO ACTIVATE SIMULTANEOUSLY. HOWEVER, WHEN CONFIGURED THIS WAY THE SC6540 CANNOT PROVIDE AN INDICATION OF WHICH OUTPUT DETECTED FAILURE. THEREFORE, EACH ITEM OR TEST POINT WOULD HAVE TO BE RE-TESTED INDIVIDUALLY IF THE OPERATOR NEEDS TO DETERMINE THE EXACT POINT OF FAILURE.

## OPERATING THE SC6540 WITH HYPOTULTRA®

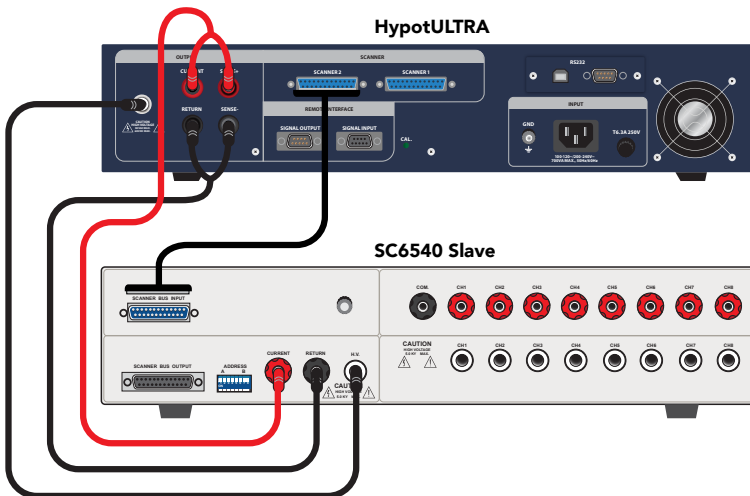
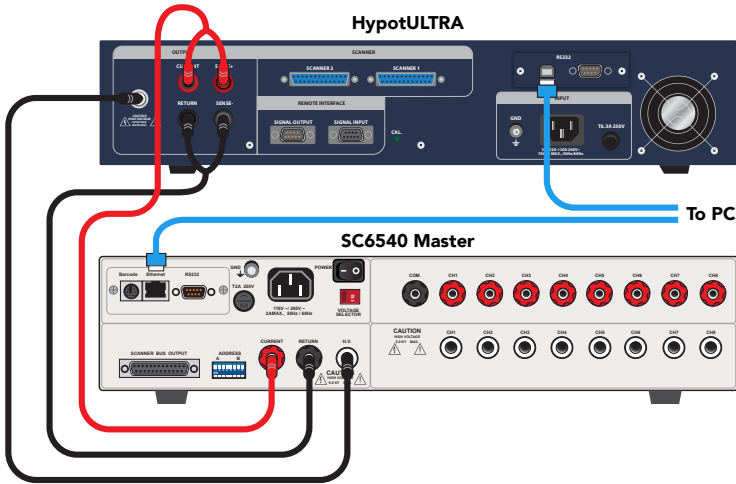

# CONNECTIONS

## OPERATING THE SC6540 WITH HYPOTULTRA (Continued)

### SETUP

The SC6540 Scanner channels can be set as High (H) for High Voltage or Continuity testing output, Low (L) for the Return connection, or Open (O) for OFF. Channel setup is done using the HypotULTRA menu or accompanying automation software. For information on SC6540 setup through Associated Research's Autoware® 3 Automation Software, consult the Autoware® 3 help file.

The following setup procedure will refer to setup through the HypotULTRA setup menu: from the Test Parameter Review screen (ACW, DCW, CONT, or IR) you can scroll to find the Scanner settings. Below is an example of the ACW Withstand Test Parameter Review screen.

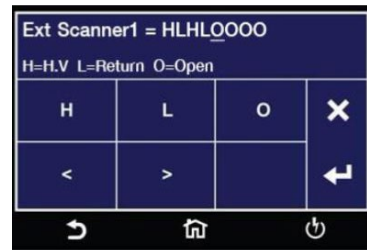
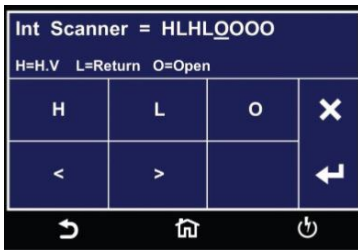

The above images show a HypotULTRA with 8 Internal Scanner channels and 8 external channels. The "Int Scanner" parameter in the menu pertains to an internal 8-channel Scanner and the "ExtScanner1" parameter pertains to an 8-channel high voltage SC6540 Scanner.

**Note:** Each Scanner port on the rear panel of the HypotULTRA can only control 8 channels of each type (HV or HC) at a time, which makes it possible to control a maximum total of 16 possible external Scanner channels. To control more than 16 external channels, automation software must be used along with a SC6540 Master and a PC.

To set the Scanner channels use the back (<) and forward (>) arrows and set the channels to High (H), Low (L) or Open (O). Use the enter key (↵) to save the values and move on to the next test parameter.

**H (High)** – High voltage output channel for a high voltage test or current output for a continuity test.

**L (Low)** – High voltage return channel for a high voltage test or a current return for a continuity test.

**O (Open)** – Channel is neither an output nor a return.



# CONNECTIONS

## OPERATING THE SC6540 WITH HYPOTULTRA (Continued)

### OPERATION

Once the SC6540 is incorporated into a test system, it will act as an extension of the HypotULTRA. The outputs will only activate while a test is being performed and will deactivate when the test is not running. When a failure is detected, the test will stop, the output will be deactivated and the HypotULTRA will give a visual and audible indication of failure. If steps were connected in sequence, the HypotULTRA will indicate a failure once it reaches the output that is connected to the defective device. The SC6540 will not continue to test the other outputs until the RESET button is pressed, the defective item is removed, and the TEST switch is pressed once again. The SC6540 will then begin to test from the first step in the program.



### Slave Scanner Power

Once the SC6540 slave is connected to the HypotULTRA, the “power on” LED will light up as soon as the power switch of the HypotULTRA is turned on.

### Master Scanner Power

The SC6540 master is powered on by flipping the switch on the rear panel of the unit to the ON position. The SC6540 Scanner channels will activate when the TEST signal is sent via a PC.

### LED Indicators

During a test, individual LED indicators for each output indicate whether the output is set as High, Low, or Open. If the channel is set as a High Voltage Output or Continuity Current Output, the red LED will light up. If the channel is set as Return, the green LED will light up. If the High Voltage channel is set to Open, no LED will light up.

# CONNECTIONS

## OPERATING THE SC6540 WITH OMNIA II® 8204

### GROUND BOND CONNECTIONS

The rear panel of the SC6540 can include up to 16 output terminals for Ground Bond testing if this configuration is selected at the time of purchase. \*We recommend using standard 12 gauge wire for operation at 30 amps, and 10 gauge wire for 40 amps.

The wires should be attached using the hook-style crimp lugs provided, to minimize connection resistance. The Kelvin connection of an Associated Research Ground Bond tester will end at the Ground Bond input terminals of the SC6540 Scanner. For this reason, the wire lengths going from the SC6540 High Current output and the High Current Return should be kept as short as possible to limit the effect of test lead resistance.

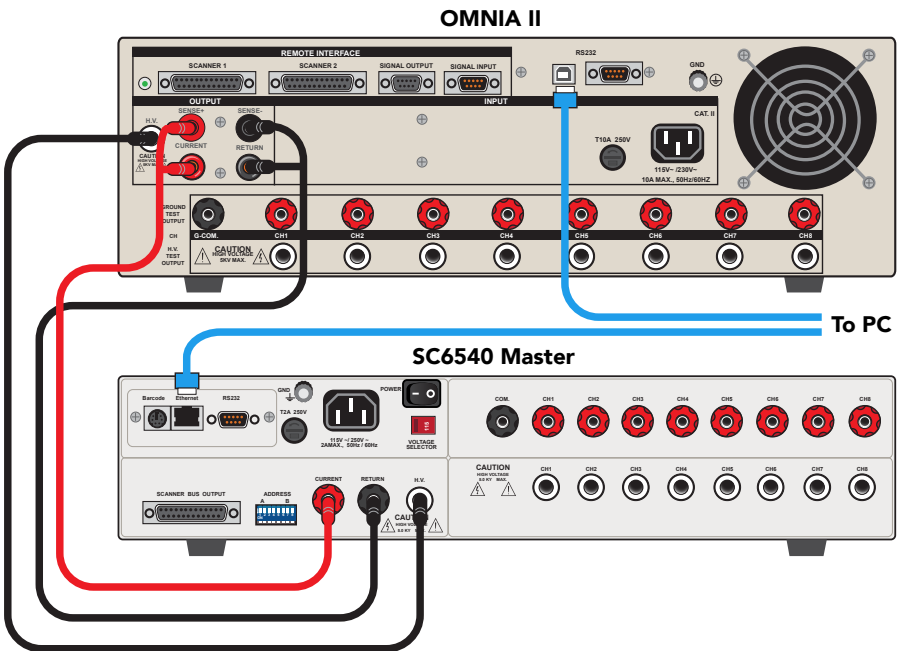

# CONNECTIONS

## OPERATING THE SC6540 WITH OMNIA II 8204 (Continued)

### GROUND BOND CONNECTIONS

#### OMNIA II

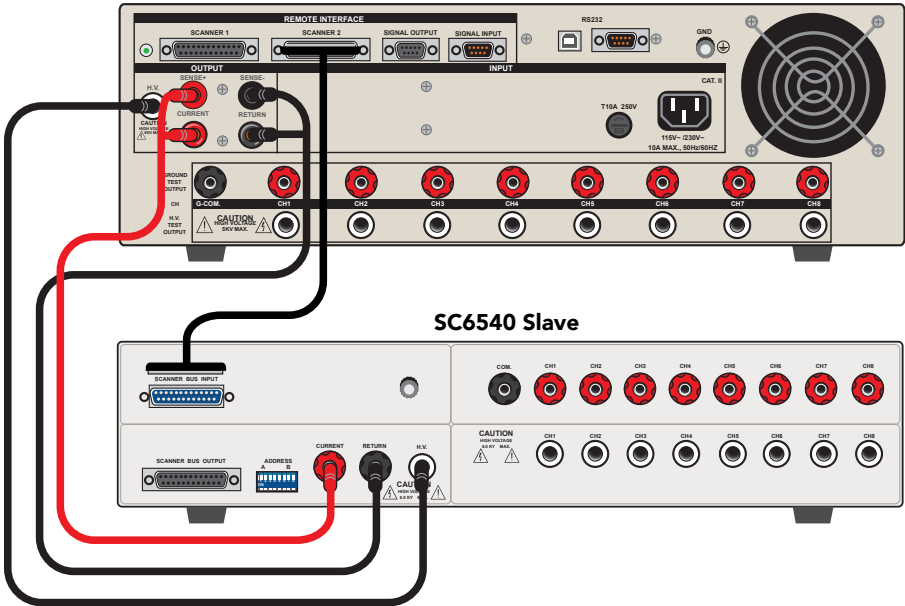

# CONNECTIONS

## OPERATING THE SC6540 WITH OMNIA II 8204 (Continued)

### SETUP

The SC6540 Scanner channels can be set as High (H) for High Voltage or Continuity testing output, Low (L) for the Return connection, or Open (O) for OFF. Channel setup is done using the OMNIA II menu or accompanying automation software. For information on the SC6540 setup through Associated Research's Autoware® Automation Software, consult the Autoware® 3 help file.

The following setup procedure will refer to setup through the OMNIA II setup menu: in the Setup Test Parameters screen (ACW, DCW, IR, Ground Bond or Continuity) you will find the Scanner settings. Below is an example of the ACW Withstand Test Setup Menu.

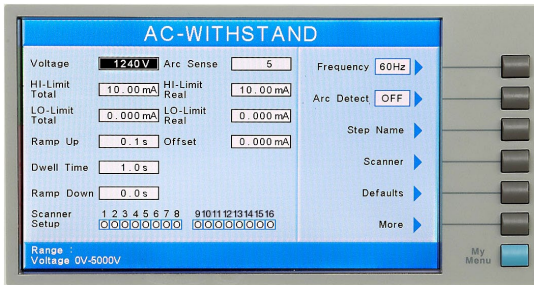

The above menu shows an OMNIA II connected to a 16-channel Scanner configuration. This configuration can be one external 16-channel Scanner (8 high voltage ports and 8 high current ports) or two external 8-channel Scanners. With two external 8-channel Scanners, one Scanner should be connected to the Scanner 1 connector on the rear panel of OMNIA II and the second Scanner should be connected to the Scanner 2 connector on the rear panel of OMNIA II.

**Note:** Each Scanner port on the rear panel of the OMNIA II can only control 8 channels of each type (HV or HC) at a time, which makes it possible to control a maximum total of 16 possible external Scanner channels. To control more than 16 external channels, automation software must be used along with a SC6540 Master and a PC.

Navigate the Test Setup screen using the arrow keys, located on the OMNIA II keypad, until you reach the Scanner Setup parameters. The Scanner channels can be set using the "Scanner Select" soft key located to the right of the LCD display. The Scanner channels can be set to one of three different states:

**H** (High) – High voltage output channel for a High Voltage test or current output for a Ground Bond or Continuity test.

**L** (Low) – High voltage return channel for a High Voltage test or a current return for a Ground Bond or Continuity test.

**O** (Open) – Channel is neither an output nor a return.

## OPERATING THE SC6540 WITH OMNIA II (Continued)

### OPERATION

Once the SC6540 is incorporated into a test system, it will act as an extension of the OMNIA II. The outputs will only activate while a test is being performed and will deactivate when the test is not running. When a failure is detected, the test will stop, the output will be deactivated and the OMNIA II will give a visual and audible indication of failure. If steps were connected in sequence, the OMNIA II will indicate a failure once it reaches the output that is connected to the defective device. The SC6540 will not continue to test the other outputs until the RESET button is pressed, the defective item is removed, and the TEST switch is pressed once again. The SC6540 will then begin to test from the first step in the program.



### Slave Scanner Power

Once the SC6540 slave is connected to the OMNIA II, the “power on” LED will light as soon as the power switch of the OMNIA II is turned on.

### Master Scanner Power

The SC6540 master is powered on by flipping the switch on the rear panel of the unit to the ON position.

### LED Indicators

The two leftmost LEDs for Module A and Module B indicate the type of module that has been installed. If the Red LED is illuminated there is a High Voltage module present. If the Green LED is illuminated there is a Ground Bond module present. During a test, individual LED indicators for each output indicate whether the output is set as High, Low, or Open. If the channel is set as a High Voltage Output, Ground Bond Output, or Continuity Current Output the red LED will light up. If the channel is set as Return, the green LED will light up. If the High Voltage channel is set to Open, no LED will light up.

# CONNECTIONS

## OPERATING THE SC6540 WITH LINECHEK 620L

### SETUP

This option allows the 620L to be connected to an Associated Research SC6540 Modular Scanning Matrix, model HN. With this option installed and a Scanner connected to the Scanner control bus on the rear of the instrument, the 620L and accompanying Scanner can be used for multi-point Line Leakage testing. The 620L will provide power and all necessary signals to the corresponding Scanner inputs.

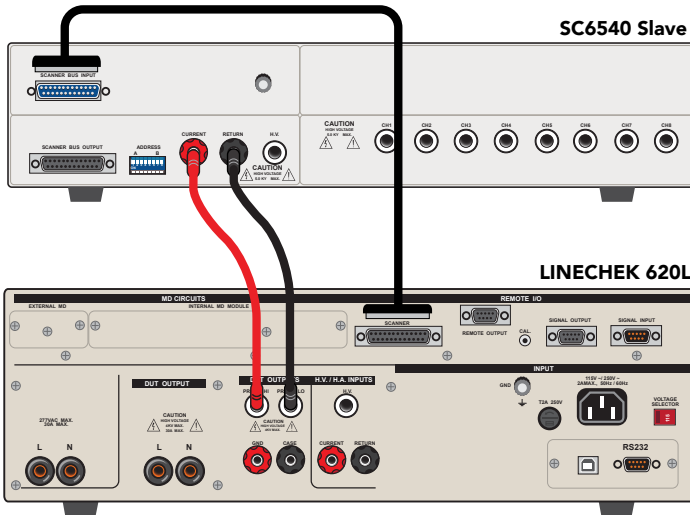

In order to connect the Scanner to the 620L, four connections must be made. Connect the Scanner control bus from the Scanner output on the rear panel of the 620L to the input on the rear panel of the Scanner using the included communications cable (38592). Connect the Probe-HI output on the panel of the instrument to the Current input on the panel of the Scanner. Connect the Probe-LO output on the panel of the instrument to the Return input on the panel of the Scanner. Finally, plug the DUT into the universal adaptor box.

# CONNECTIONS

## OPERATING THE SC6540 WITH LINECHEK 620L (Continued)

### OPERATION

Within the Line Leakage Edit screen on the 620L, the "Scanner Select" parameter (soft key) will automatically appear when the highlighted cursor moves to the Scanner Setup area using the Up and Down Arrow keys or Enter key. Press the "Scanner Select" soft key to toggle the Scanner channel between H (high), L (low), or O (off). Press the Left and Right Arrow keys to move the highlighted cursor to the corresponding Scanner channel. Setting a channel to H will connect the Probe-HI of the 620L to the corresponding Scanner channel. Setting a channel to L will connect the Probe-LO of the 620L to the corresponding Scanner channel.

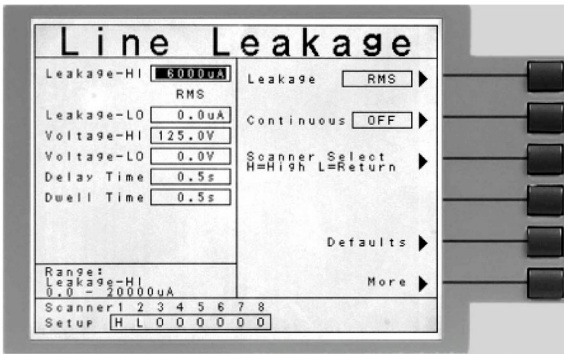

The operator may set the Scanner on a test-by-test basis. For example, for test step 01, the operator may set each of the Scanner channels in a particular configuration. For test step 02, the operator may wish to change the configuration of each Scanner channel.



Safety Is Our Only Focus®



For additional information about these and other key features of the SC6540, please consult the full Operation and Service Manual or call us toll-free 1-800-858-TEST (8378) or 1-847-367-4077  
© Associated Research • [arisafety.com](http://arisafety.com)

FOLLOW US!

