

SA46S
 SA46W
 SA46B
 SA46PB

Installation Instructions

SYSTEMA

Systema | Monitor Arm | 460mm

Component Checklist

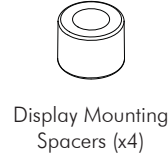
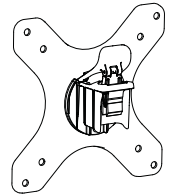
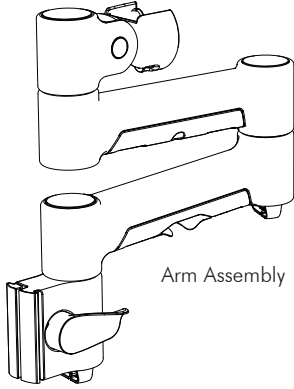

HARDWARE



Display Mounting Screws



IMPORTANT INFORMATION:

! IMPORTANT - Install Systema Monitor Arm as per installation instruction.

! This product supports a maximum load of 12kg (26.4lbs).

! The manufacturer accepts no responsibility for incorrect installation.

! The Systema Monitor Arm is compatible with Systema Posts: SP10, SP40, SP75 and with Wall Channels: SW6 & SW35.

Step 1. Check Components

Check what you have received against the component checklist and hardware above.

Step 2. Mount Arm Assembly

2.1 Remove Post Top Cap.

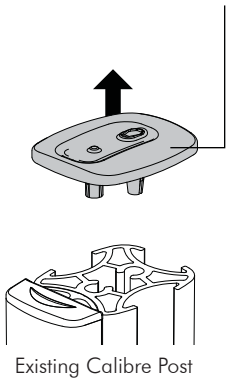

2.2 Insert Arm Assembly into Channel

Note: Squeeze and hold Clamp Head before inserting into the channel on Post Assembly or Wall Channel.

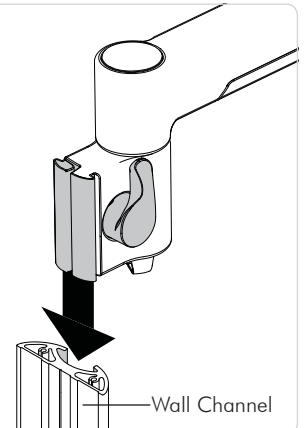
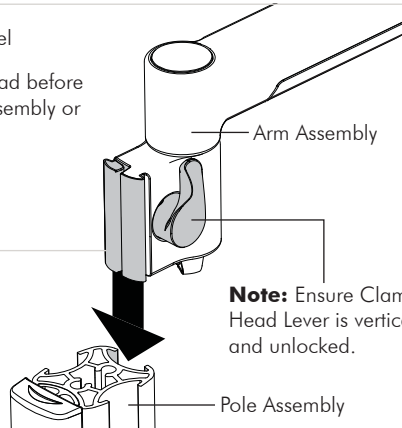
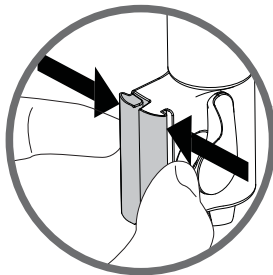

2.3 Move Channel Clamp to desired height and ensure arm is supported.

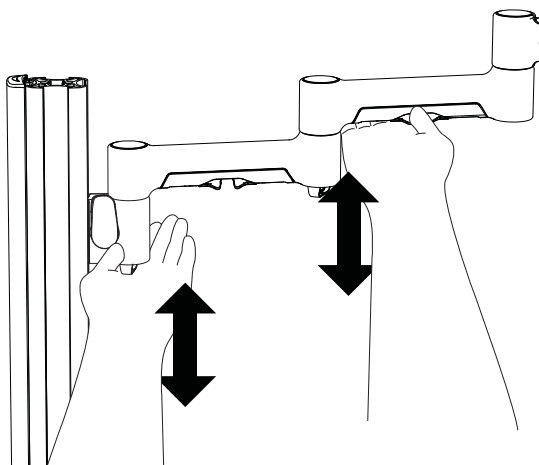

2.4 Lock Channel Clamp at preferred height.

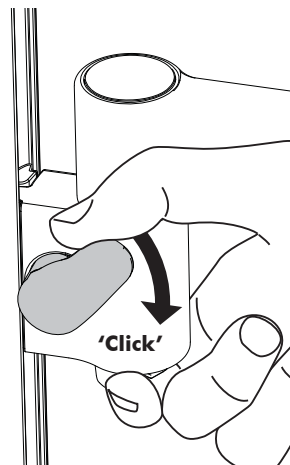

2.5 Insert Post Top Cap into Post Assembly.

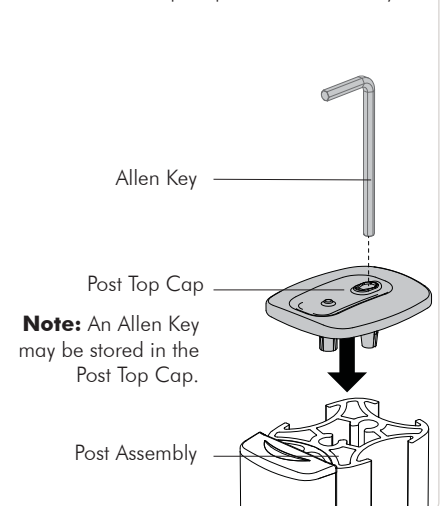

Step 3. Install VESA monitor head

3.1 Install VESA monitor head as shown.

VESA monitor head

Screen

M4x12/16/25mm Phillips Head Mounting Screws

Spacers (may be required for recessed and uneven surfaces)

100mm

75mm

100mm

75mm

Step 4. Mount Display

VESA monitor head

Arm Assembly

Note: Ensure the Lever is in the **up** position before installation onto the Arm Assembly.

4.1 Insert VESA monitor head into the receptacle in the Arm Assembly.

4.2 Ensure that the VESA monitor head sits flush within the Arm Assembly receptacle. There should be **no** gap.

Gap

No Gap

4.3 Once the VESA monitor head is sitting flush, push the lever down to secure it to the Arm Assembly.

Note: Support Screen when adjusting tilt.

4.4 OPTIONAL SECURITY SCREW
Ensure the Monitor is supported, then loosen the Monitor head screw with the 3mm Allen Key and tilt screen up before installing the M4 x 14mm Security Screw into the Security Screw hole.

Monitor head screw

Security Screw Hole

Loosen

3mm Allen Key

Tighten

M4 x 14mm Security Screw

Phillips Head Screwdriver

Step 5. Cable Management

5.1 Plug your cables into the monitor and follow this cable management system route.

Note: Ensure enough cable slack is given to allow for movement.

5.2 Push the cable up into the gap in the **upper** arm Cable Cover.

Cable Cover

Cable

Step 5. Cable Management (cont.)

5.3 Whilst maintaining pressure on the cable, slide the cable into the groove and follow it up.

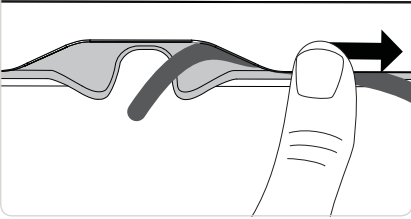

5.4 Whilst maintaining pressure on the cable, slide the cable into the groove and follow it down.

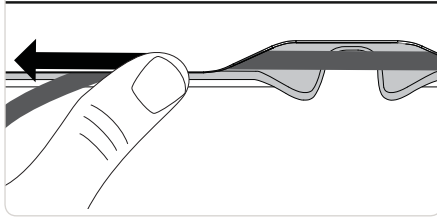

5.5 At the Elbow, pull one side of the clip down and push the cable through the gap.

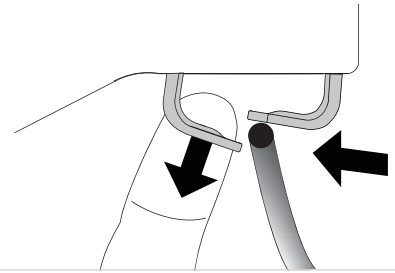

5.6 Push the cable up into the gap in the **lower** arm Cable Cover.

Cable Cover Cable

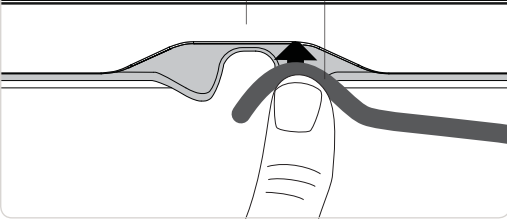

5.7 Whilst maintaining pressure on the cable, slide the cable into the groove and follow it up.

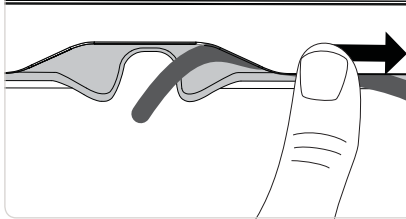

5.8 Whilst maintaining pressure on the cable, slide the cable into the groove and follow it down.

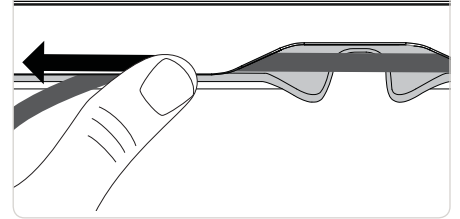

5.9 Under the Channel Clamp, pull one side of the clip down and push the cable through the gap.

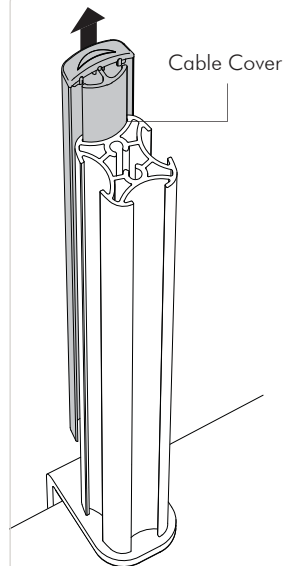
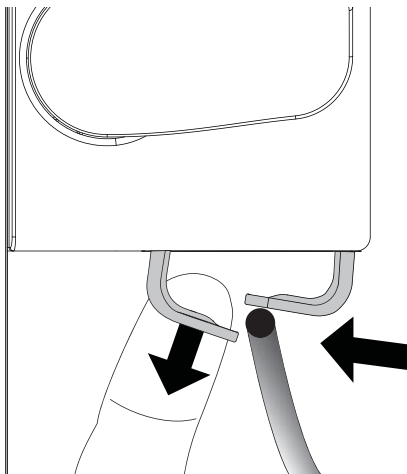

5.10 OPTIONAL

To reposition the Cable Cover, pull it straight up and out of the post and insert it into any of the available channels.

Note: The Cable Cover shown, only comes with SP40 or SP75 posts.

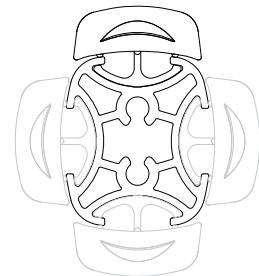

Optional Cable Cover Positions

Note: Choose 5.11 and/or 5.12 for your column cable management depending on your needs.

5.11 OPTIONAL

A. Loop cable and insert into Cable Cover.

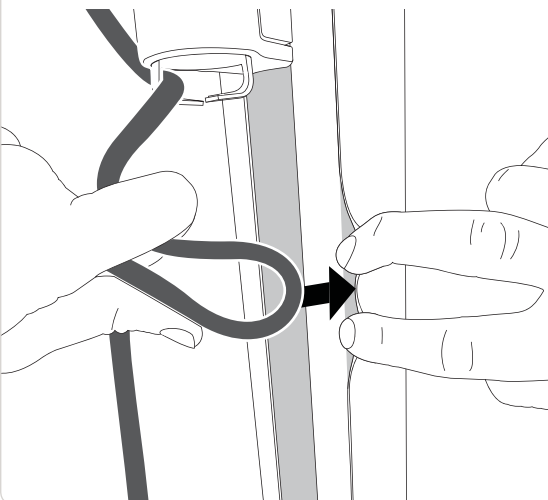

5.11 OPTIONAL

B. Push the Cable down into either side of the Cable Cover until it reaches the bottom.

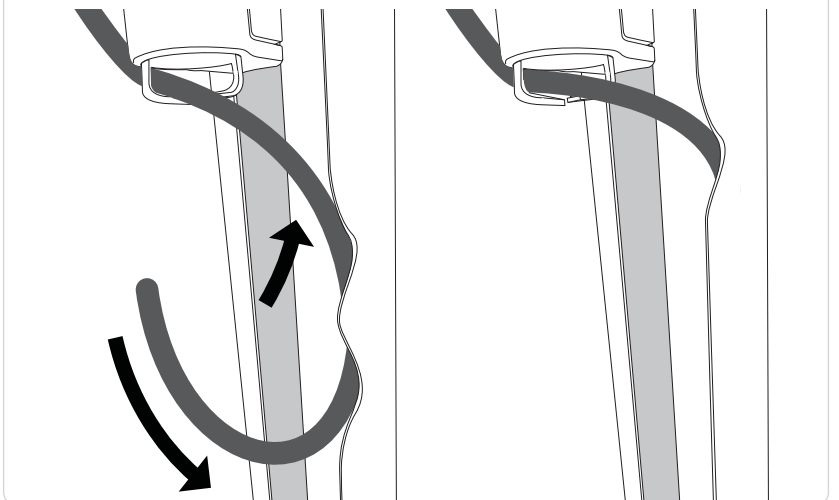

5.12 OPTIONAL (NOTE: Cable clips only come with SP40 and SP75 Posts or separately in SC4 accessory pack)

A. Push the cable down into the Cable Clip.

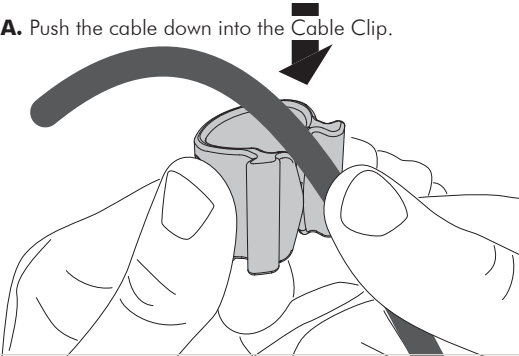

5.12 OPTIONAL

B. Insert one side of the Cable Clip into the Channel on the Post assembly or Wall channel, before pushing the other side in.

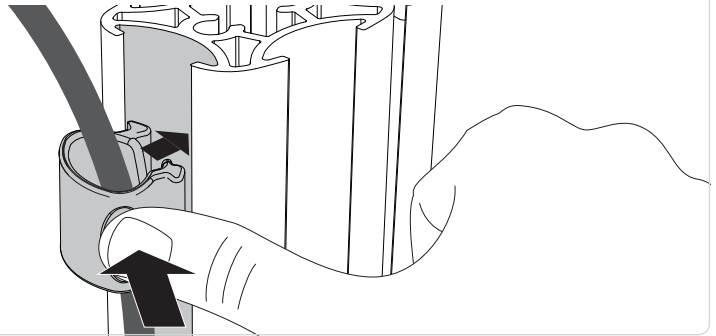

For a triple configuration Atdec recommends using:

Post Cable Cover

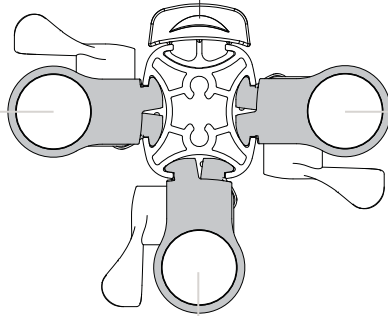
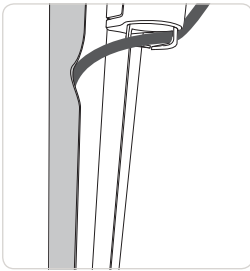

Post Cable Cover

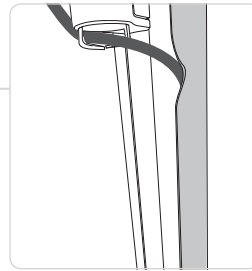

Post Cable Clip

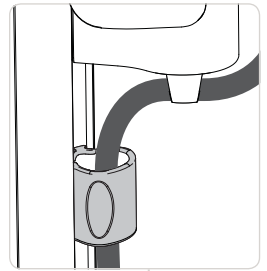

Step 6. Adjusting the Display Bracket

Portrait/Landscape

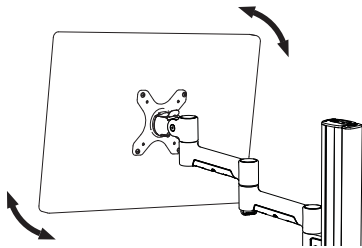

No Allen Key necessary

Tilt (Screen angle up/down)

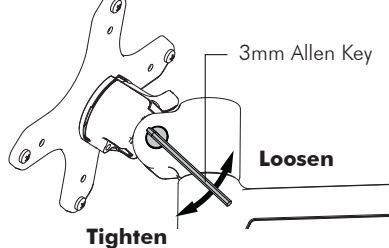

Tighten

Loosen

Note: Support Screen when adjusting tilt.

Pan (Screen angle left/right)

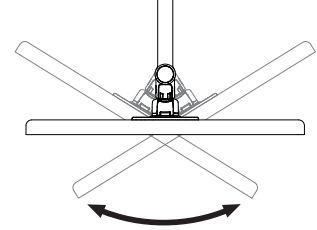

No Allen Key necessary

Ergonomic Guidelines

Many experts believe that the extended use of any computer screen has the potential to cause serious injury to your eyes, neck and back. This can be largely avoided by correctly positioning your display.

Viewing angle: Ergonomists recommend that the optimal position of your display should be slightly below eye level. When looking at the display's centre the user should have a downward visual angle of approximately 10°-20°.

Height: As a guide, the height (**h**) of your display should approximately be as follows:

- Tall Male (Max): 560mm (22")
- Short Male (Min): 368mm (14.5")
- Tall Female (Max): 520mm (20.5")
- Short Female (Min) 356mm (14")

Distance: For visual comfort, a viewing distance (**d**) between 500mm (20") to 750mm (29.5") is recommended.

Tilt Angle: Angular adjustments to reduce reflection on your monitor should range between 5° forward tilt to 15° backward tilt.

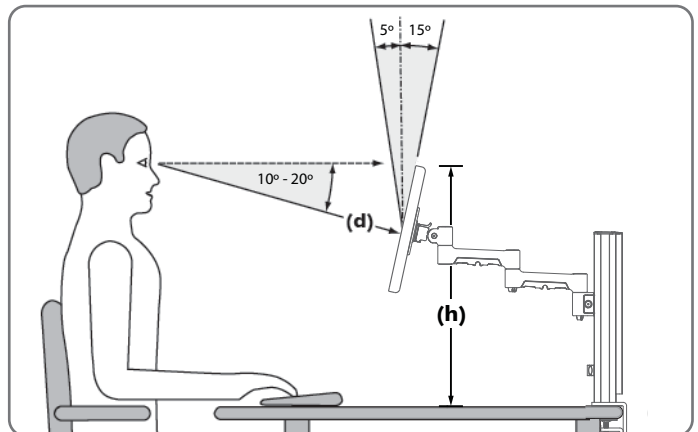

Installation Complete



No portion of this document or any artwork contained herein should be reproduced in any way without the express written consent of Atdec Pty Ltd. Due to continuing product development, the manufacturer reserves the right to alter specifications without notice. Published 06.11.14 ©

SYSTEMA

Systema | 400mm Post

Component Checklist

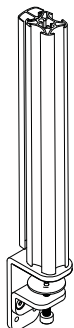

Post Assembly



M8 x 80mm
Bolt Through Screw



M8 x 25mm
CSK screw



Cable Clips (x2)



Pole Cap



Cable Cover Cap



5mm Allen Key



Bolt Through
Washer

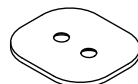

Bolt Through Plate

Tools Required:

- Power Drill
- Phillips Head Screw Driver
- 9mm (0.35") Drill Bit

IMPORTANT INFORMATION:

- ! **IMPORTANT - Install Systema 400mm Post as per installation instruction.**
- ! Systema 400mm Post is compatible with Systema monitor arms SA13, SA46, SA71 & SS
- ! The manufacturer accepts no responsibility for incorrect installation.

Step 1. Check Components

Check what you have received against the component checklist above.

Step 2. Mount Base

Option 1: Mount using Desk Clamp

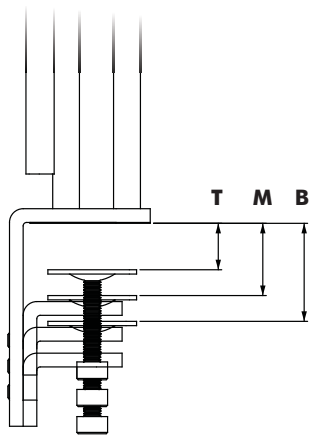

1.1 The Desk Clamp bracket can be repositioned to suit different mounting surface thicknesses. The maximum mounting surface thicknesses supported are listed below from the Top to Middle to Bottom Screw Holes. The Desk clamp bracket comes factory set in the top position.

Top	0 - 38mm (0 - 1.5")
Middle	11 - 53mm (0.43 - 2.08")
Bottom	25 - 68mm (1 - 2.67")

If you need to reposition the desk clamp bracket or you have no access to the rear of your table continue to **Step 1.2**.
 If you DO NOT need to reposition the desk clamp bracket and you have access to the rear of your table skip to **Step 1.5**.

1.2 Remove the M8 x 16mm Countersunk Screws to release the Desk Clamp Bracket.

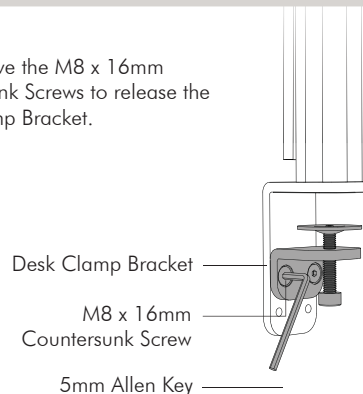

1.3 Place in desired location.

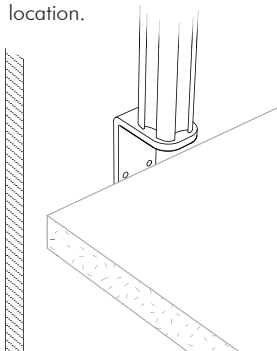

1.4 Reattach Desk Clamp Bracket.

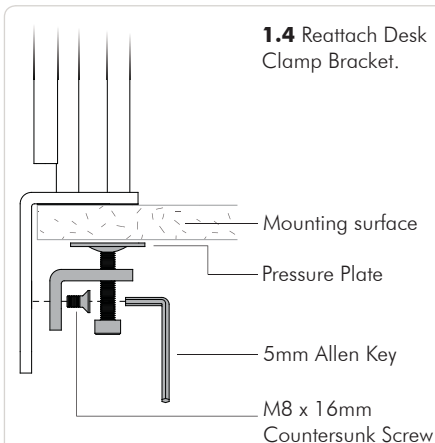

1.5 After positioning your Desk Clamp, screw Pressure Plates in and **Tighten Firmly**.

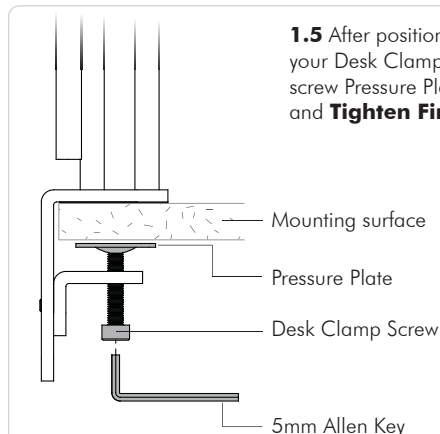

Step 2. Mount Base (cont.)

Option 2: Bolt Through - NOTE: Suits mounting surfaces of up to 63.5mm (2.5") thickness.

2.1 Remove the M8 x 16mm Countersunk Screws to release the Desk Clamp Bracket.

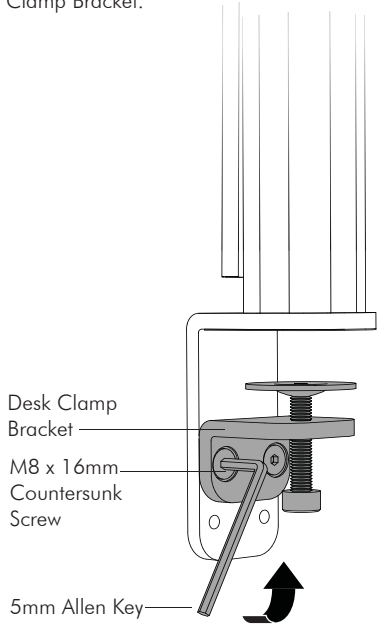

2.2 Remove M8 x 60mm Countersunk Screws to release the post from the Desk Clamp.

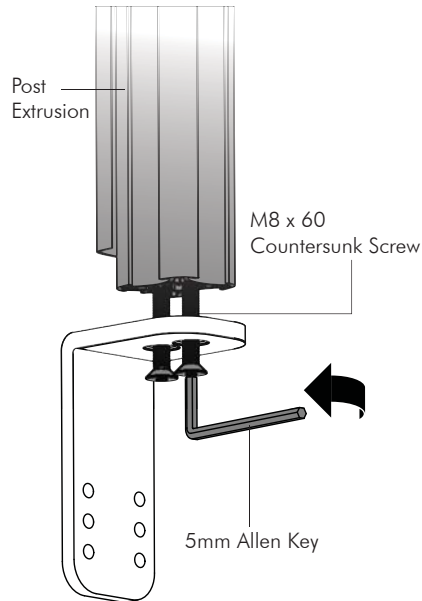

2.3 Drill a 9mm (0.35") hole in the Mounting surface in the desired position and assemble as shown below.

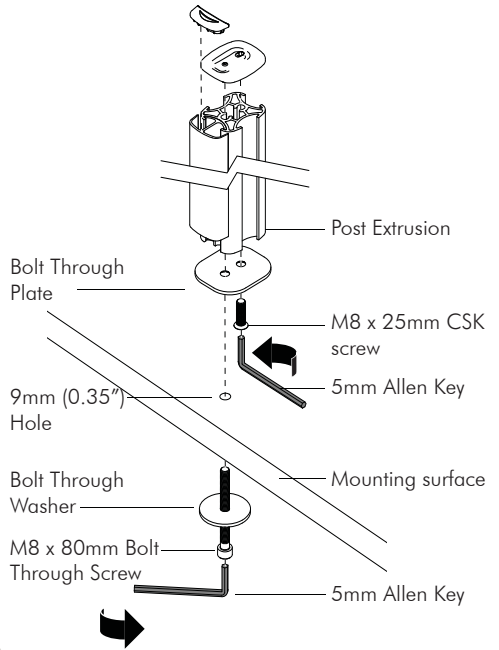

Post placement & Arm configuration

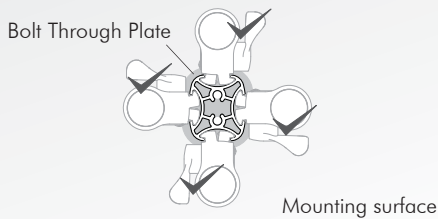

When using the Bolt through method of attachment, arms can be mounted from all four channels and oriented at any angle.

When using the Desk Clamp method of attachment, mounting arms from the rear channel of the post and/or orienting the side mounted arms over the rear of the mounting surface may result in clamp failure.

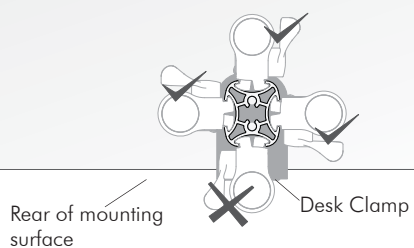

Ergonomic Guidelines

Many experts believe that the extended use of any computer screen has the potential to cause serious injury to your eyes, neck and back. This can be largely avoided by correctly positioning your display.

Viewing angle: Ergonomists recommend that the optimal position of your display should be slightly below eye level. When looking at the display's centre the user should have a downward visual angle of approximately 10°-20°.

Height: As a guide, the height (**h**) of your display should approximately be as follows:

- Tall Male (Max): 560mm (22")
- Short Male (Min): 368mm (14.5")
- Tall Female (Max): 520mm (20.5")
- Short Female (Min) 356mm (14")

Distance: For visual comfort, a viewing distance (**d**) between 500mm (20") to 750mm (29.5") is recommended.

Tilt Angle: Angular adjustments to reduce reflection on your monitor should range between 5° forward tilt to 15° backward tilt.

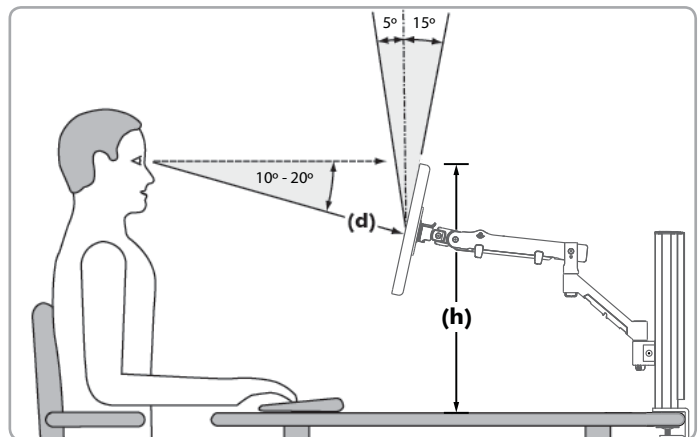

Installation Complete

You are now ready to install your Systema Monitor Arms. Please refer to the Installation Instructions Included with these products.

