

Infinite mounting possibilities



Touchboards

205 Westwood Ave, Long Branch, NJ 07740
Phone: 866-94 BOARDS (26273) / (732)-222-1511
Fax: (732)-222-7088 | E-mail: sales@touchboards.com

ATDEC A-HDA-0818

Robust and ergonomic monitor arm for heavy monitors



Mounting hole pattern:

75 x 75, 100 x 100
optional 200 x 100
(via AC-AP-2010 adaptor plate)



Weight carrying capacity:

8kg (17.6lbs) - 18kg (40lbs)

Ideal for: Heavy duty monitors and all-in-one-PCs in work and gaming environments. Gas-strut assisted arms provide the ultimate in ergonomic support and allow the display to be adjusted effortlessly from a seated position. Touch screen compatible.

Smooth and easy gas-strut assisted movement and three points of articulation optimised for the heavy monitors

Generous up and down tilt (75° and 45° down) to accommodate touch screens

Landscape to Portrait rotation

DESIGNED FOR HEAVY MONITORS

8 - 18KG

17.6- 40 LBS



Quick release/attachment mechanism

Monitor height adjustment range:
From 175mm (6.89")
To 515mm (20.28")

Flexible mounting options:
Bolt Through and Desk
Clamp both included

Top-loading desk clamp
and bolt through attachment
for hard to reach spaces

Comes pre-assembled for quick
and easy installation



Warranty: 5 Years

Product information

Product Code	Load capacity	Material	Colour
A-HDA-0818	8kg -18kg (17.6lbs - 40lbs)	Steel and Aluminium	Black

Package information, single unit

Size	Ship weight	UPC code
48 x 20 x 14 cm (18.9" x 7.87" x 5.51")	3.8kg (8.38lbs)	881493010093

Package information, master pack

Size	Ship weight	UPC code	Units per master pack
49 x 21 x 44 cm (19.29" x 8.27" x 17.32")	12kg (26.46lbs)	881493010109	3

Overall dimensions

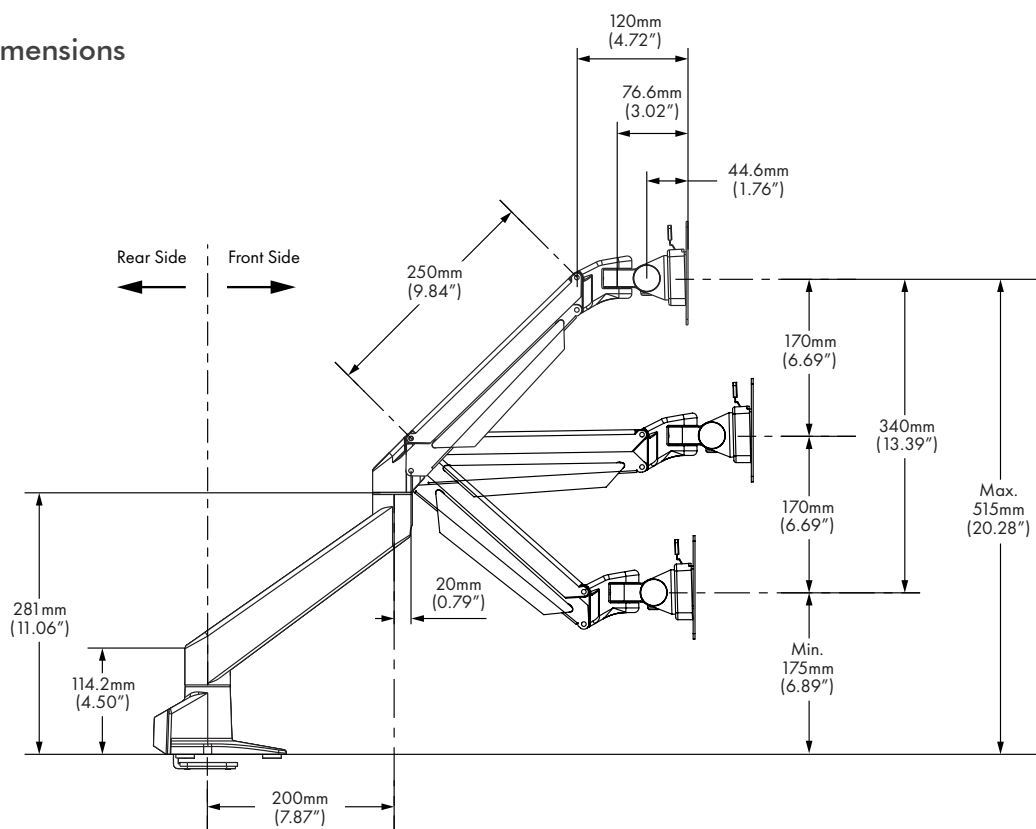

Mounting options

Desk clamp

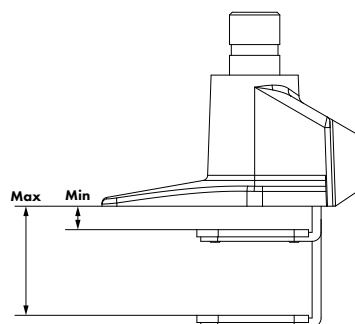

Minimum 10mm (0.39")
Maximum 50mm (1.97")

Bolt through

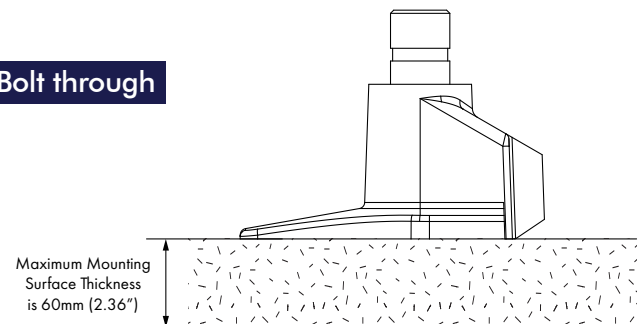

Maximum Mounting
Surface Thickness
is 60mm (2.36")

While all efforts have been made to ensure the information in this brochure was correct as of the date of printing, we reserve the right to change specifications without notice. Please refer to the website for our full range along with the latest details on specifications, compatibility and dealer location. Atdec is a registered trademark with all rights reserved. Copyright November 2016.