

INSTALLATION WITH ATDEC AF- POST

Step 1.

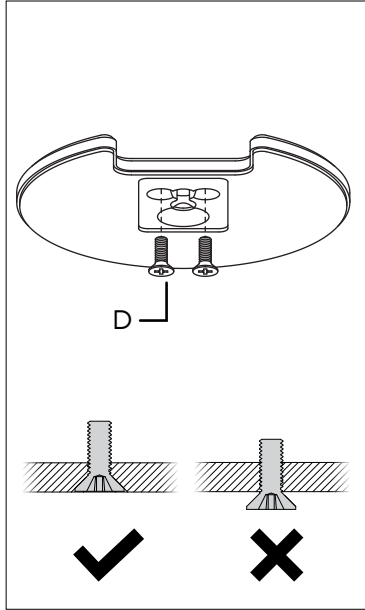

Step 2.

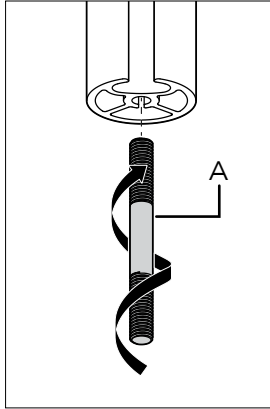

Step 3.

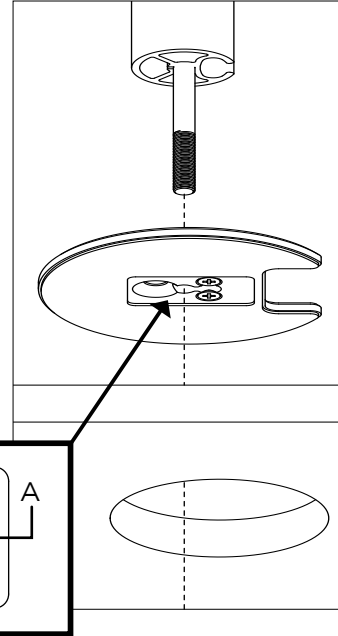

Step 4.

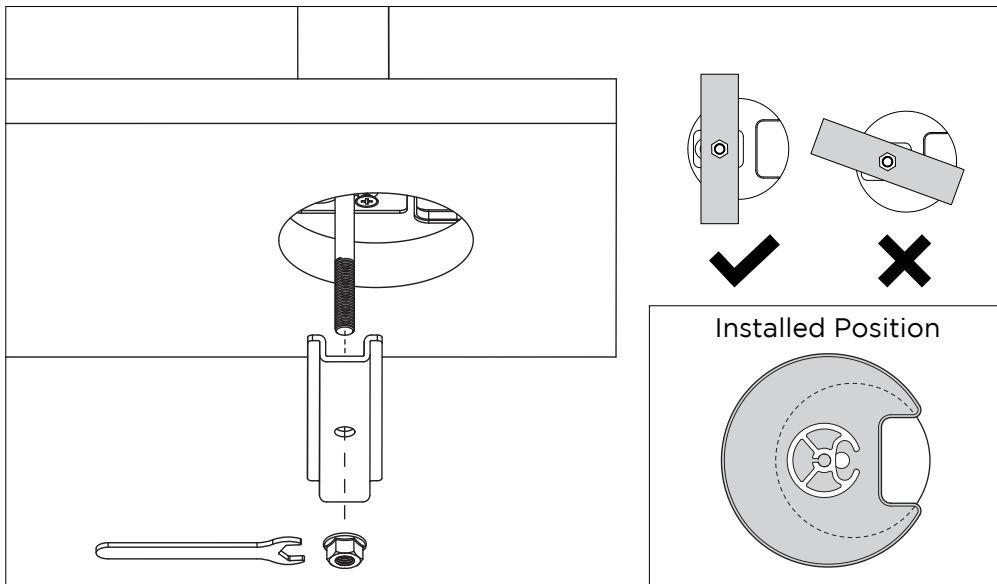

ATDEC

No portion of this document or any artwork contained herein should be reproduced in any way without the express written consent of Atdec Pty Ltd. Due to continuing product development, the manufacturer reserves the right to alter specifications without notice. ©2017/10/13A

ATDEC

Infinite
Mounting
Possibilities

Installation Guide

AC-GC

Grommet Clamp

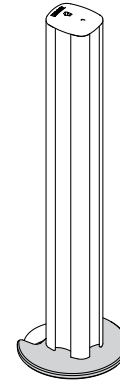

ATDEC AWM-P
Go to Page 2

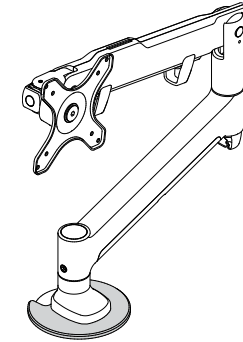

ATDEC AWM-ADB
Go to Page 3

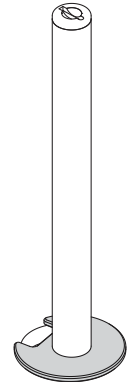

ATDEC AF-
Go to Page 4

COMPONENT CHECKLIST

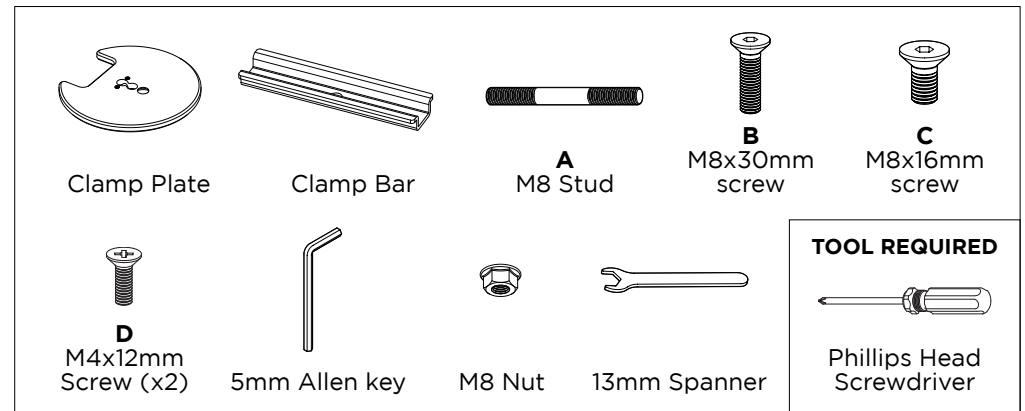

IMPORTANT INFORMATION

- ! **IMPORTANT - Install Atdec Grommet Clamp as per Installation Instructions.**
- ! The manufacturer accepts no responsibility for incorrect installation.
- ! This product is compatible with Atdec products AF- posts, AWM-P posts, AWM-ADB, APM range, VFS range posts, SD-DP range posts.
- ! The product is compatible with grommet hole sizes from 60-80mm
- ! The product is compatible with desk thicknesses from 18-36mm

INSTALLATION WITH ATDEC AWM-P Posts

Step 1. Assemble Post to Grommet Clamp

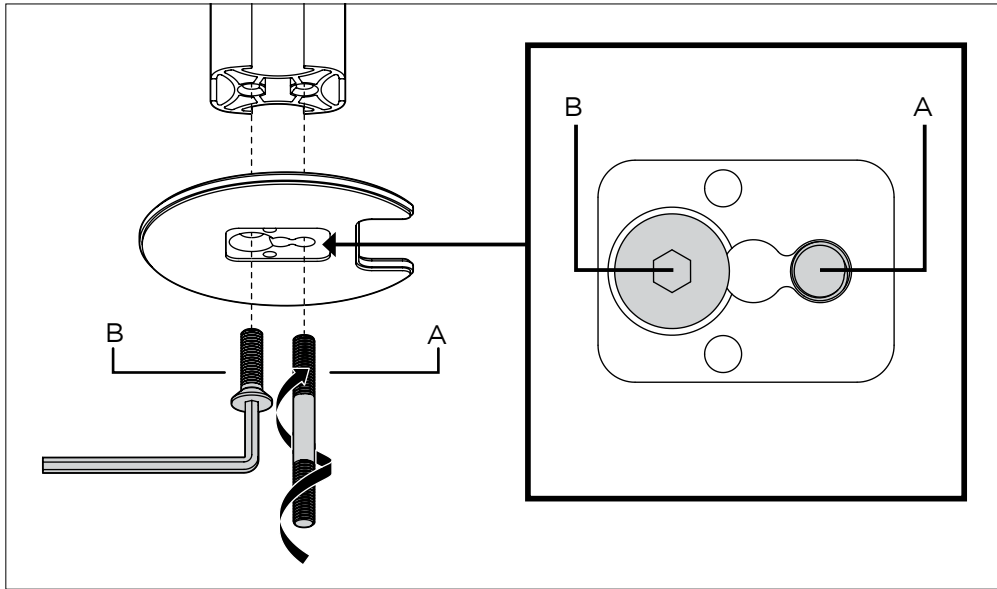

Step 2. Install Grommet Clamp on desk

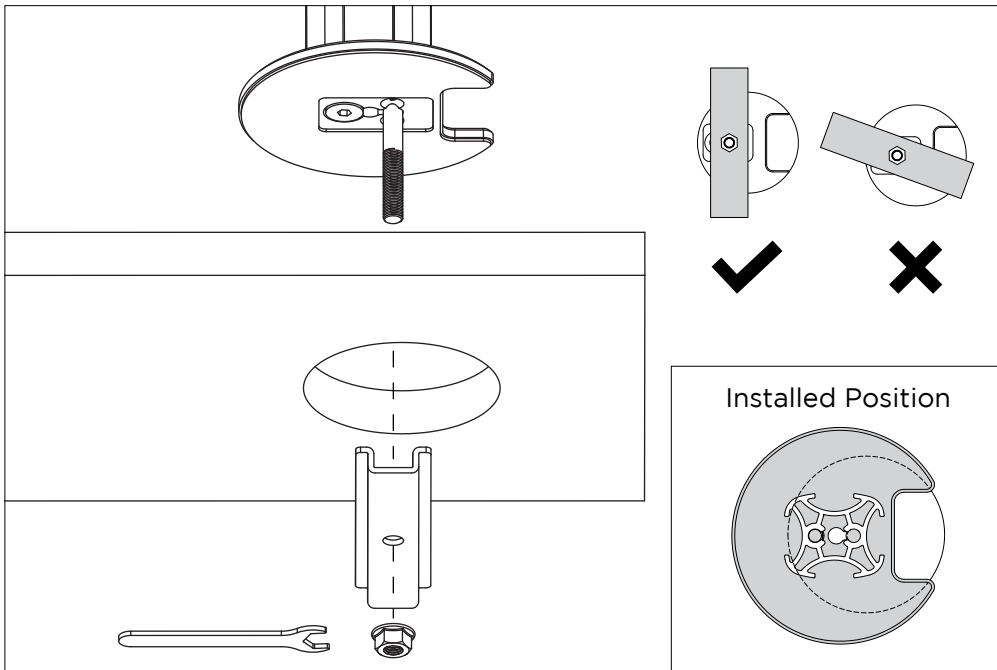

INSTALLATION WITH ATDEC AWM-ADB

Step 1. Assemble Base to Grommet Clamp

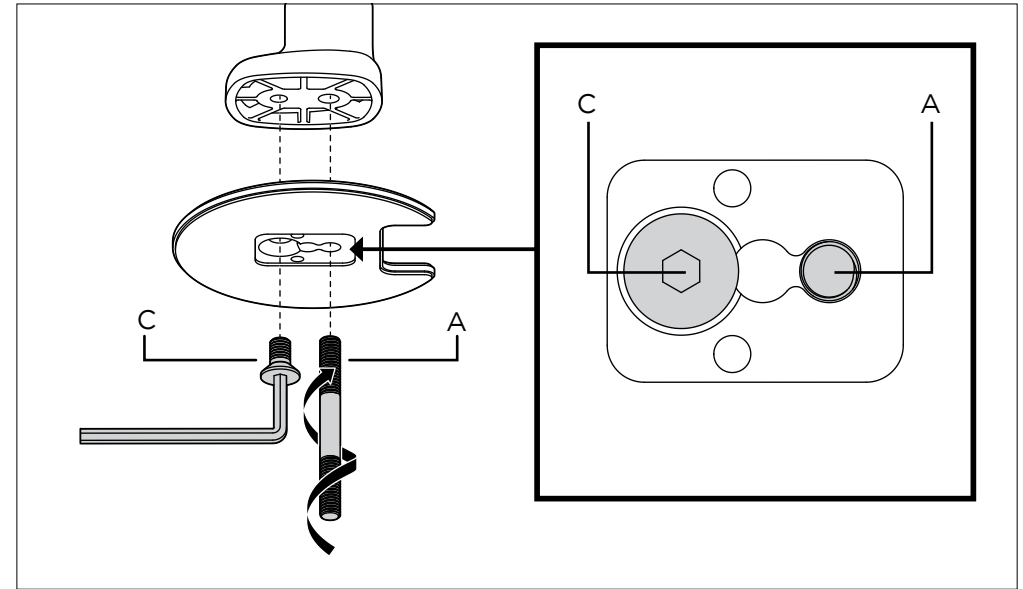

Step 2. Install Grommet Clamp on desk

