

710 Arm

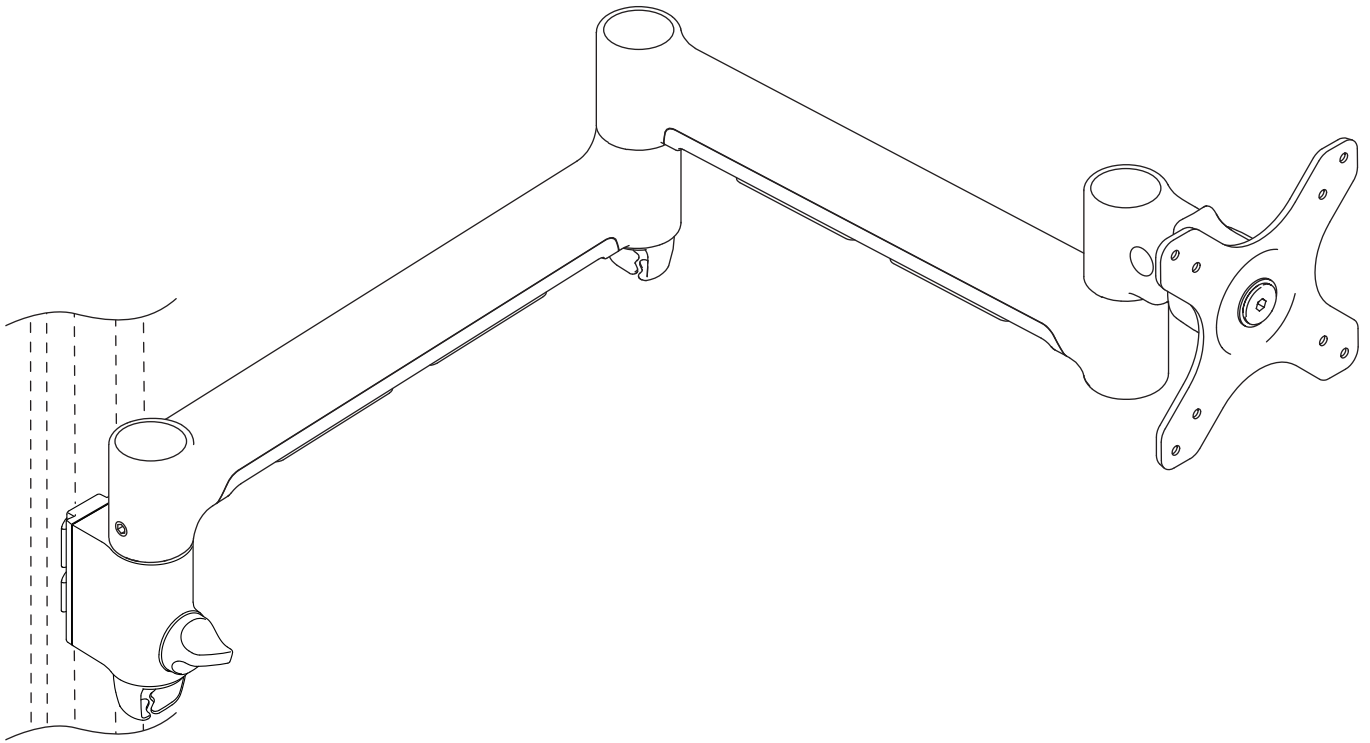

COMPONENT CHECKLIST

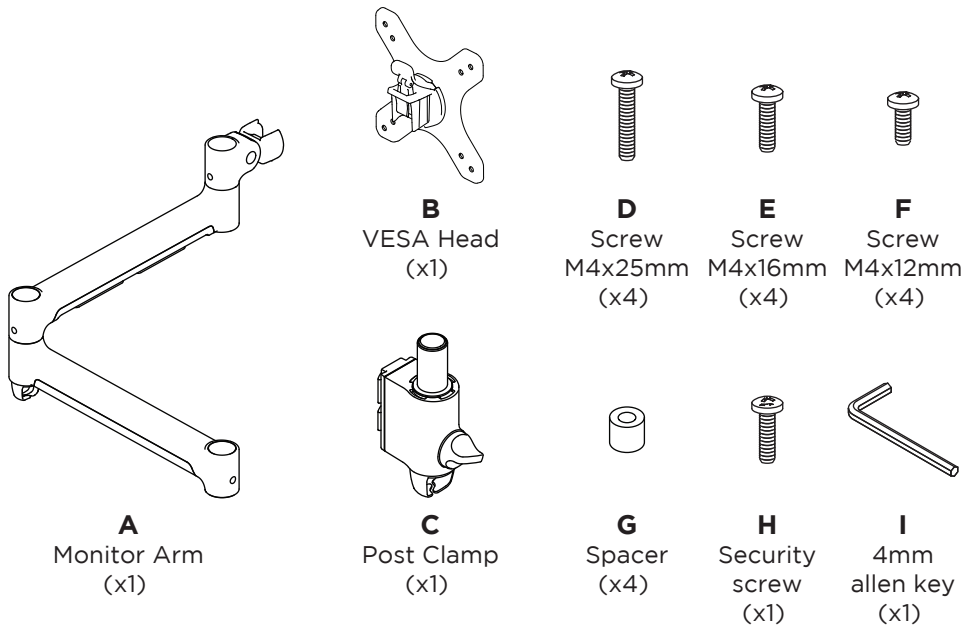

REQUIRED TOOLS

- Phillips Head Screwdriver

WEIGHT RANGE

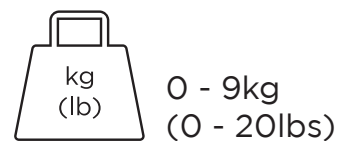

IMPORTANT INFORMATION

- ! Please ensure this product is installed as per these installation instructions.
- ! The manufacturer accepts no responsibility for incorrect installation.
- ! This product is compatible with Atdec AWM Series products.

1. Fix clamp to Post or Wall Channel

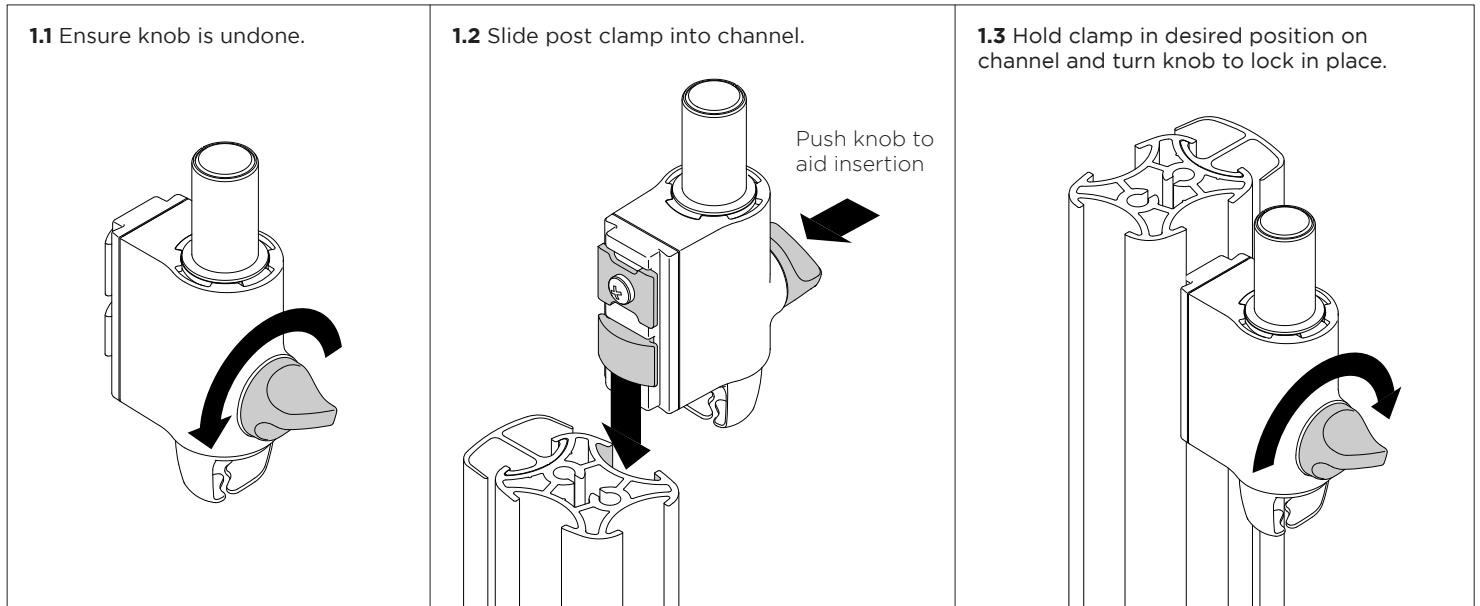

2. Set arm rotation to 180° (optional)

Note rotation is set to 360° by default.

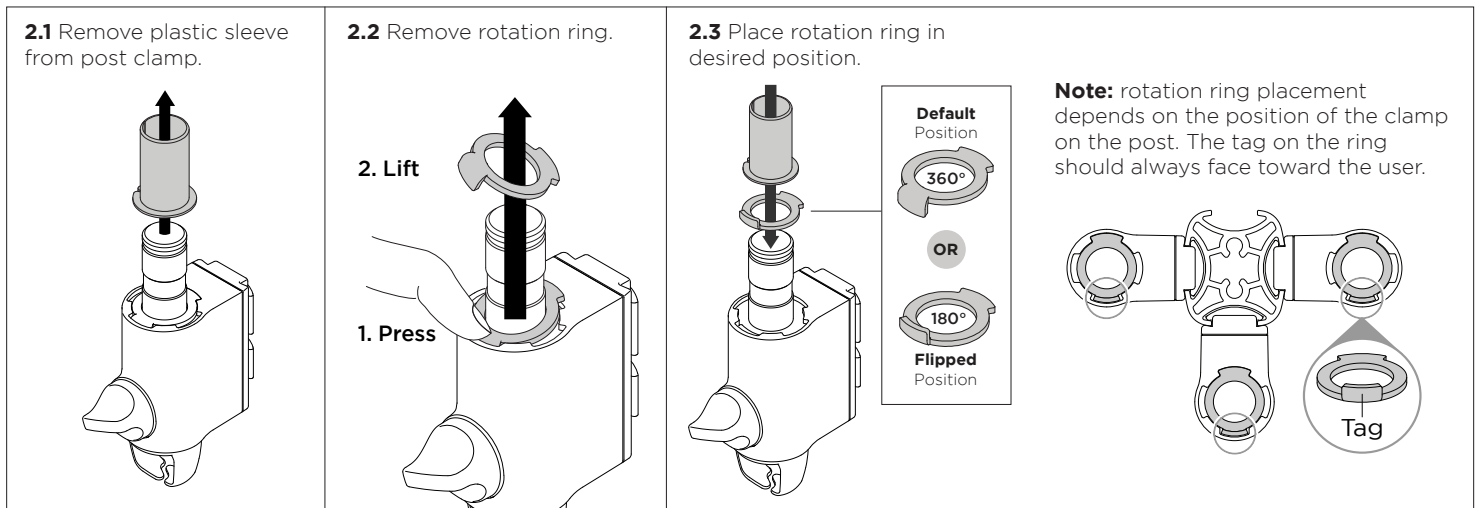

3. Fit arm onto post clamp

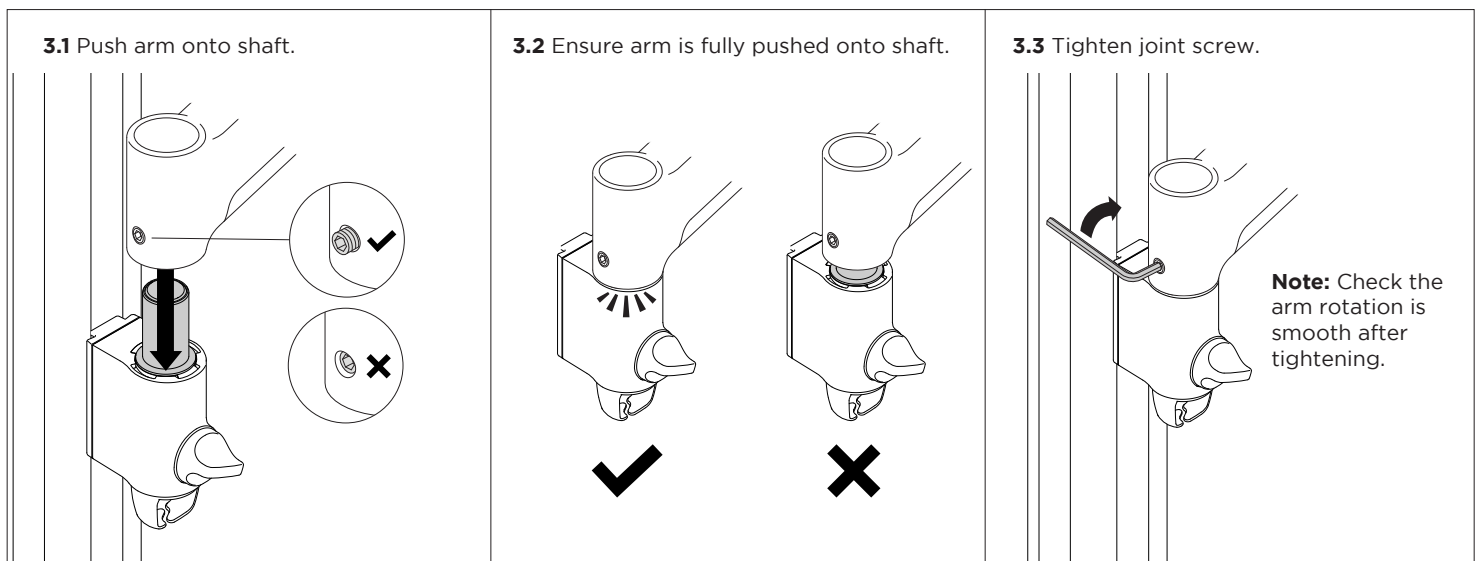

4. Attach VESA head to monitor

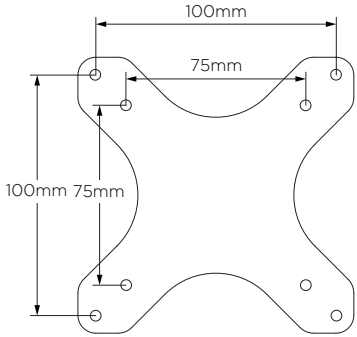
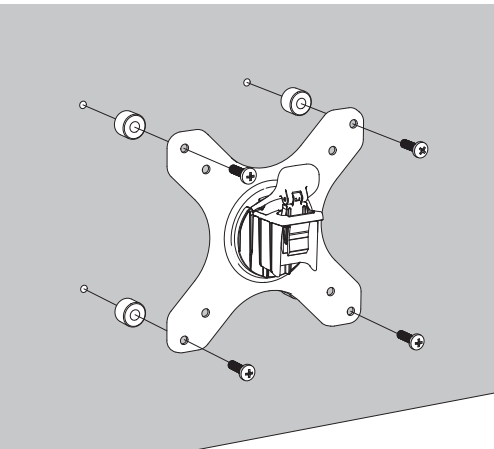
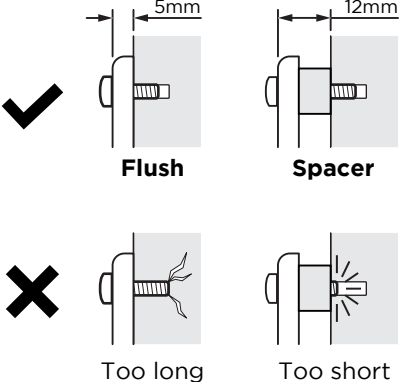
<p>4.1 VESA mounting compatibility</p>  <p>Note: For other sizes, use a suitable adaptor plate (sold separately).</p>	<p>4.2 Screw the VESA head onto monitor</p>  <p>Note: spacers may be required for curved, recessed or uneven monitor surfaces.</p>	<p>4.3 Ensure the correct screw length is used to attach the monitor.</p>  <p>✓ Flush (5mm) Spacer (12mm)</p> <p>✗ Too long Too short</p>
--	--	---

5. Mount monitor

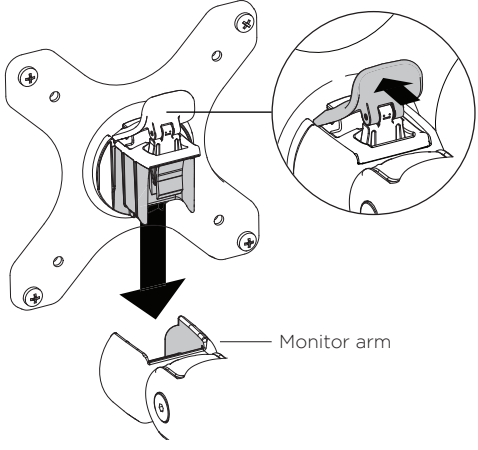
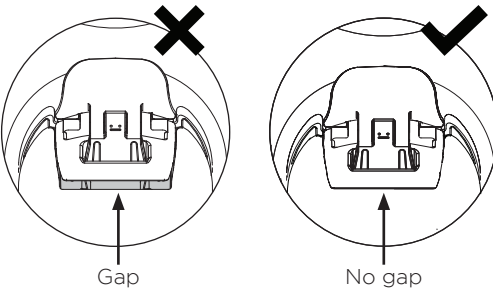
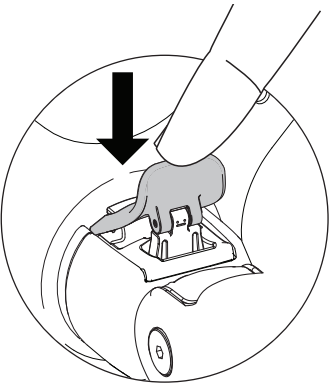
<p>5.1 Insert VESA head into the monitor arm</p>  <p>Monitor arm</p>	<p>5.2 Ensure that the VESA head sits flush within the monitor arm. There should be no gap.</p>  <p>Gap No gap</p>	<p>5.3 Push the lever down to secure monitor to the arm assembly</p> 
--	---	--

6. Adjust tilt tension & Install security screw

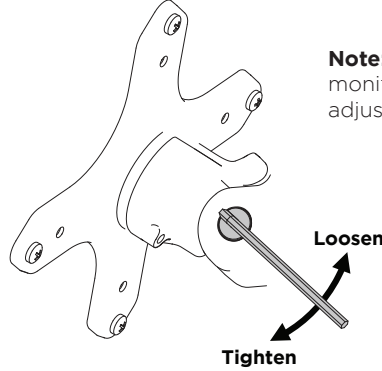
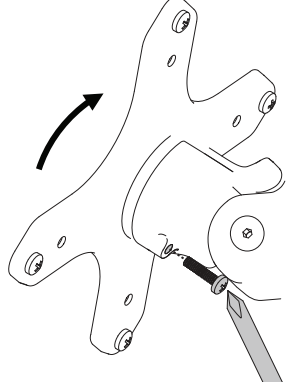
<p>6.1 Use the allen key to adjust the tilt tension until the monitor holds in a vertical position at the end of the arm.</p>  <p>Note: Support monitor while adjusting.</p> <p>Loosen</p> <p>Tighten</p>	<p>6.2 OPTIONAL security screw To install the optional security screw tilt the head upwards</p> 
--	--

7. Monitor arm cable management

7.1 Plug cables into the monitor and route the cables down the arm using the cable hooks and clips.

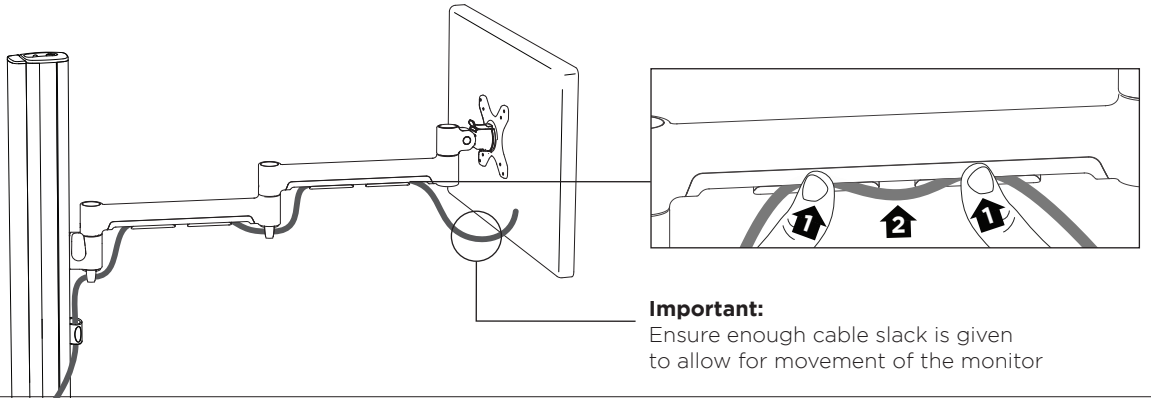

8. Post cable management

8.1 Push the cable down into the cable clip

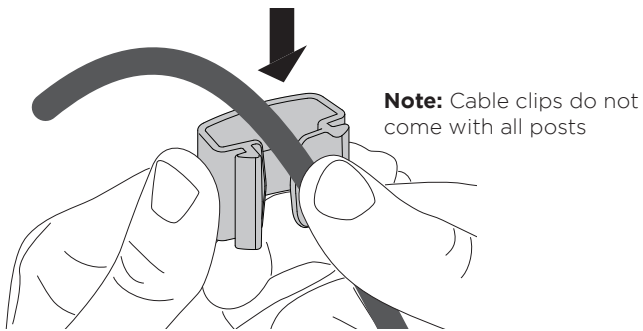

8.2 Push cable clip into post channel

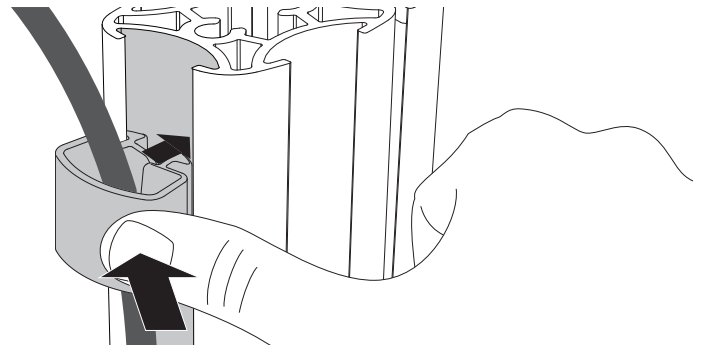

8.3 Recommended post cable cover position for double or triple arm set-ups

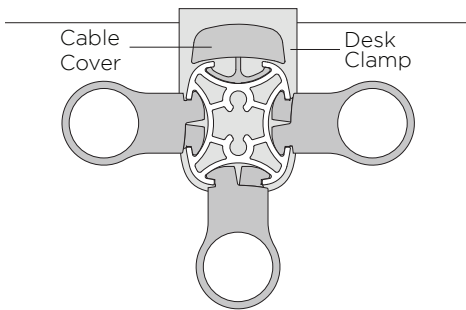

8.4 To reposition the cable cover, pull it straight up and out of the post and insert it into any of the available channels

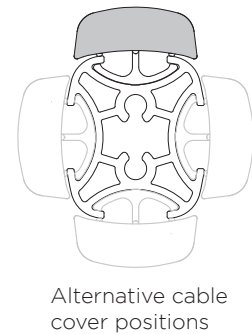
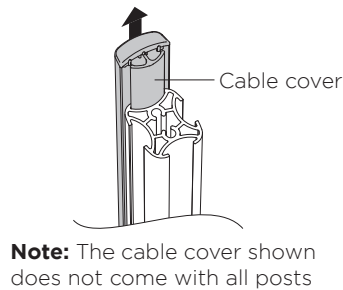

8.5 Loop cable and insert into cable cover

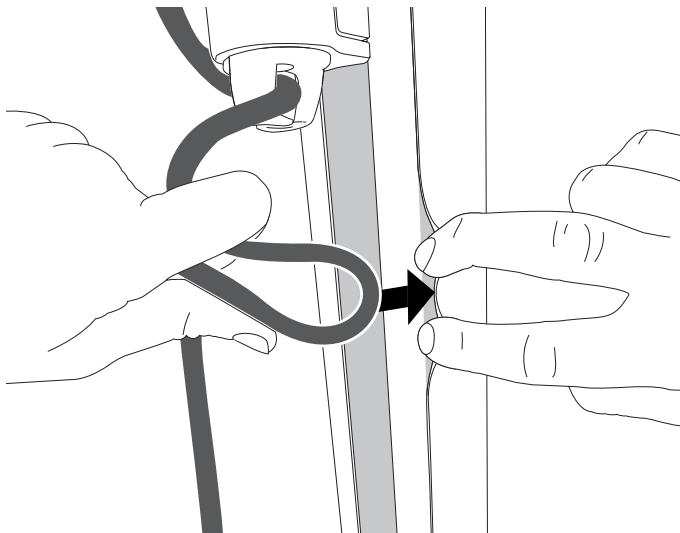

8.6 Feed remaining cable into cover

