

C Clamp

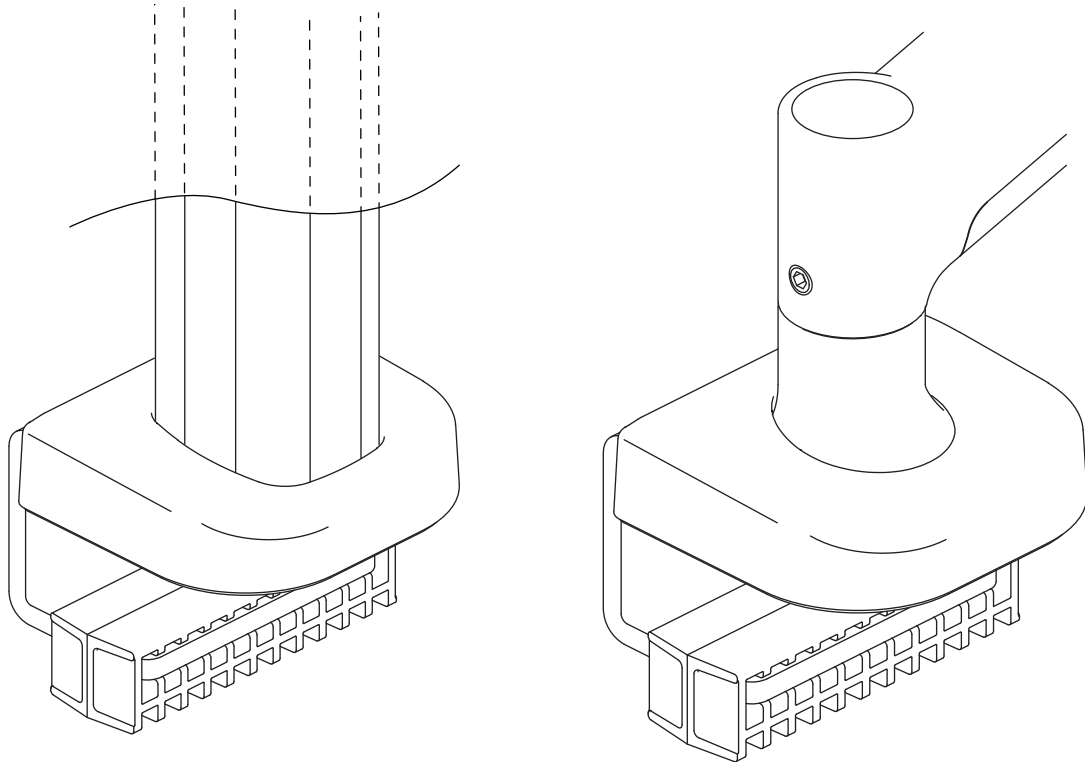

COMPONENT CHECKLIST

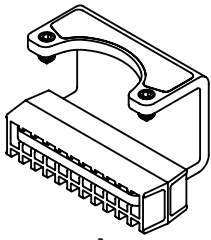

A
C Clamp Bracket
(x1)

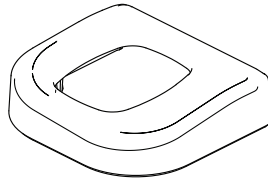

C
Cover for Post
(x1)

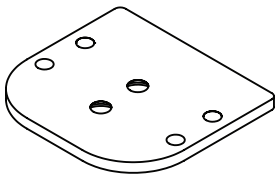

B
C Clamp Plate
(x1)

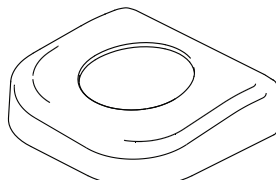

D
Cover for Base
(x1)

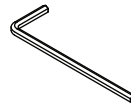

E
4mm
Allen key
(x1)

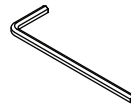

F
5mm
Allen key
(x1)

REQUIRED TOOLS

- All tools supplied

IMPORTANT INFORMATION

- ! Please ensure this product is installed as per these installation instructions.
- ! This product is compatible with Atdec modular (AWM) products.
- ! The manufacturer accepts no responsibility for incorrect installation.

1. C Clamp overview

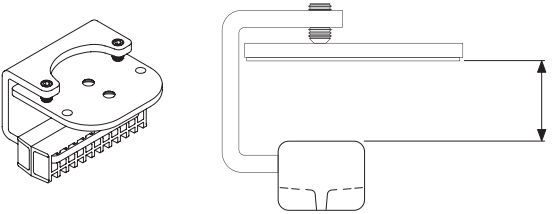
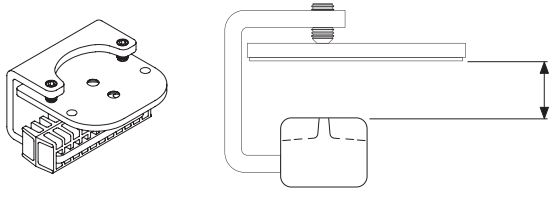
<p>1.1 Default - This is the "out of the box" configuration</p>  <p>MIN THICKNESS - 25mm (1") MAX THICKNESS - 33mm (1⁵/₁₆")</p>	<p>1.2 Inverted - The C Clamp can be reconfigured for thicker surfaces</p>  <p>MIN THICKNESS - 18mm (1¹/₁₆") MAX THICKNESS - 25.8mm (1")</p>
--	--

2. Re-configure Clamp

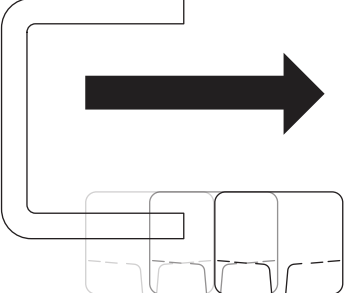
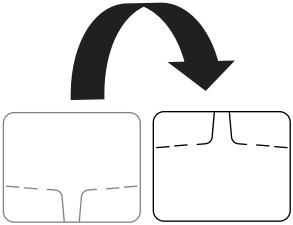
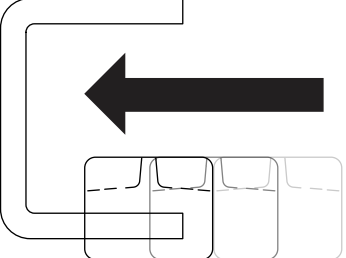
<p>2.1 Slide pad off</p> 	<p>2.2 Invert pad</p> 	<p>2.3 Slide pad back on</p> 
--	--	---

3. Post mount configuration

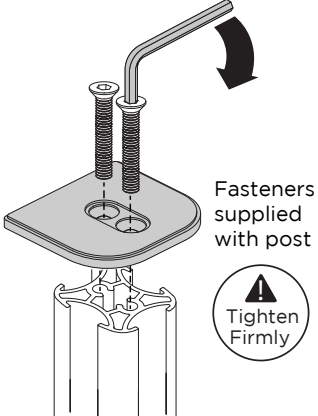
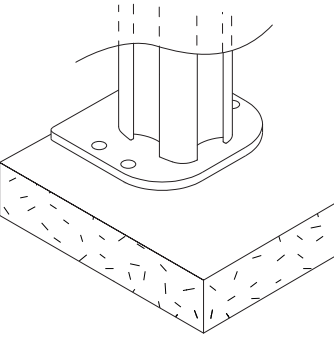
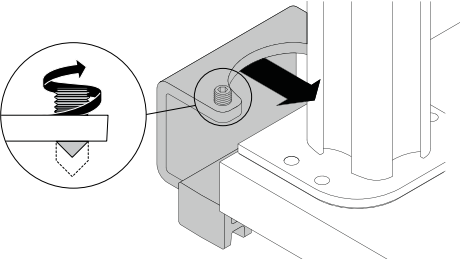
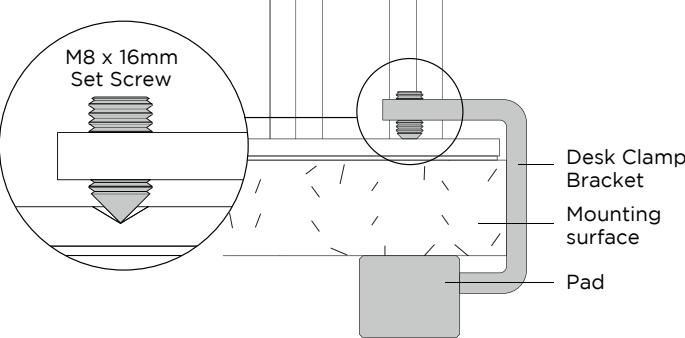
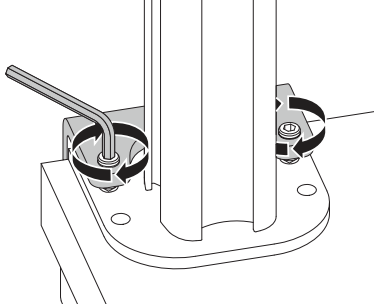
<p>3.1 Attach plate to post</p>  <p>Fasteners supplied with post</p> <p>Tighten Firmly</p>	<p>3.2 Place in desired location</p> 	<p>3.3 Slide the C Clamp bracket over the plate and position screw tips in the indents on the base plate</p>  <p>Note: You may need to un-screw the set screws out of the plate using the allen key</p>
<p>3.4 Check the set screws are mounted in position. Also check the desk clamp bracket is positioned tight up against the mounting surface edge</p>  <p>M8 x 16mm Set Screw</p> <p>Desk Clamp Bracket</p> <p>Mounting surface</p> <p>Pad</p>		<p>3.5 Tighten the set screws firmly and evenly on both sides of the desk clamp bracket.</p> 

4. Installing the clamp cover to post

4.1 Remove the cable cover by pulling it straight up and out of the post. Remove top cap if already installed

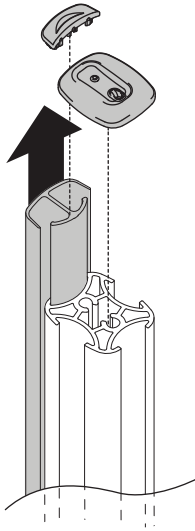

4.2 Locate the C Clamp cover over the post. Guide over the holes in the base plate and gently apply pressure on the cover until it clicks into place

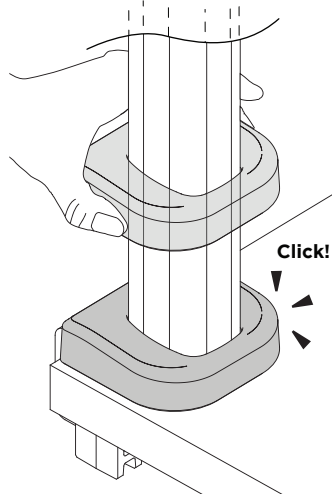

4.3 Re-attach the cable cover by sliding it into the post channel. Fit the pole and cover caps back on.

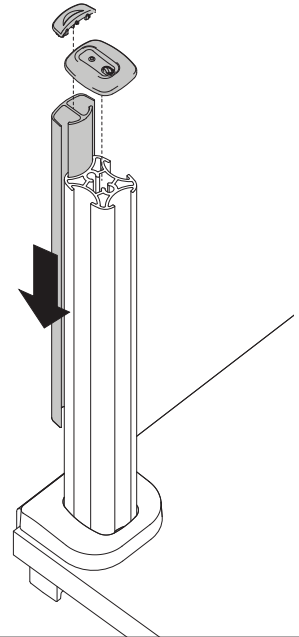

5. Base mount installation

5.1 Attach plate to base

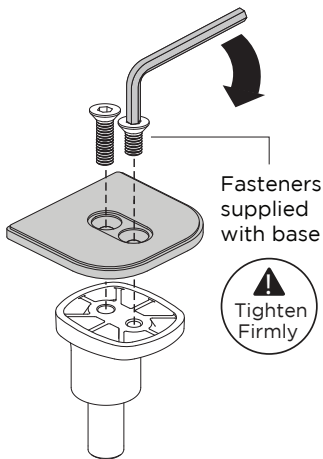

5.2 Place the base and plate in desired location

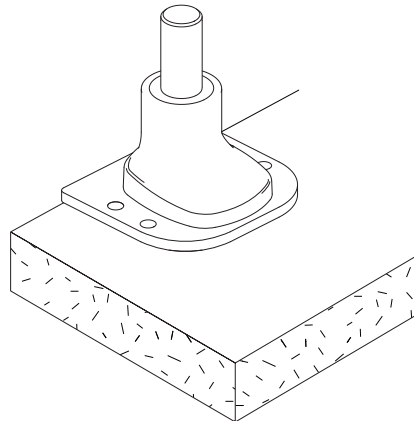

5.3 Slide the bracket onto the base plate and position screw tips in the indents on the base plate

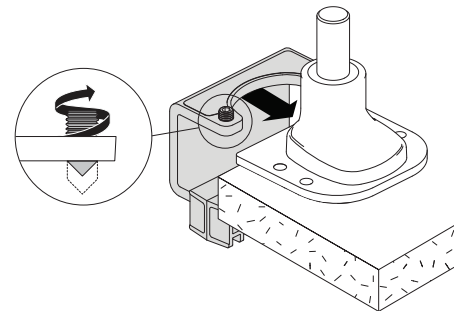

Note: You may need to un-screw the set screws out of the plate using the allen key

5.4 Check the set screws are mounted in position. Also check the desk clamp bracket is positioned tight up against the mounting surface edge

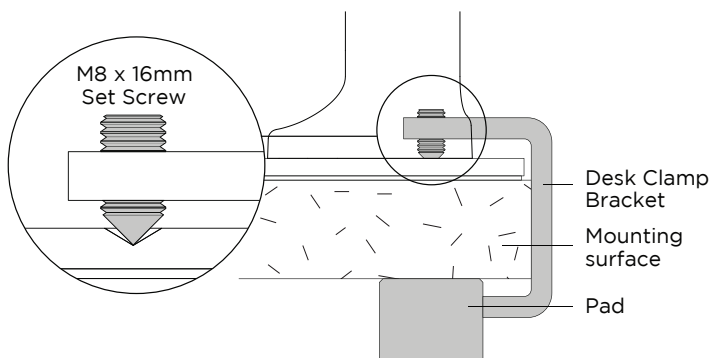

5.5 Tighten the set screws **firmly** and **evenly** on both sides of the desk clamp bracket

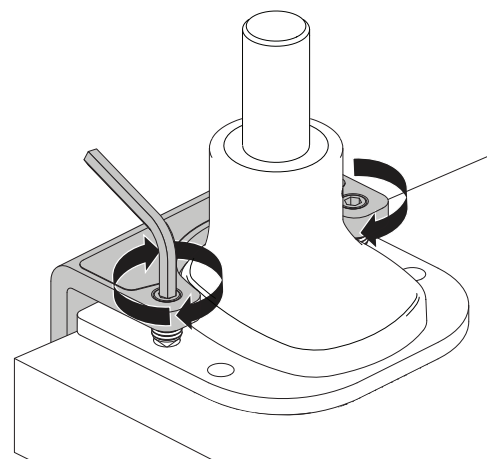

6. Installing the clamp cover to base

6.1 Locate the Cover for Base over the base. Guide over the holes in the base plate and gently apply pressure on the cover until it clicks into place.

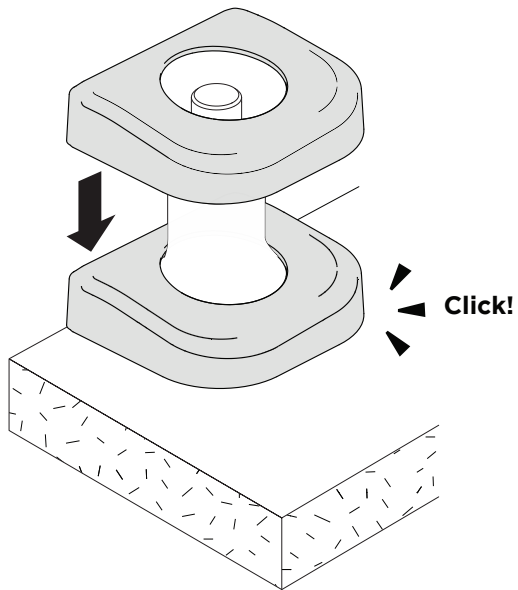

6.2 Installation Complete

To continue with installation of your monitor arm, refer to your monitor arm's installation guide.

