

Dual Crossbar

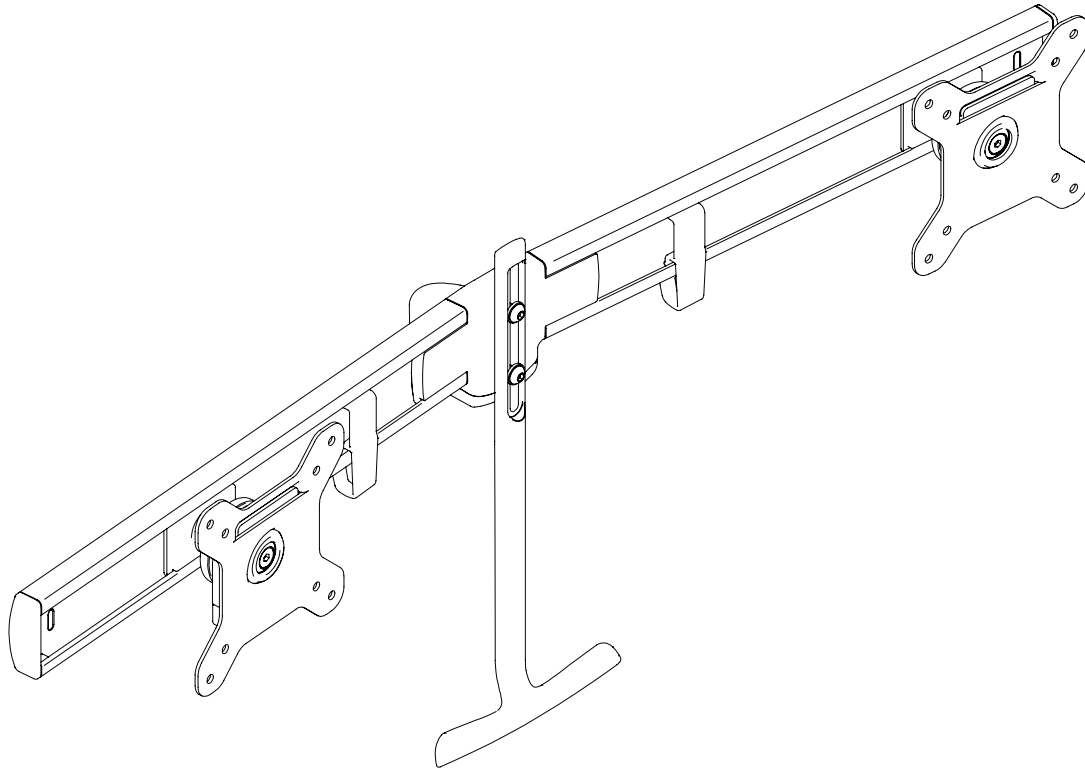

COMPONENT CHECKLIST

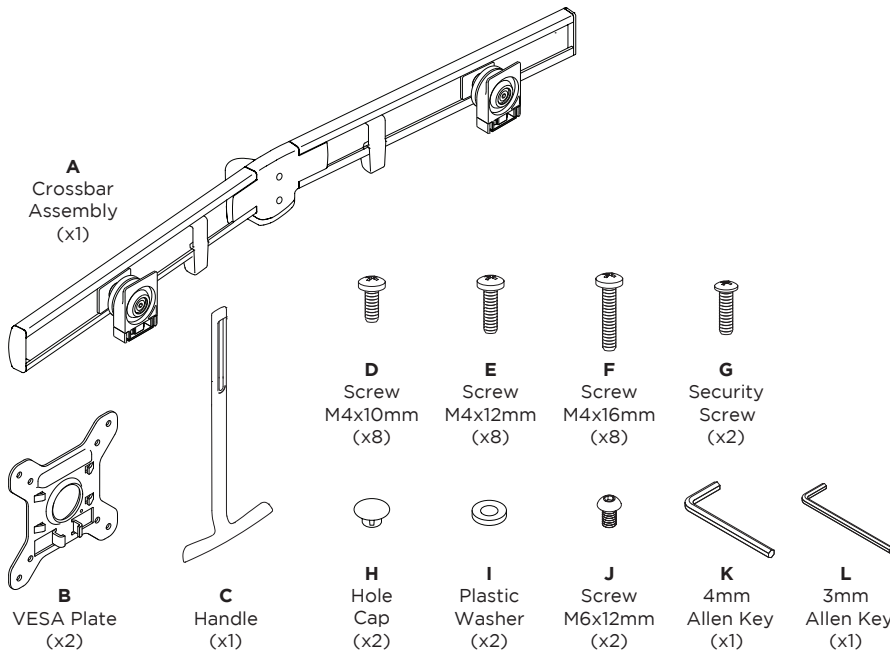

Desk

REQUIRED TOOLS

- Phillips Head Screwdriver

WEIGHT RANGE

2 - 7kg
(4.5 - 15lbs)
per monitor

Monitor weight should be within the weight range of all modular elements that make up the complete monitor mounting solution.

IMPORTANT INFORMATION

- ! Please ensure this product is installed as per these installation instructions.
- ! Curved monitors, deep devices (such as all-in-one PCs) and offset VESA locations exert additional leverage that can exceed the capacity of the mount even though the monitor weight may be within the stated range.
- ! The manufacturer accepts no responsibility for incorrect installation.
- ! This product is compatible with AWM Series monitor arm products.

1. Mount crossbar onto arm

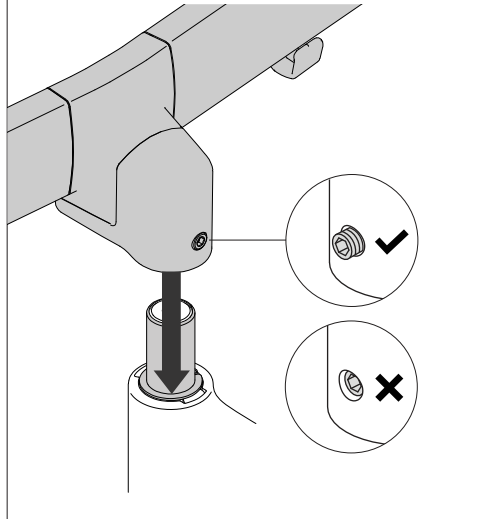
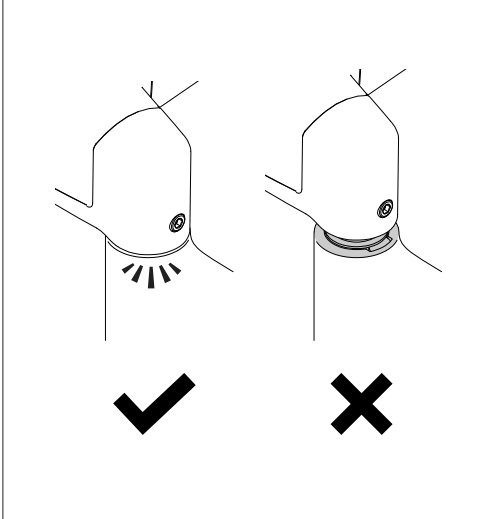
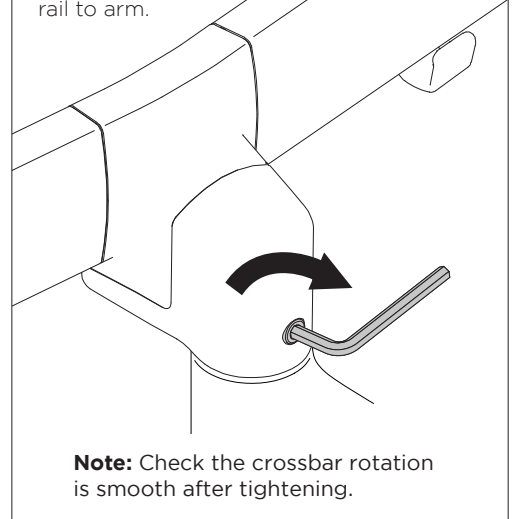
<p>1.1 Push crossbar onto shaft at end of arm.</p> 	<p>1.2 Ensure crossbar is fully pushed onto shaft.</p> 	<p>1.3 Tighten joint screw to secure rail to arm.</p>  <p>Note: Check the crossbar rotation is smooth after tightening.</p>
--	--	--

2. Attach handle (Optional)

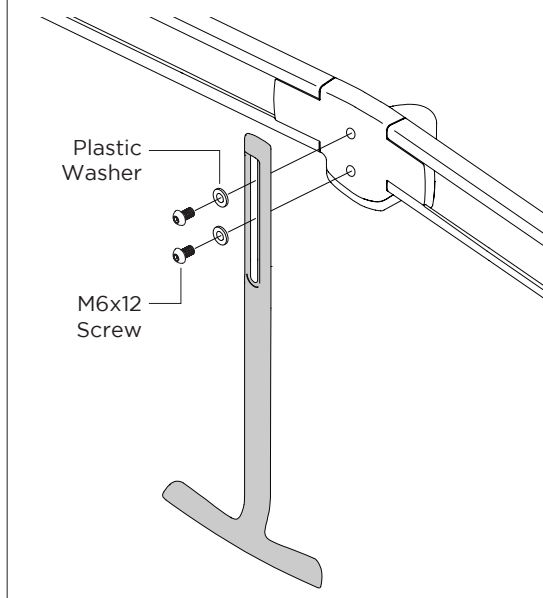
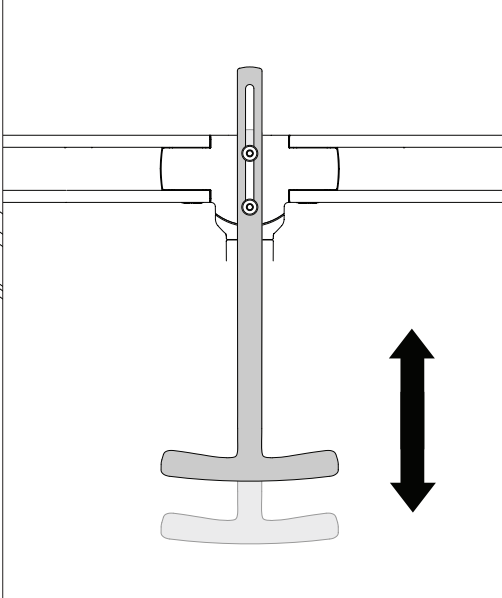
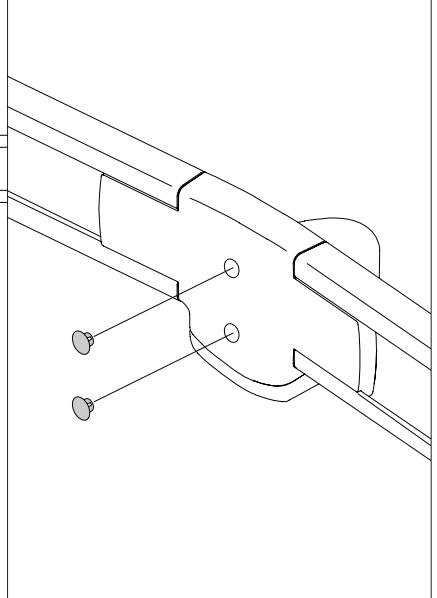
<p>2.1 Use the 4mm allen key to loosely fasten the handle onto the crossbar.</p>  <p>Plastic Washer</p> <p>M6x12 Screw</p>	<p>2.2 Adjust handle to a height that suits the monitors, then tighten the two screws.</p> 	<p>2.3 If not using handle fit hole caps.</p> 
--	---	---

3. Attach VESA plates to monitors

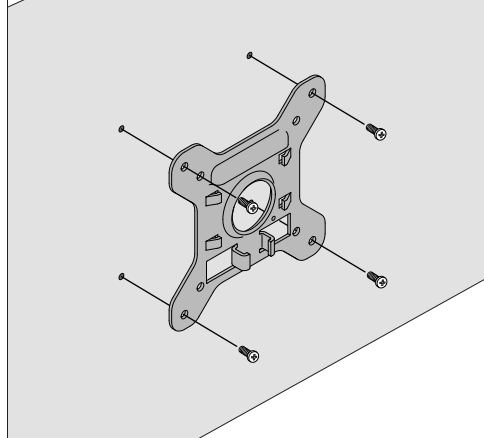
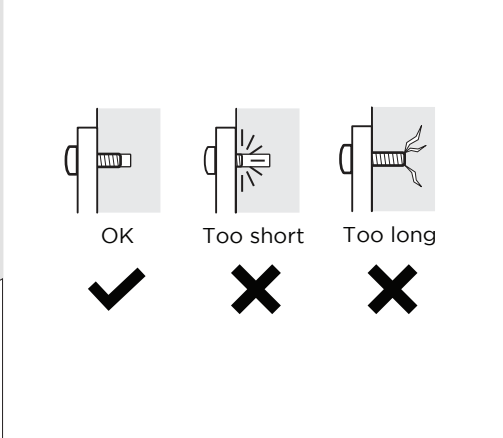
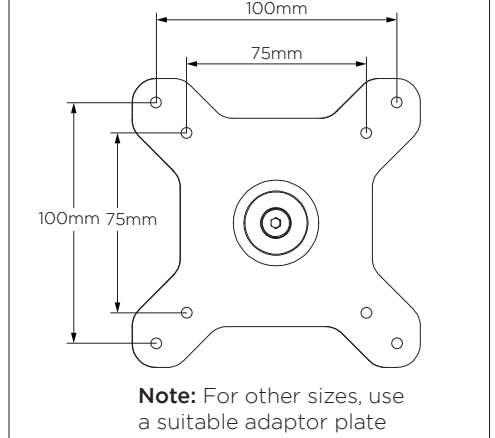
<p>3.1 Screw VESA plates onto the monitors.</p> 	<p>3.2 Ensure suitable screw length is used.</p>  <p>OK</p> <p>Too short</p> <p>Too long</p>	<p>3.3 VESA mounting compatibility</p>  <p>100mm</p> <p>75mm</p> <p>100mm</p> <p>75mm</p> <p>Note: For other sizes, use a suitable adaptor plate</p>
---	---	---

4. Mount monitors onto crossbar

4.1 Hook the top of the VESA plate onto the ball joint mount.

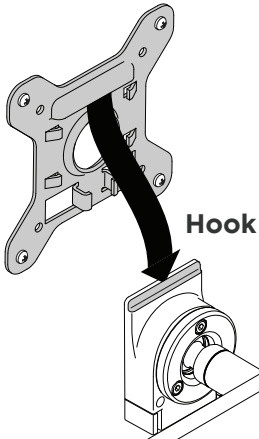

4.2 Gently push the bottom of the monitor until the VESA plate locks into place.

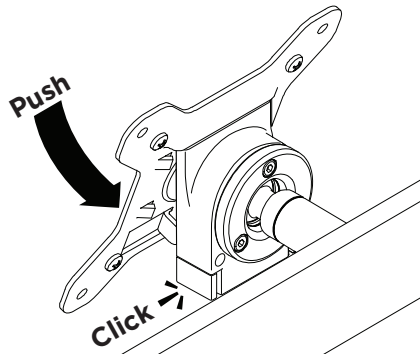

4.3 OPTIONAL security screw

Tilt the monitor upwards to install the security screw.

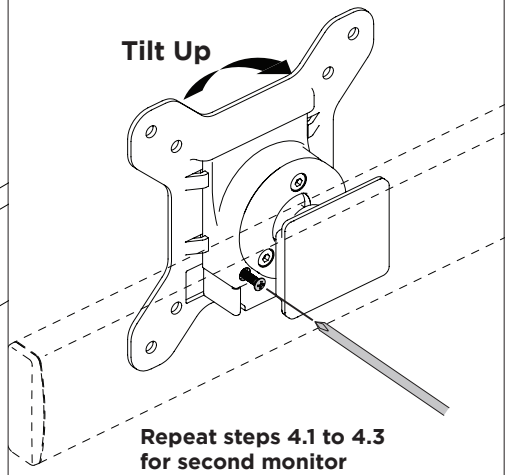

5. Adjust the ball joint tension

5.1 If the monitors are not holding position or are stiff to move, adjust the tension plate by tightening or loosening the three screws.

Note: Support the monitor while making adjustments.

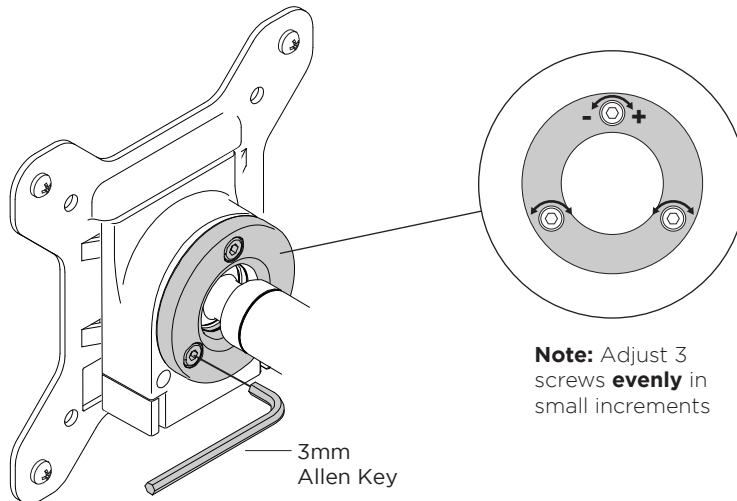

6. Install Cables

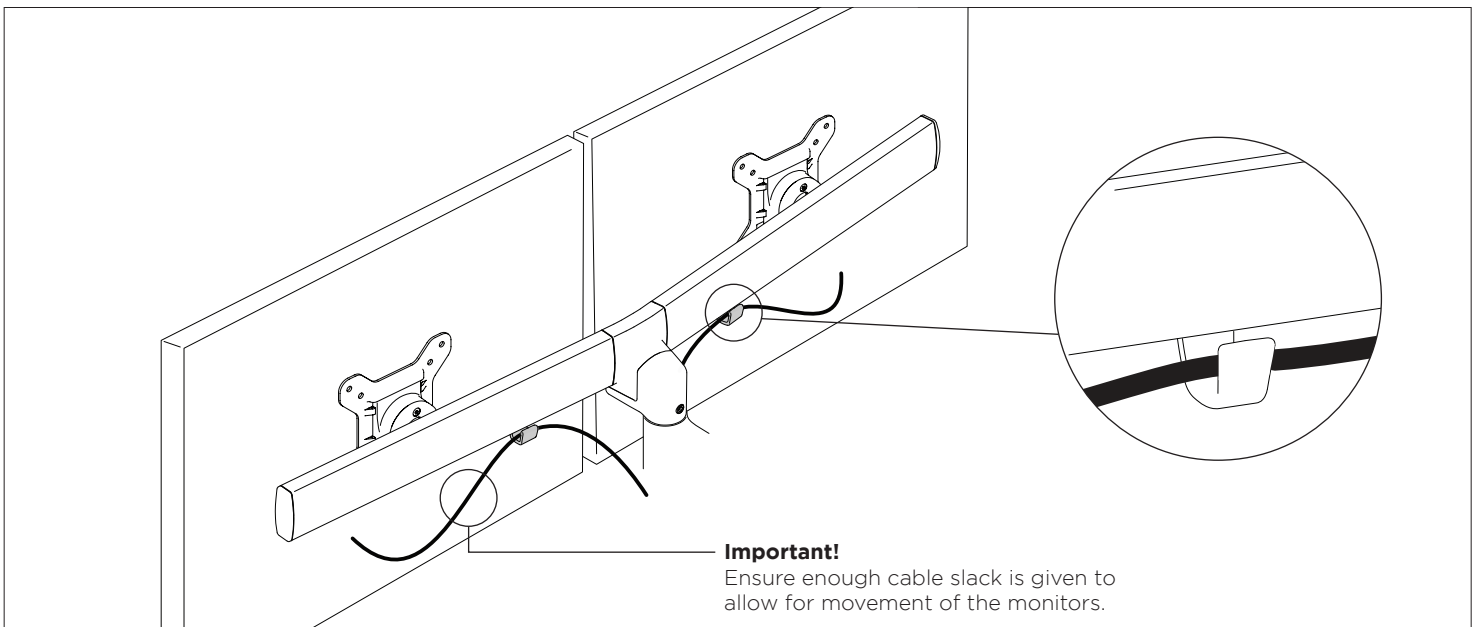

7. Adjust horizontal position of monitors

7.1 Slide the monitors along the crossbar until they are positioned centrally in the desired position.

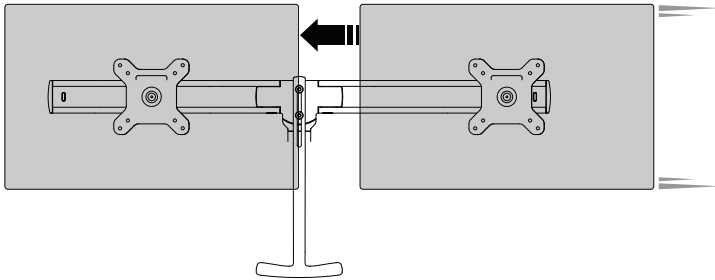

7.2 Monitors can also be rotated to portrait position.

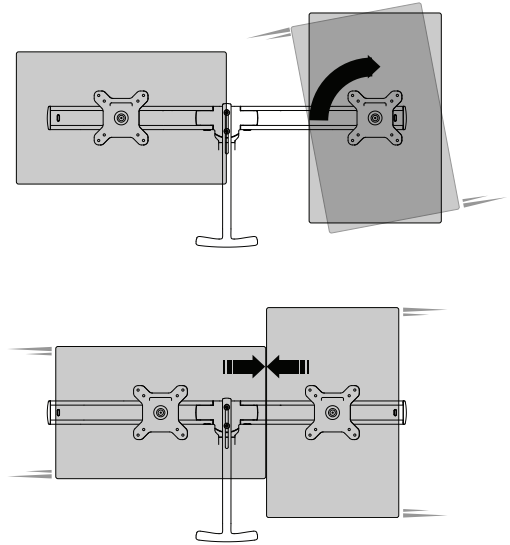

8. Adjust level of crossbar

8.1 Rotate the crossbar so that it sits parallel to the worksurface.

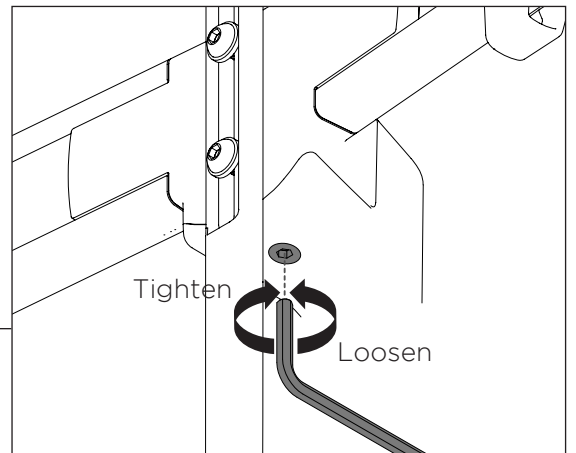
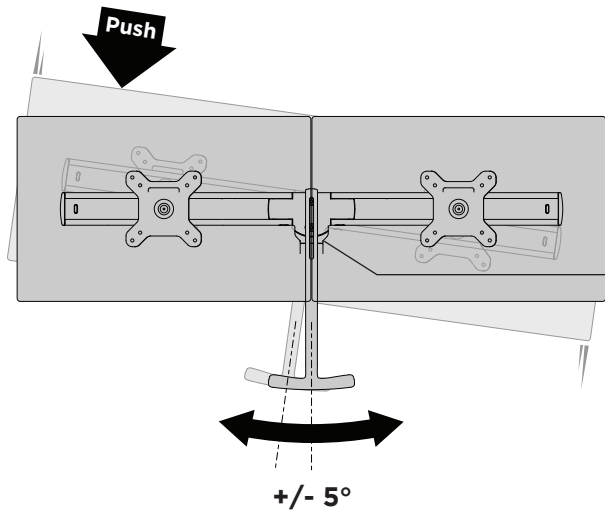

OPTIONAL If the crossbar rotation is too loose or stiff, adjust the tension screw under the centre of the crossbar.

9. Adjust monitor angle

