

Heavy Duty VESA Tilt Head

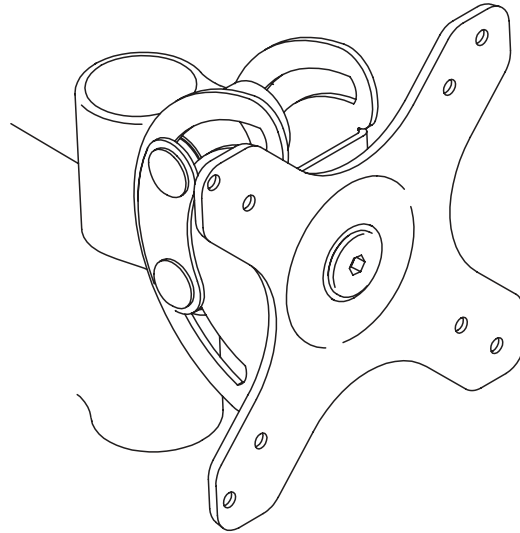

COMPONENT CHECKLIST

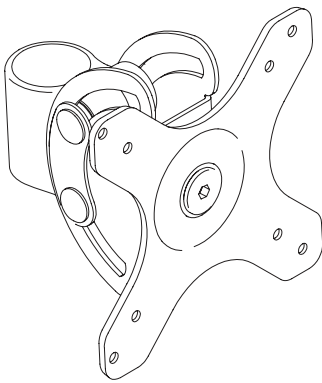

A
Heavy Duty
Tilt Head
(x1)

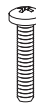

B
Screw
M4x25mm
(x4)



C
Screw
M4x16mm
(x4)



D
Screw
M4x12mm
(x4)



E
Spacer
(x4)



F
4mm
allen key
(x1)



REQUIRED TOOLS

- Phillips Head Screwdriver

WEIGHT RANGE

0 - 18kg
(0 - 40lb)

Monitor weight should be within the weight range of all modular elements that make up the complete monitor mounting solution.

IMPORTANT INFORMATION

- ! Please ensure this product is installed as per these installation instructions.
- ! Curved monitors, deep devices (such as all-in-one PCs) and offset VESA locations exert additional leverage that can exceed the capacity of the mount even though the monitor weight may be within the stated range.
- ! The manufacturer accepts no responsibility for incorrect installation.
- ! This product is compatible with AWM Series monitor arm products: AWM-AHX, AWM-LC, AWM-A46 & AWM-A71.

1. Attach VESA head to monitor

1.1 Screw the VESA head onto monitor

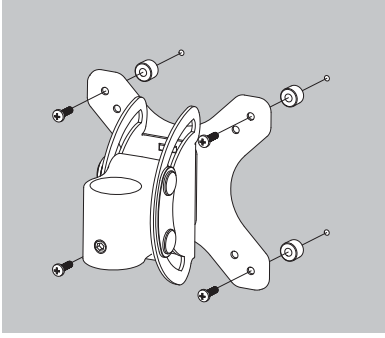

Note: Spacers may be required for curved, recessed or uneven monitor surfaces.

1.2 Ensure suitable screw size is used.

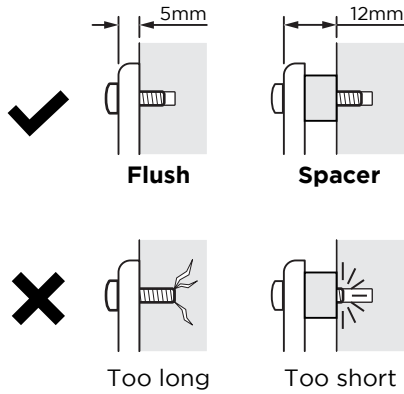

1.3 VESA mounting compatibility

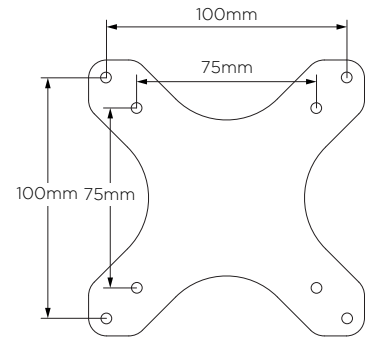

Note: For other sizes, use a suitable adaptor plate

2. Mount monitor onto arm

2.1 Push tilt head onto the shaft at the end of the monitor arm.

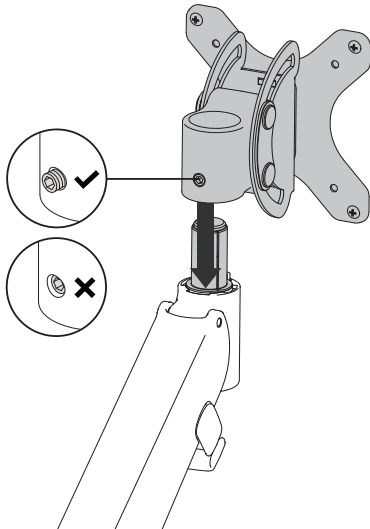

2.2 Ensure tilt head is fully pushed onto shaft.

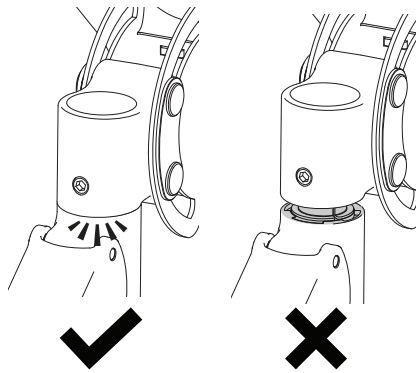

2.3 Tighten the joint screw to secure the tilt head and monitor in place.

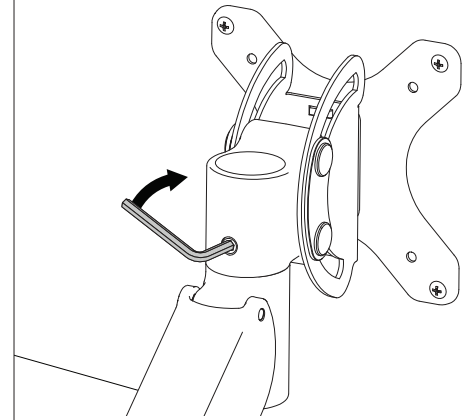

Note: Check the arm rotation is smooth after tightening.

3. Adjust tilt tension

3.1 Use the knob to tighten and loosen the tilt tension to suit your monitor weight.

Note: Always support the monitor whilst adjusting to prevent it from falling forward sharply.

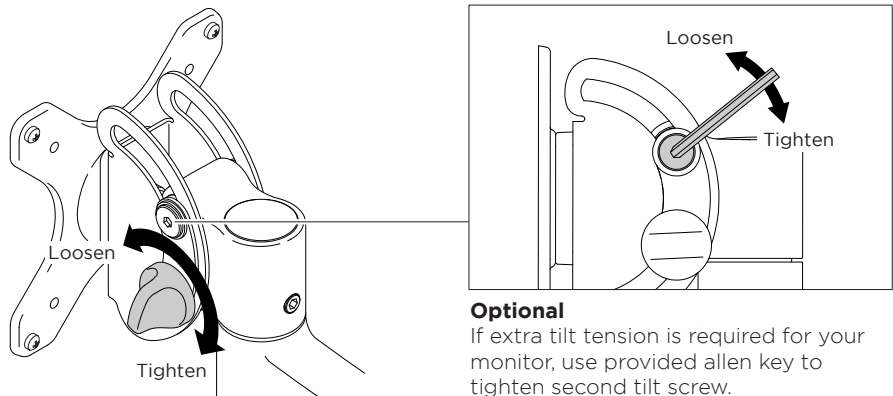

Optional
If extra tilt tension is required for your monitor, use provided allen key to tighten second tilt screw.