

1 x 130 Arm and 2 x 710 Arm on 400 Post with C-Clamp

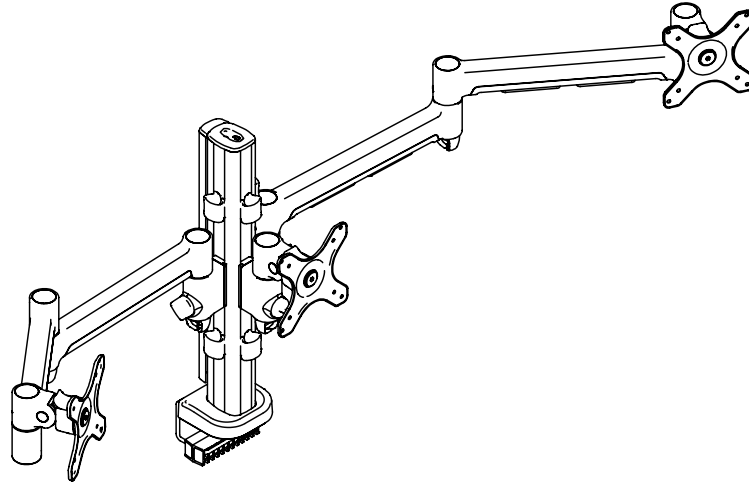

COMPONENT CHECKLIST

RANGE

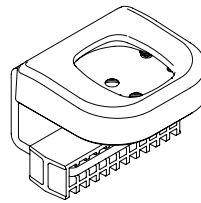
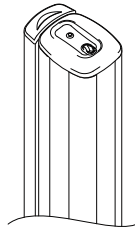
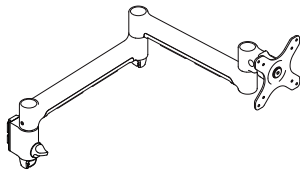
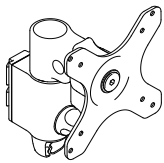

A
AWM-A13
130 Arm
(x1)

B
AWM-A71
710 Arm
(x2)

C
AWM-P40
400 Post
(x1)

D
AWM-FC
C-Clamp
(x1)

CONTENTS

C-Clamp

Page 2
Page 3

AWM-FC

Component Checklist
Clamp Installation

400 Post

Page 6
Page 7

AWM-P40

Component Checklist
Post Installation

130 Arm

Page 8
Page 9
Page 10
Page 11

AWM-130

Component Checklist
Arm Installation
Monitor Installation
Cable Management

460 Arm

Page 12
Page 13
Page 14
Page 15

AWM-460

Component Checklist
Arm Installation
Monitor Installation
Cable Management

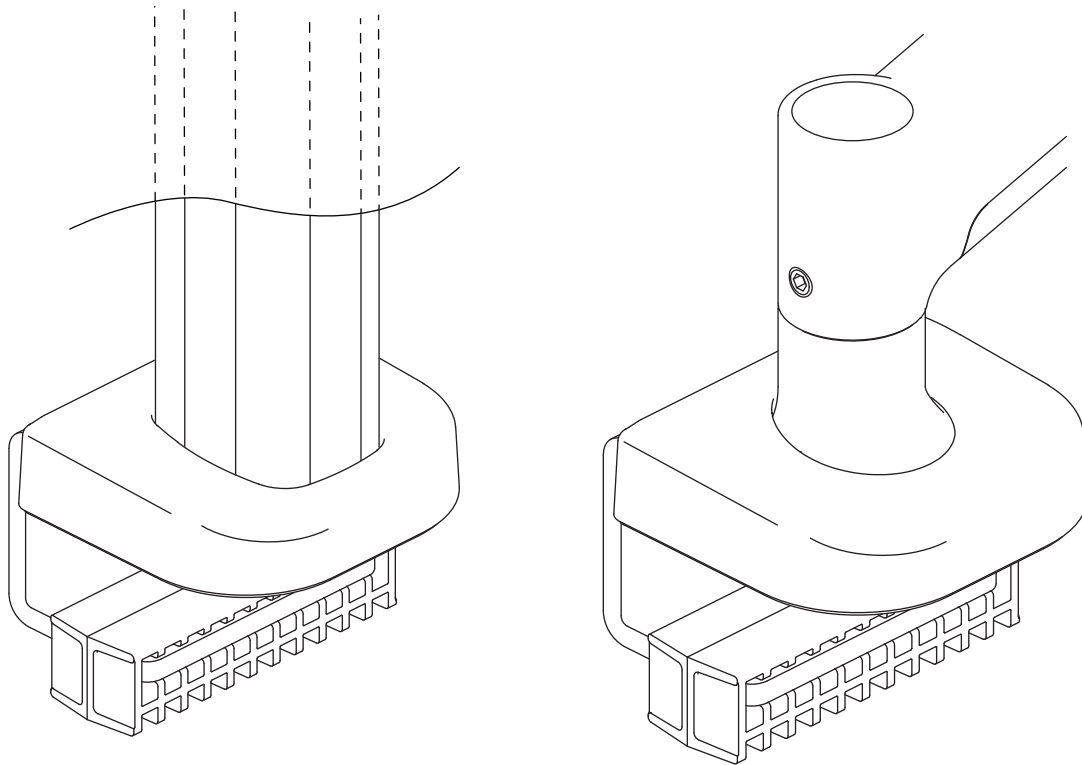

COMPONENT CHECKLIST

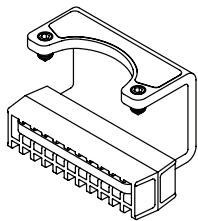

A
C Clamp Bracket
(x1)

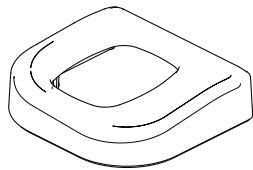

C
Cover for Post
(x1)

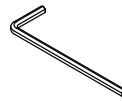

E
4mm Allen key
(x1)

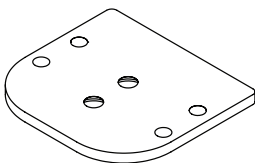

B
C Clamp Plate
(x1)

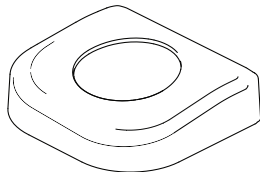

D
Cover for Base
(x1)

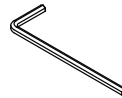

F
5mm Allen key
(x1)

REQUIRED TOOLS

- All tools supplied

IMPORTANT INFORMATION

- ! Please ensure this product is installed as per these installation instructions.
- ! This product is compatible with Atdec modular (AWM) products.
- ! The manufacturer accepts no responsibility for incorrect installation.

1. C Clamp overview

1.1 Default - This is the "out of the box" configuration

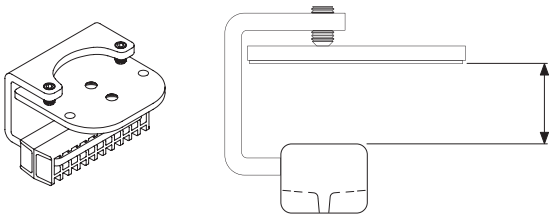

MIN THICKNESS - 25mm (1")
MAX THICKNESS - 33mm (1⁵/₁₆")

1.2 Inverted - The C Clamp can be reconfigured for thicker surfaces

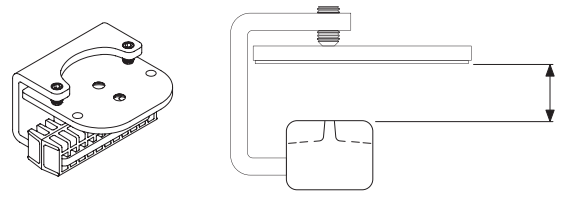

MIN THICKNESS - 18mm (1¹/₁₆")
MAX THICKNESS - 25.8mm (1")

2. Re-configure Clamp

2.1 Slide pad off

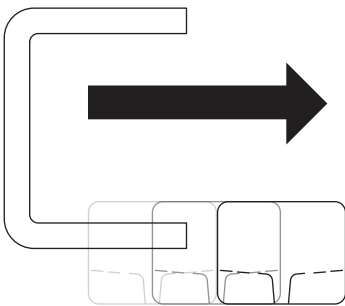

2.3 Invert pad

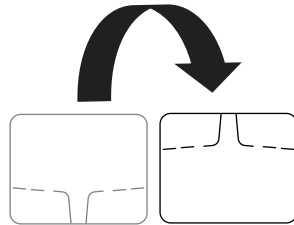

2.3 Slide pad back on

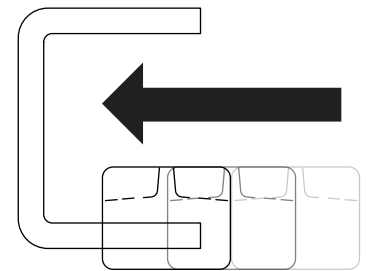

3. Post mount configuration

3.1 Attach plate to post

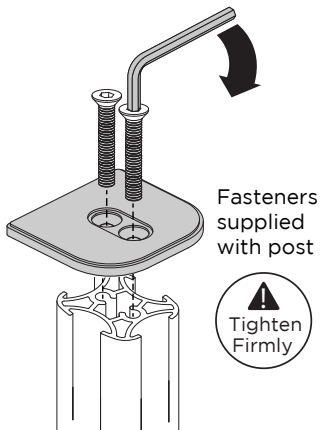

3.2 Place in desired location

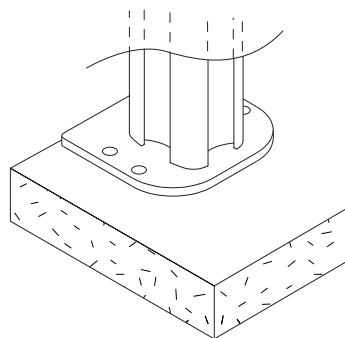

3.3 Slide the C Clamp bracket over the plate and position screw tips in the indents on the base plate

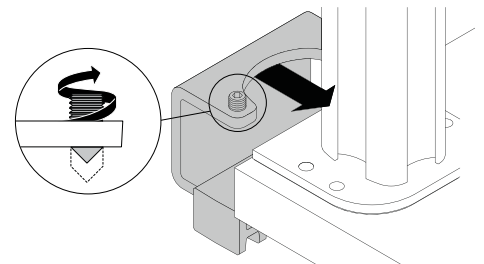

Note: You may need to un-screw the set screws out of the plate using the allen key

3.4 Check the set screws are mounted in position. Also check the desk clamp bracket is positioned tight up against the mounting surface edge

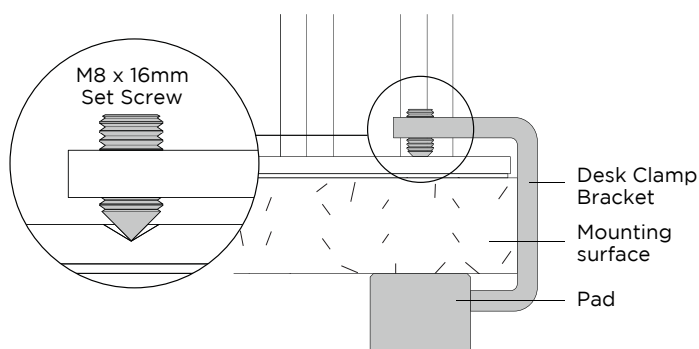

3.5 Tighten the set screws **firmly** and **evenly** on both sides of the desk clamp bracket.

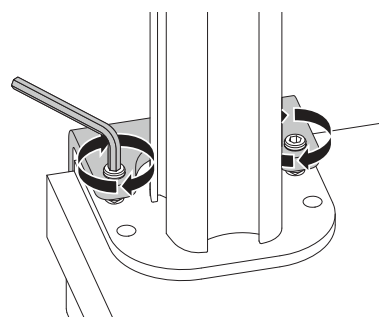

4. Installing the clamp cover to post

4.1 Remove the cable cover by pulling it straight up and out of the post. Remove top cap if already installed

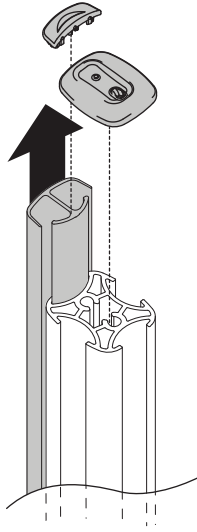

4.2 Locate the C Clamp cover over the post. Guide over the holes in the base plate and gently apply pressure on the cover until it clicks into place

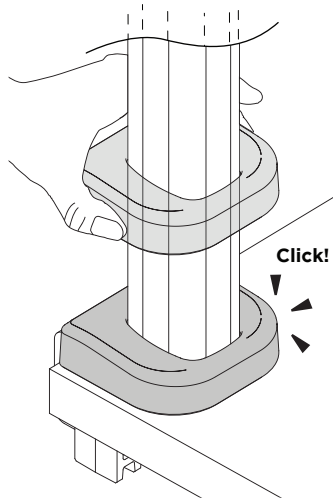

4.3 Re-attach the cable cover by sliding it into the post channel. Fit the pole and cover caps back on.

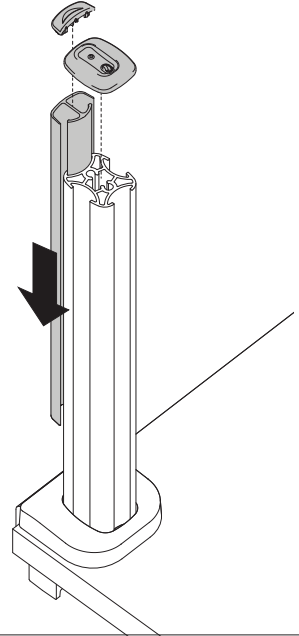

5. Base mount installation

5.1 Attach plate to base

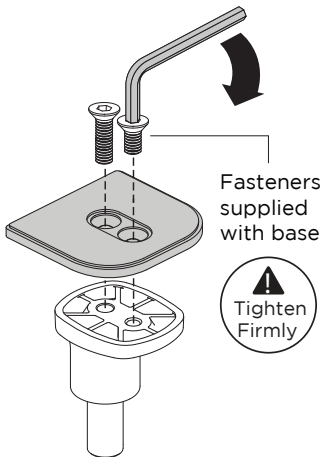

5.2 Place the base and plate in desired location

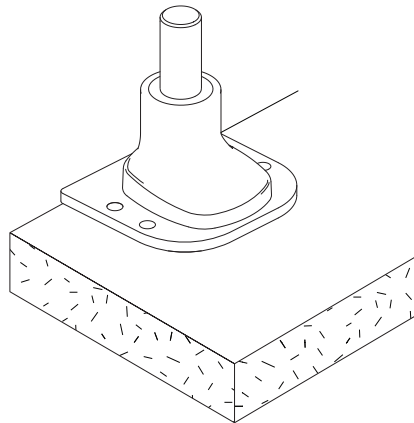

5.3 Slide the bracket onto the base plate and position screw tips in the indents on the base plate

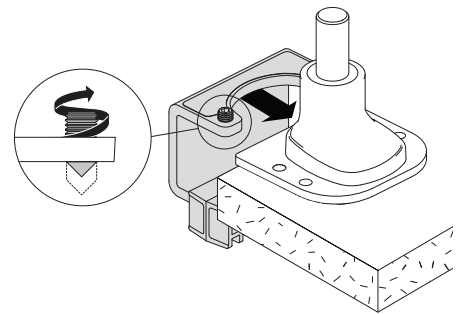

Note: You may need to un-screw the set screws out of the plate using the allen key

5.4 Check the set screws are mounted in position. Also check the desk clamp bracket is positioned tight up against the mounting surface edge

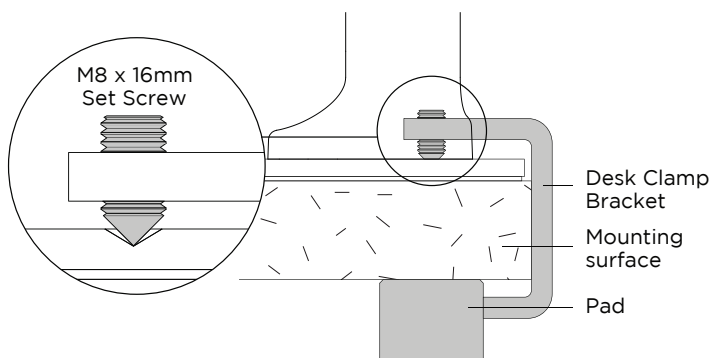

5.5 Tighten the set screws **firmly** and **evenly** on both sides of the desk clamp bracket

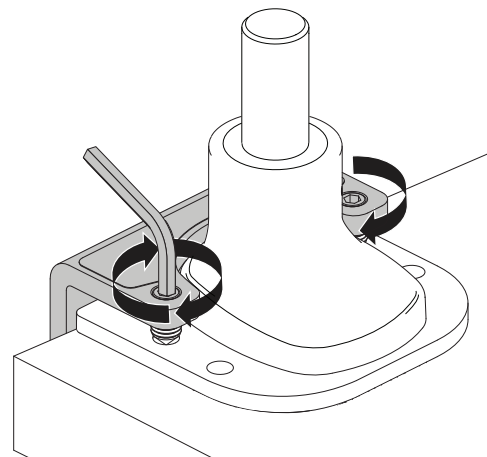

6. Installing the clamp cover to base

6.1 Locate the Cover for Base over the base. Guide over the holes in the base plate and gently apply pressure on the cover until it clicks into place.

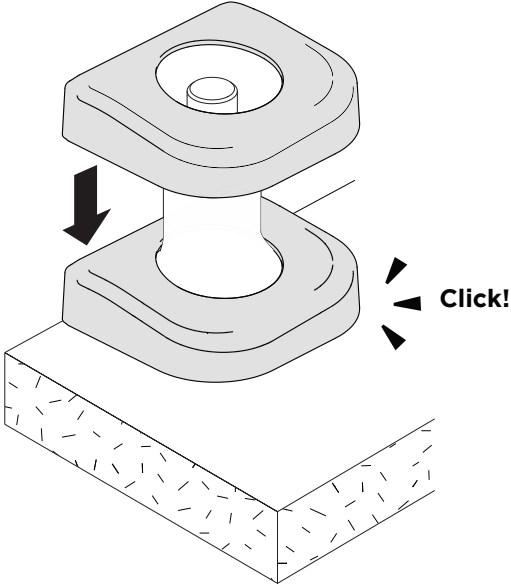

6.2 Installation Complete

To continue with installation of your monitor arm, refer to your monitor arm's installation guide.

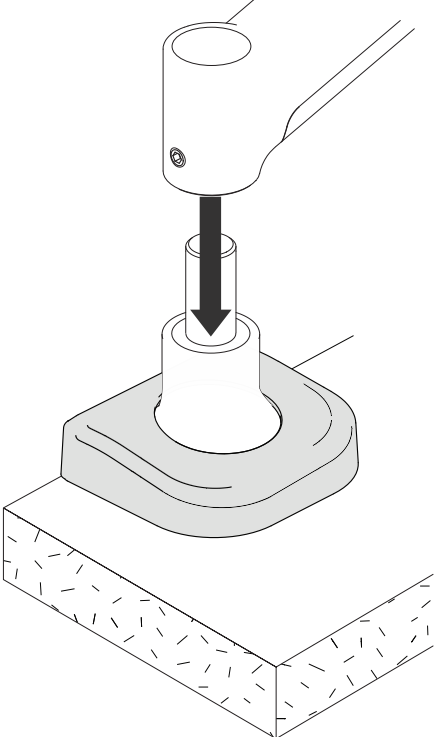

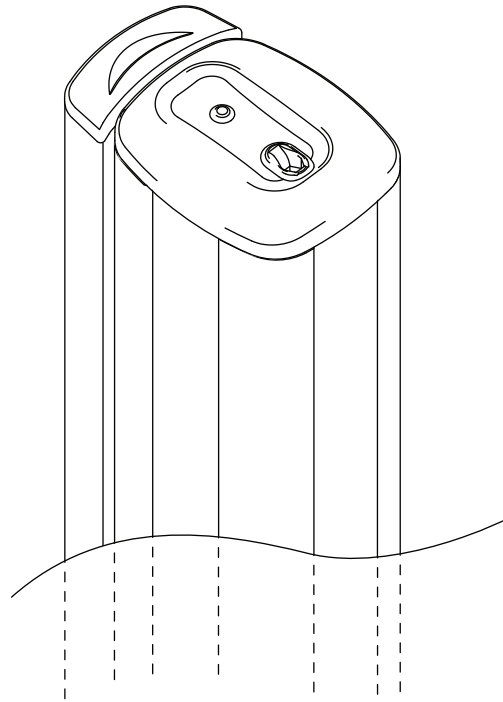

COMPONENT CHECKLIST

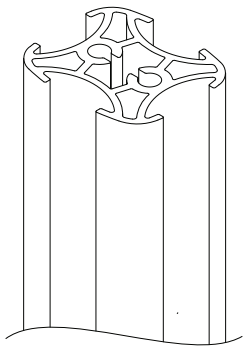

A
Post
(x1)

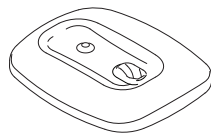

B
Post Cap
(x1)



C
Screw M8
(x2)



D
Cable Cover Cap
(x1)
(not supplied
with all posts)

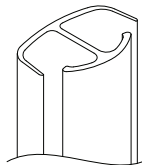

E
Cable Cover
(x1)
(not supplied
with all posts)



F
Cable clips
(not supplied
with all posts)

Desk 

REQUIRED TOOLS

- All tools provided

IMPORTANT INFORMATION

- ! Please ensure this product is installed as per these installation instructions.
- ! This product is compatible with Atdec AWM Series products.
- ! The manufacturer accepts no responsibility for incorrect installation.

1. Attach Post to fixing (fixing sold separately)

1.1 Follow the installation guide provided with your fixing to attach it to the post and fit it to the worksurface.

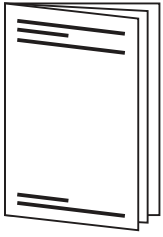

AWM Fixing options

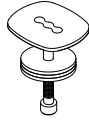

Bolt Through Kit
AWM-FB

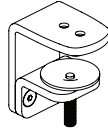

F Clamp
AWM-FF

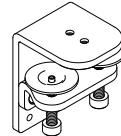

Heavy Duty F Clamp
AWM-FH

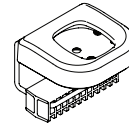

C Clamp
AWM-FC

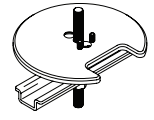

Grommet Clamp
AC-GC

2. Check post placement & arm positions

2.1 Do not mount a monitor arm on the rear channel of a post when the post is fixed to the desk using an F Clamp, Heavy Duty F Clamp, or C Clamp.

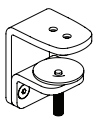

F Clamp
AWM-FF

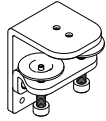

Heavy Duty F Clamp
AWM-FH

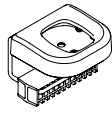

C Clamp
AWM-FC

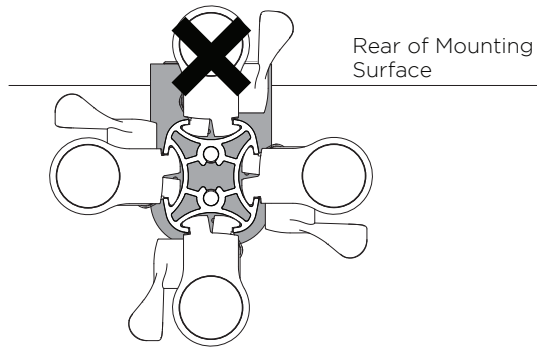

Rear of Mounting Surface

3. Cable cover position and post cap

3.1 To reposition the cable cover, pull it straight up and out of the post and insert it into any of the available channels

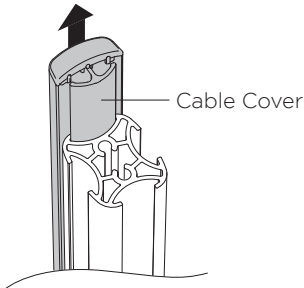

Cable Cover

Note: The cable cover shown does not come with all posts

3.2 Optional cable cover positions

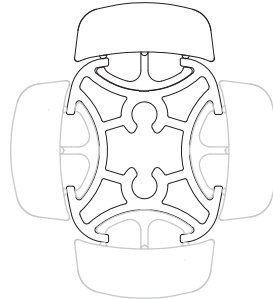

3.3 Fit post cap onto the top of the post

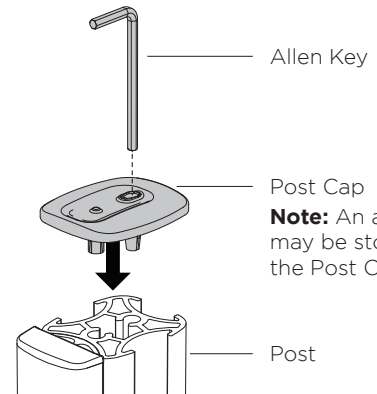

Allen Key

Post Cap

Note: An allen key may be stored in the Post Cap.

Post

4. Cable clips and cover

4.1 Push the cable down into the cable clip.

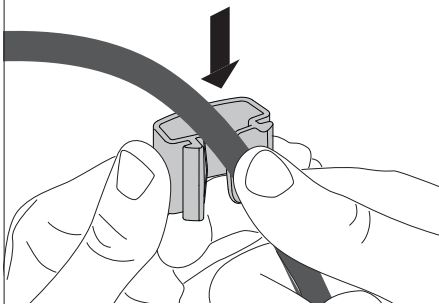

Note: Cable clips do not come with all posts. Additional clips sold separately.

4.2 Insert one side of the cable clip into the channel on the post assembly, then push in the other side.

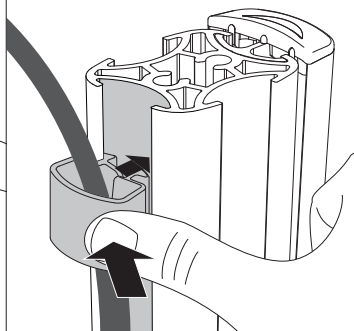

4.3 Loop cable and insert into cable cover.

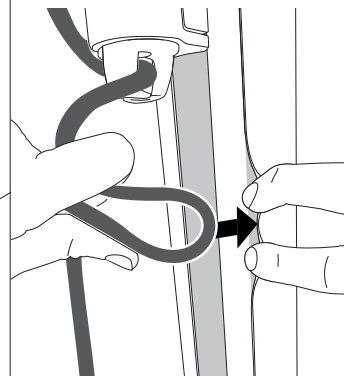

4.4 Feed remaining cable into the cover.

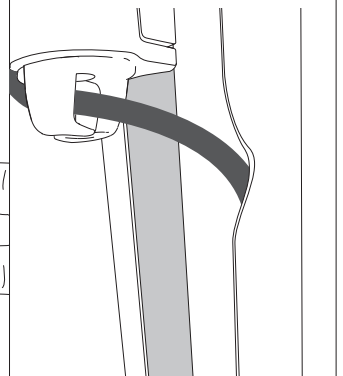

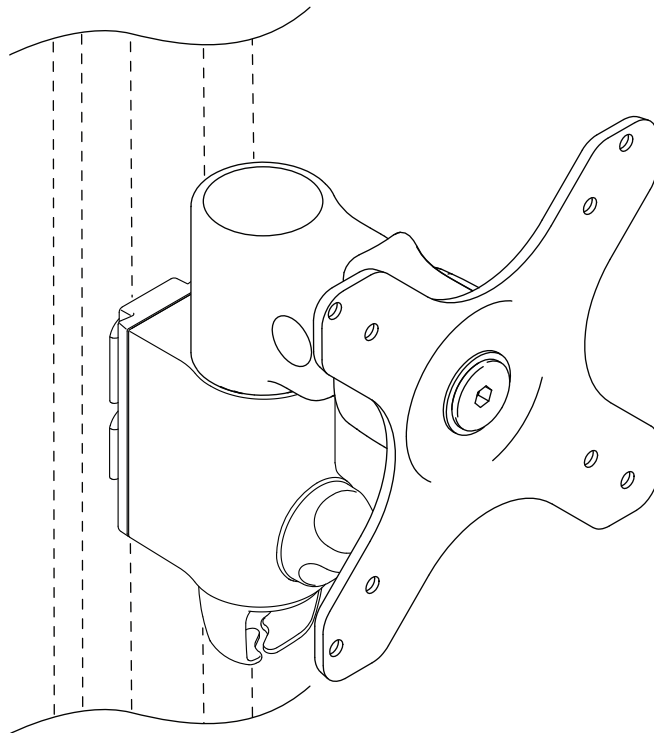

COMPONENT CHECKLIST

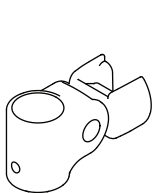

A
Monitor Arm
(x1)

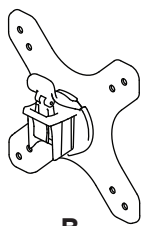

B
VESA Head
(x1)

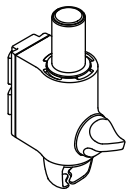

C
Post Clamp
(x1)

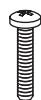

D
Screw
M4x25mm
(x4)



E
Screw
M4x16mm
(x4)



F
Screw
M4x12mm
(x4)



G
Spacer
(x4)



H
Security
screw
(x1)

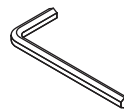

I
4mm
allen key
(x4)

Desk 

REQUIRED TOOLS

- Phillips Head Screwdriver

WEIGHT RANGE

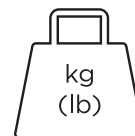

kg
(lb) 0 - 12kg
(0 - 26.5lbs)

IMPORTANT INFORMATION

- ! Please ensure this product is installed as per these installation instructions.
- ! The manufacturer accepts no responsibility for incorrect installation.
- ! This product is compatible with Atdec AWM Series products.

1. Fix clamp to Post or Wall Channel

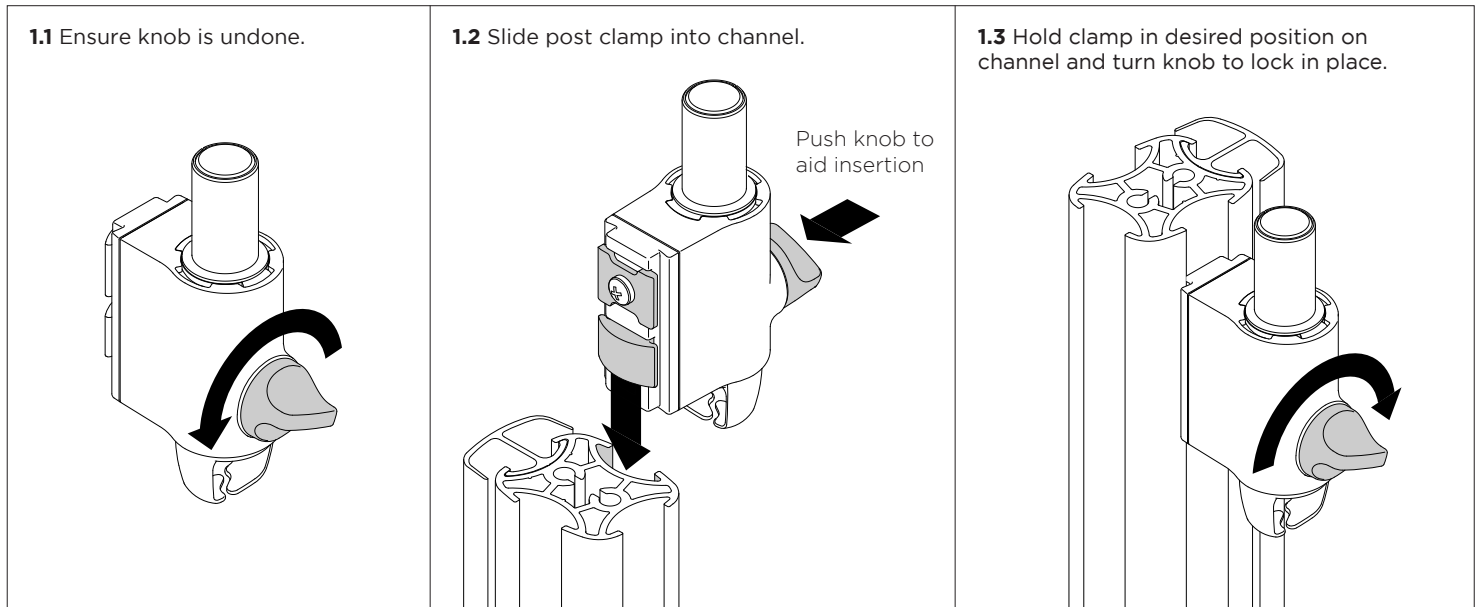

2. Set arm rotation to 180° (optional)

Note rotation is set to 360° by default.

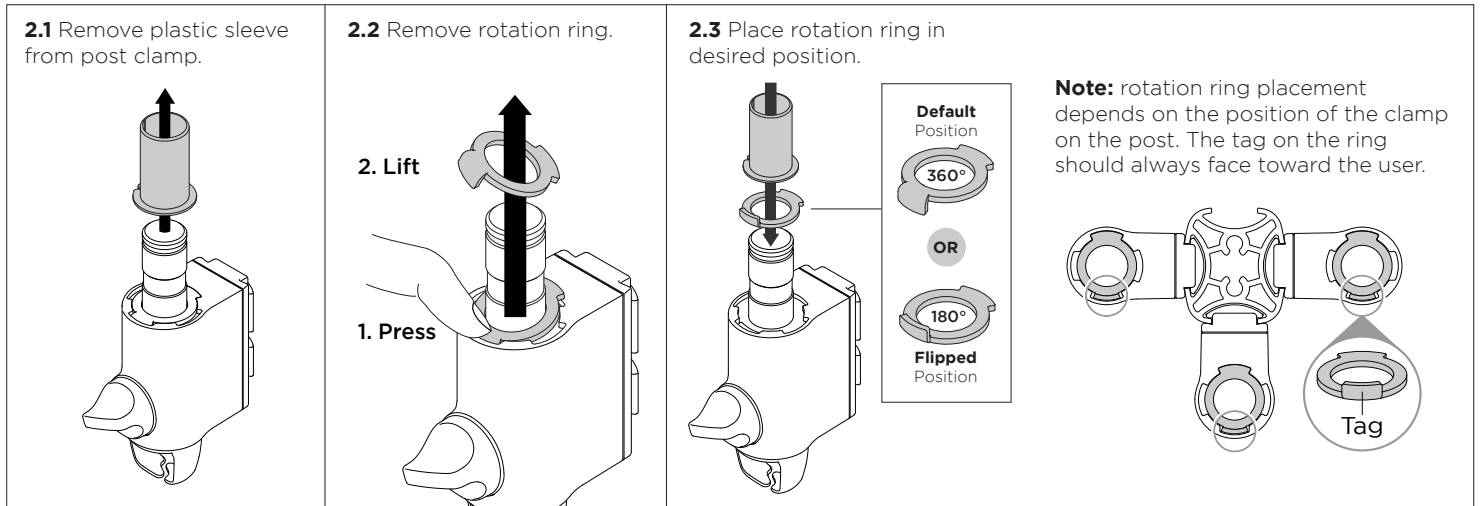

3. Fit arm onto post clamp

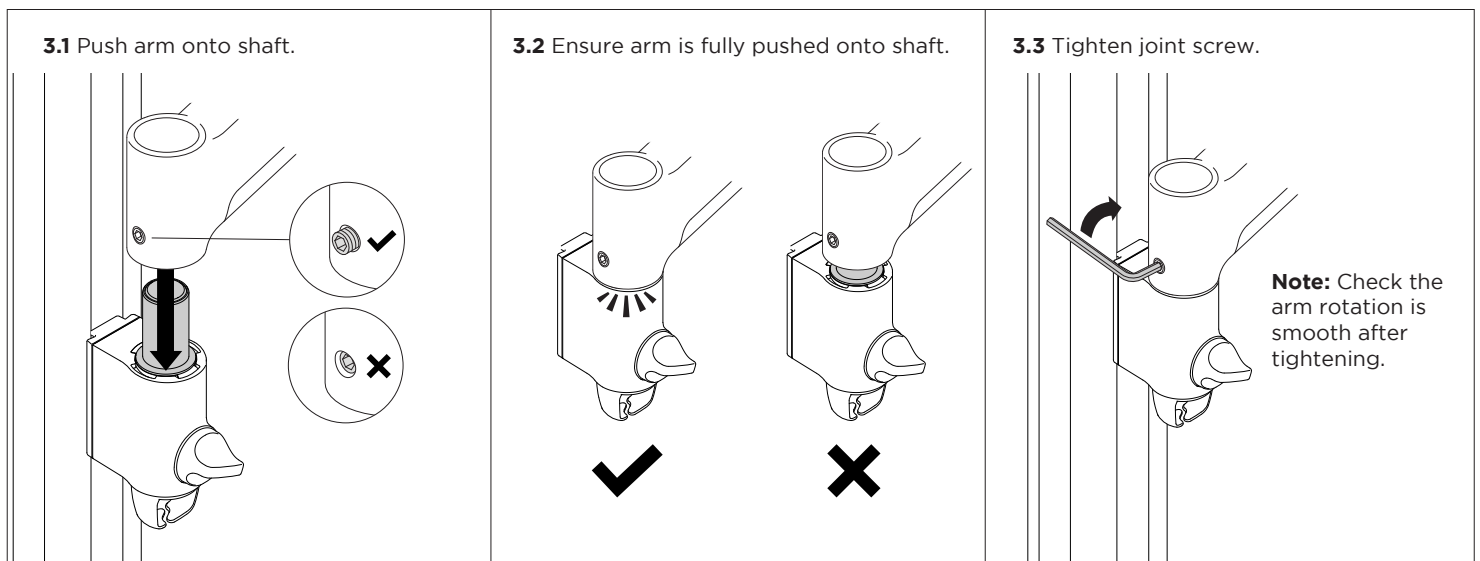

4. Attach VESA head to monitor

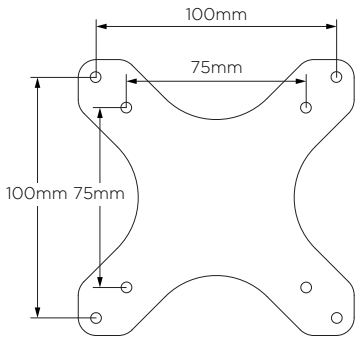
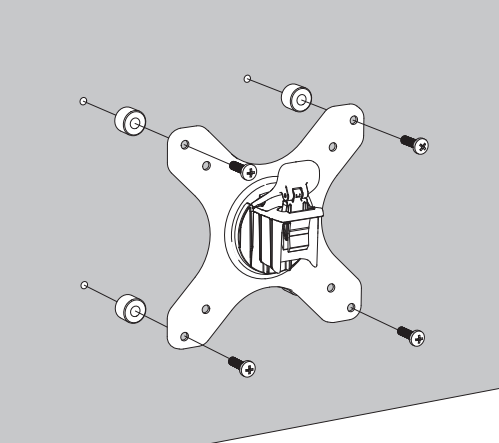
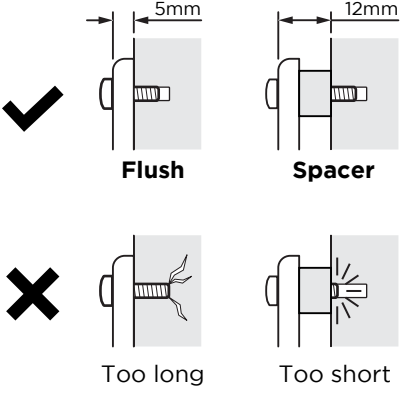
<p>4.1 VESA mounting compatibility</p>  <p>Note: For other sizes, use a suitable adaptor plate (sold separately).</p>	<p>4.2 Screw the VESA head onto monitor</p>  <p>Note: spacers may be required for curved, recessed or uneven monitor surfaces.</p>	<p>4.3 Ensure the correct screw length is used to attach the monitor.</p>  <p>✓ Flush (5mm) Spacer (12mm)</p> <p>✗ Too long Too short</p>
--	--	---

5. Mount monitor

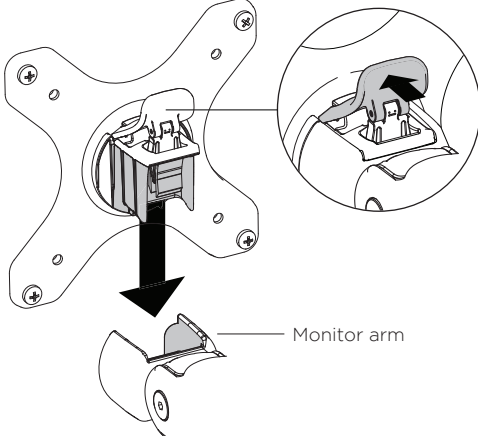
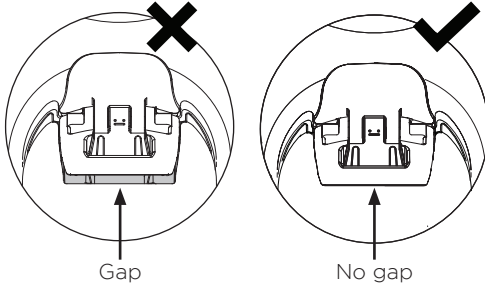
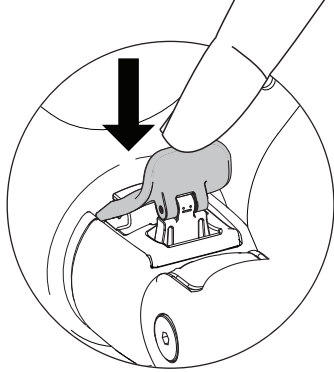
<p>5.1 Insert VESA head into the monitor arm</p>  <p>Monitor arm</p>	<p>5.2 Ensure that the VESA head sits flush within the monitor arm. There should be no gap</p>  <p>Gap No gap</p>	<p>5.3 Push the lever down to secure it to the arm assembly</p> 
--	--	---

6. Adjust tilt tension & Install security screw

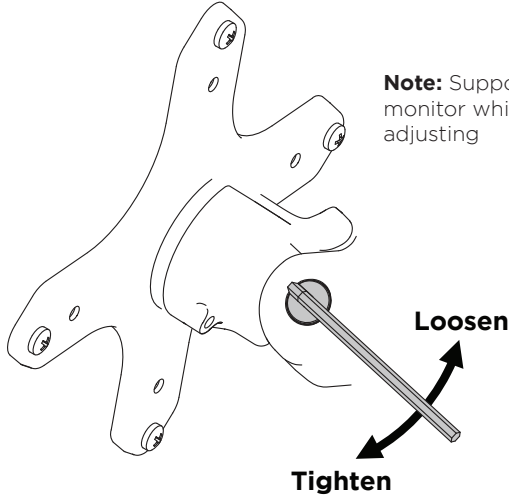
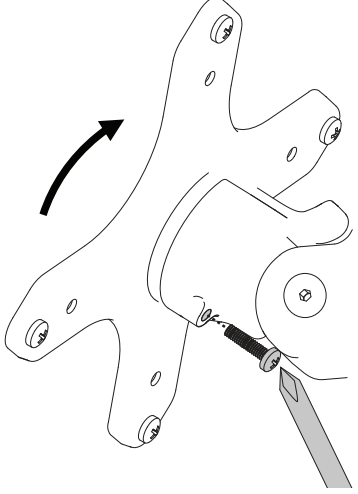
<p>6.1 Use the allen key to adjust the tilt tension until the monitor holds in a vertical position at the end of the arm.</p>  <p>Note: Support monitor while adjusting</p> <p>Loosen</p> <p>Tighten</p>	<p>6.2 OPTIONAL security screw To install the optional security screw tilt the head upwards</p> 
---	---

6. Monitor arm cable management

6.1 Plug cables into the monitor and route the cables down the arm using the cable hooks and clips.

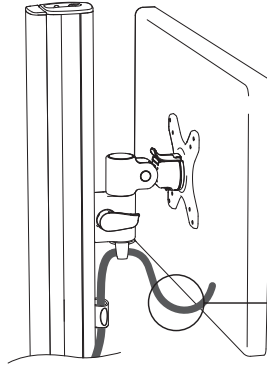

Important:

Ensure enough cable slack is given to allow for movement of the monitor

7. Post cable management

7.1 Push the cable down into the cable clip

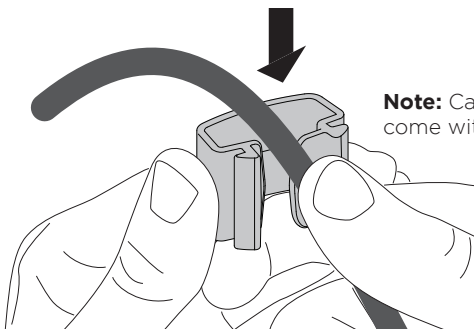

Note: Cable clips do not come with all posts

7.2 Push cable clip into post channel

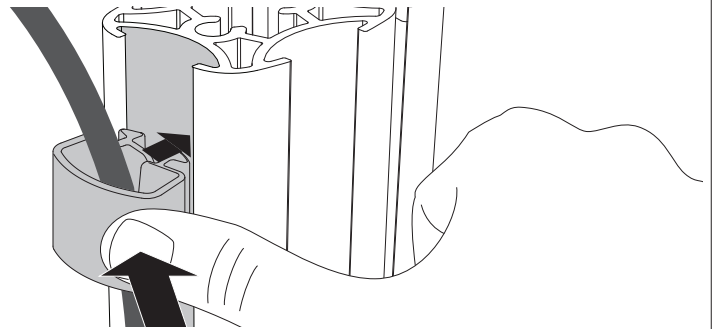

7.3 Recommended post cable cover position for double or triple arm set-ups

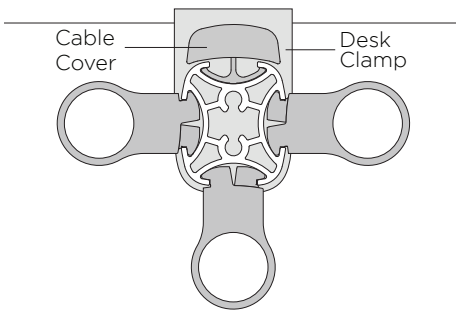

7.4 To reposition the cable cover, pull it straight up and out of the post and insert it into any of the available channels

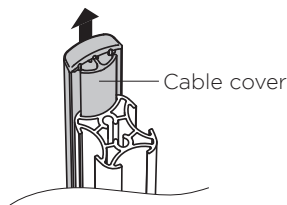

Note: The cable cover shown does not come with all posts

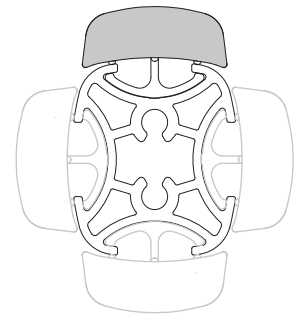

Alternative cable cover positions

7.5 Loop cable and insert into cable cover

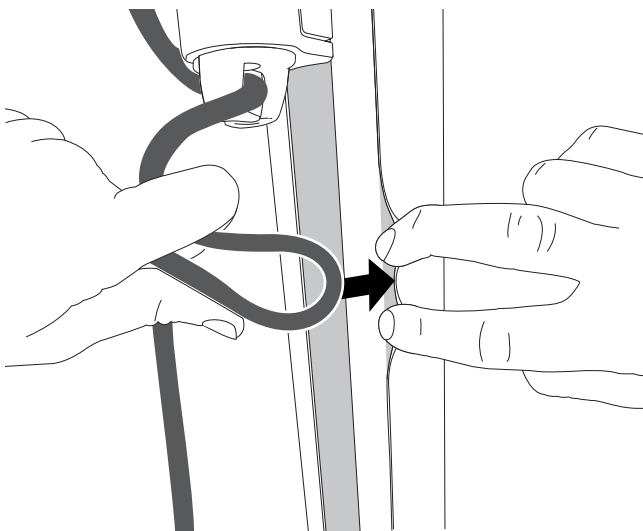

7.6 Feed remaining cable into cover

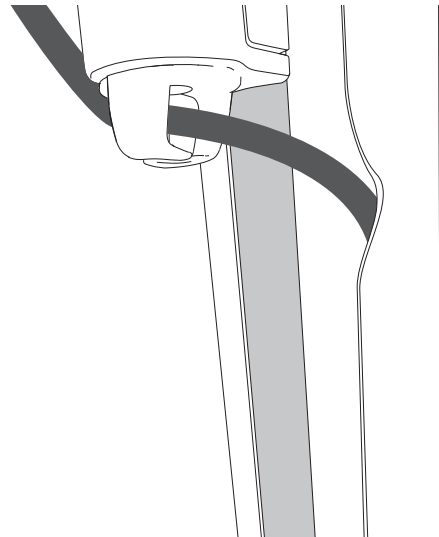

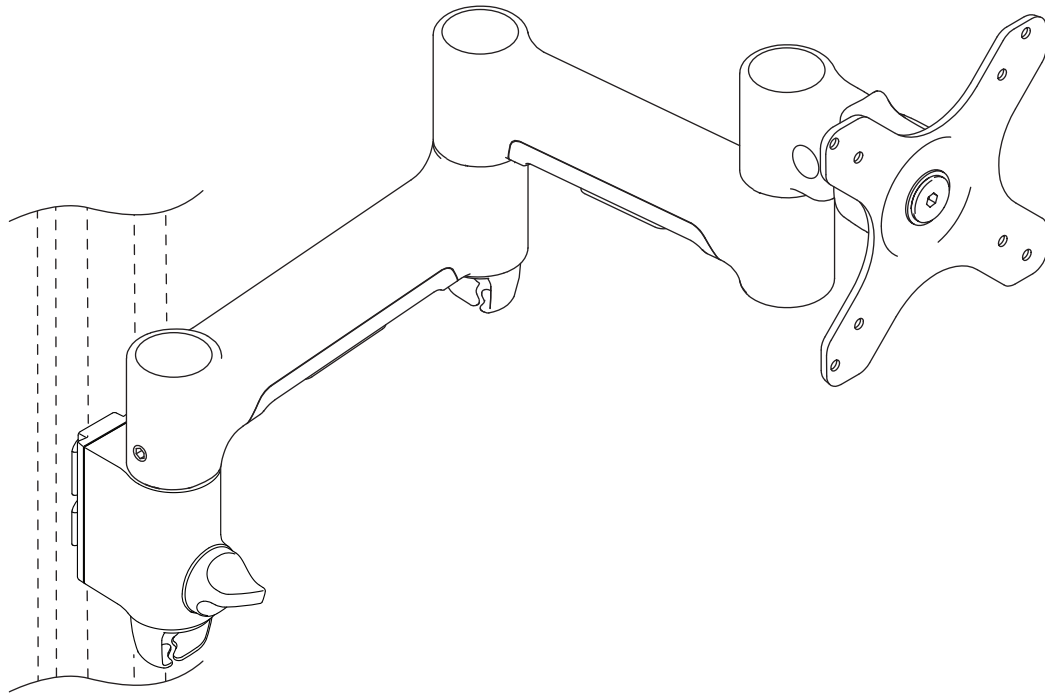

COMPONENT CHECKLIST

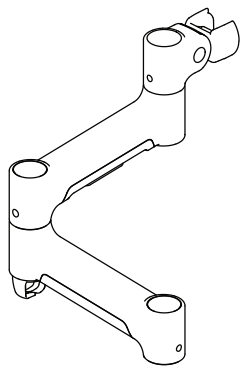

A
Monitor Arm
(x1)

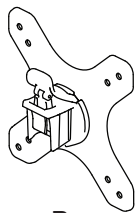

B
VESA Head
(x1)

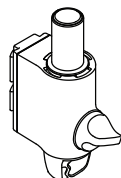

C
Post Clamp
(x1)



D
Screw
M4x25mm
(x4)



E
Screw
M4x16mm
(x4)



F
Screw
M4x12mm
(x4)



G
Spacer
(x4)



H
Security
screw
(x1)

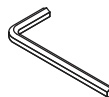

I
4mm
allen key
(x1)

Desk 

REQUIRED TOOLS

- Phillips Head Screwdriver

WEIGHT RANGE

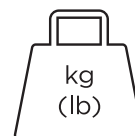

kg
(lb)

0 - 12kg
(0 - 26.5lbs)

IMPORTANT INFORMATION

- ! Please ensure this product is installed as per these installation instructions.
- ! The manufacturer accepts no responsibility for incorrect installation.
- ! This product is compatible with Atdec AWM Series products.

1. Fix clamp to Post or Wall Channel

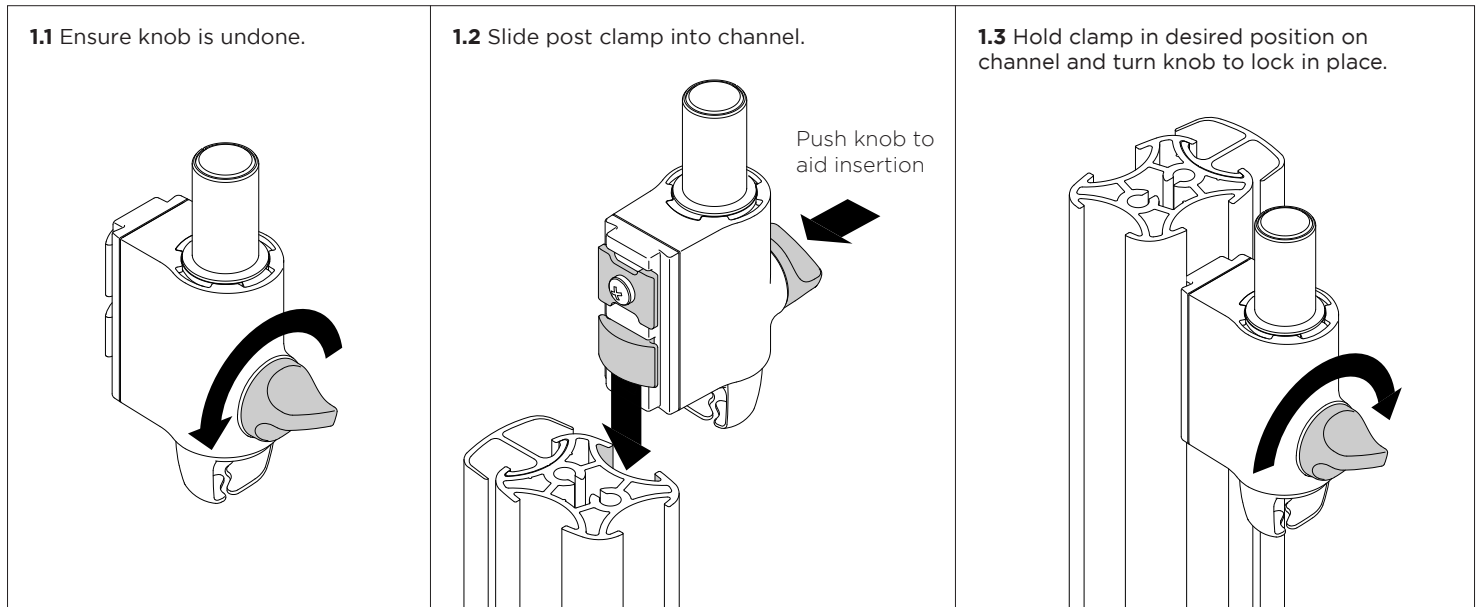

2. Set arm rotation to 180° (optional)

Note rotation is set to 360° by default.

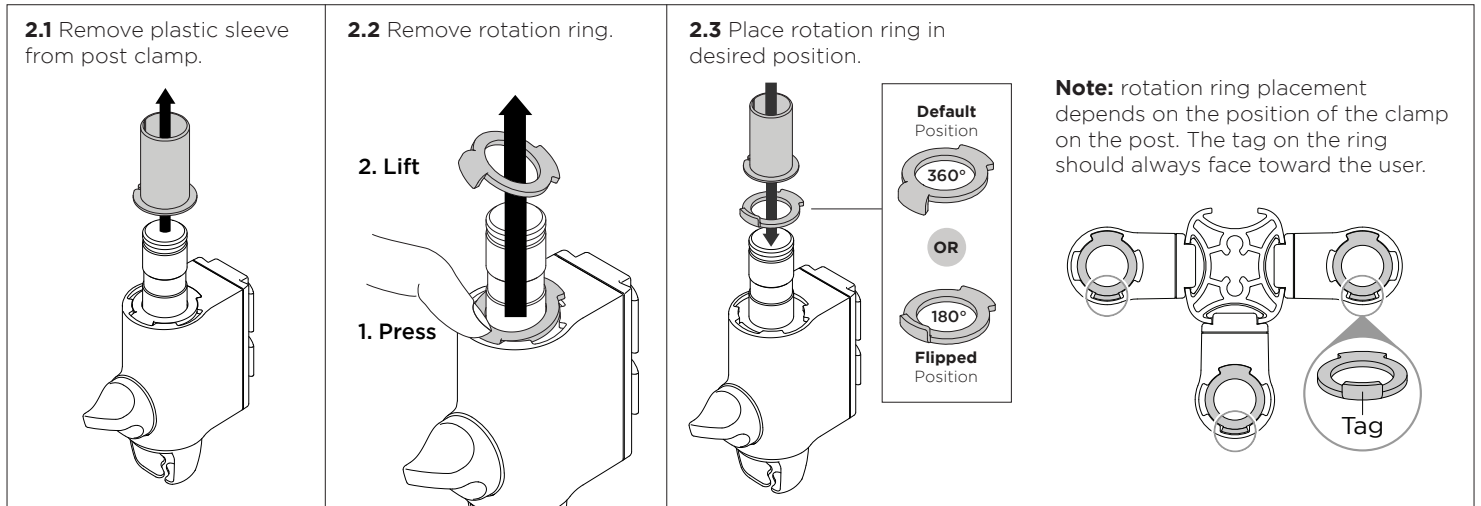

3. Fit arm onto post clamp

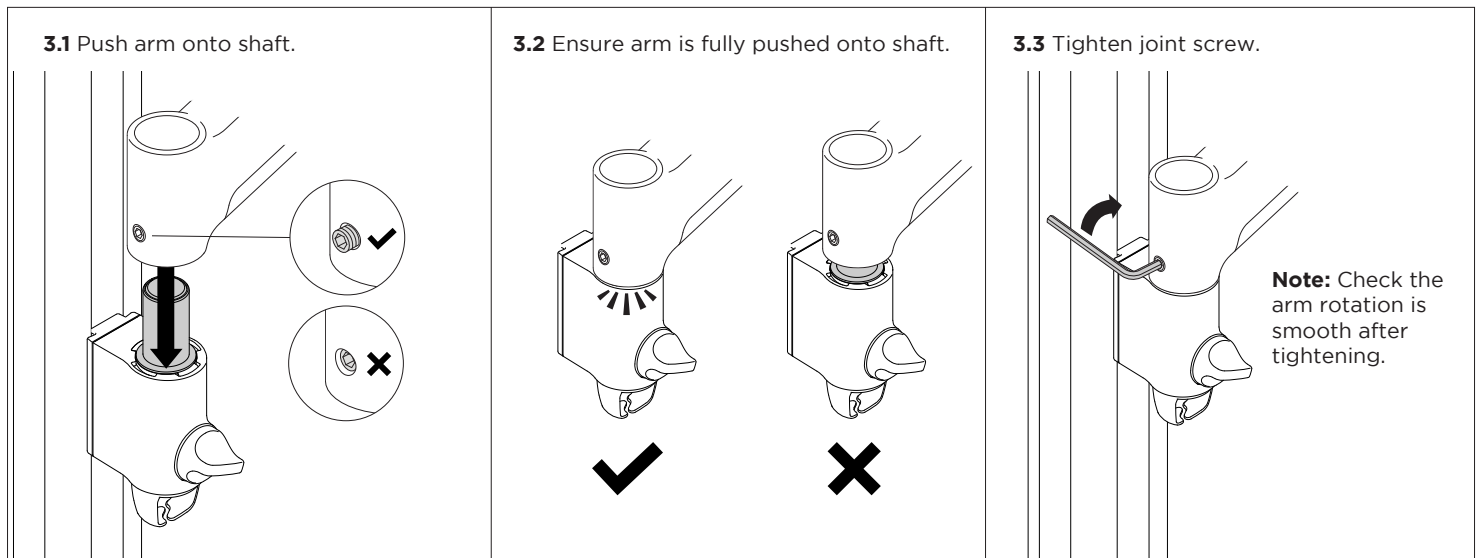

4. Attach VESA head to monitor

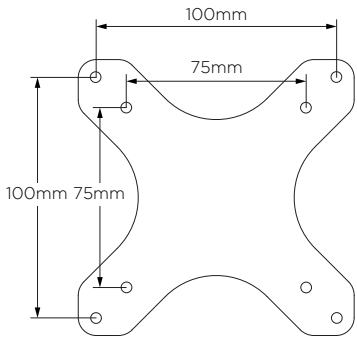
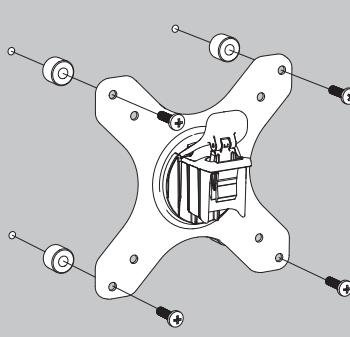
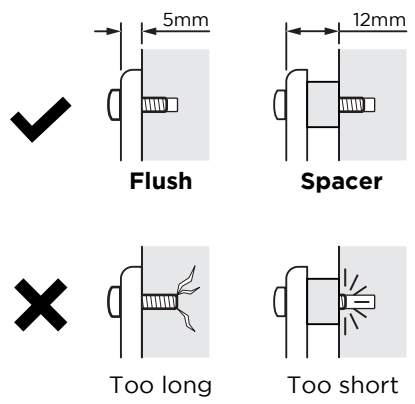
<p>4.1 VESA mounting compatibility</p>  <p>Note: For other sizes, use a suitable adaptor plate (sold separately).</p>	<p>4.2 Screw the VESA head onto monitor</p>  <p>Note spacers may be required for curved, recessed or uneven monitor surfaces.</p>	<p>4.3 Ensure the correct screw length is used to attach the monitor.</p>  <p>✓ Flush Spacer</p> <p>✗ Too long Too short</p>
--	--	--

5. Mount monitor

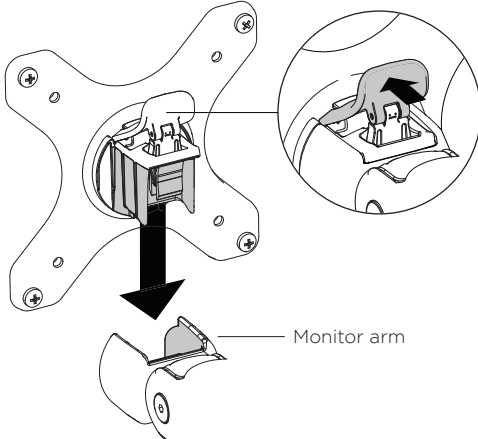
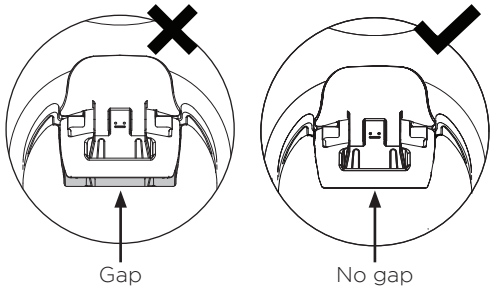
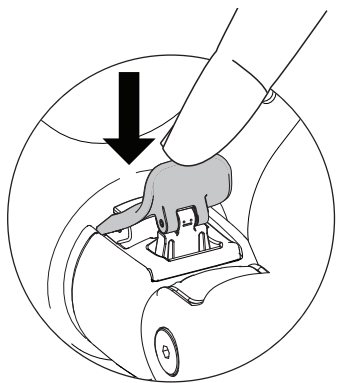
<p>5.1 Insert VESA head into the monitor arm</p>  <p>Monitor arm</p>	<p>5.2 Ensure that the VESA head sits flush within the monitor arm. There should be no gap</p>  <p>Gap No gap</p>	<p>5.3 Push the lever down to secure it to the arm assembly</p> 
--	--	---

6. Adjust tilt tension & Install security screw

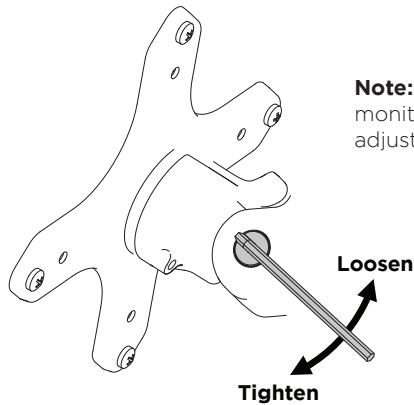
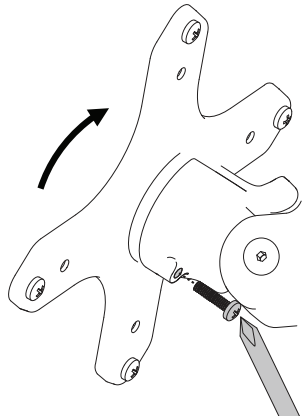
<p>6.1 Use the allen key to adjust the tilt tension until the monitor holds in a vertical position at the end of the arm.</p>  <p>Note: Support monitor while adjusting.</p> <p>Loosen</p> <p>Tighten</p>	<p>6.2 OPTIONAL security screw To install the optional security screw tilt the head upwards</p> 
--	---

6. Monitor arm cable management

6.1 Plug cables into the monitor and route the cables down the arm using the cable hooks and clips

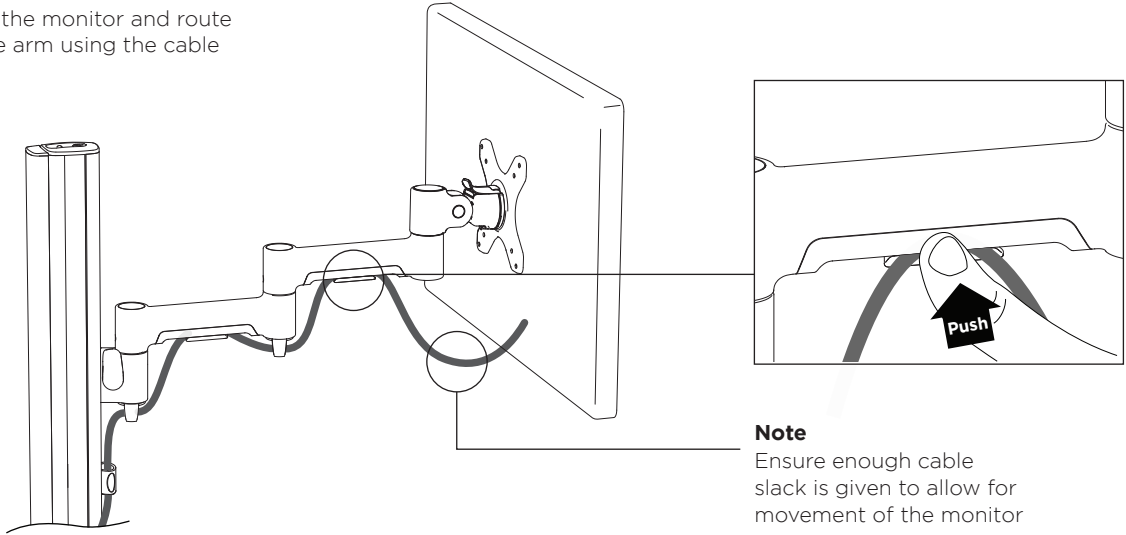

7. Post cable management

7.1 Push the cable down into the cable clip

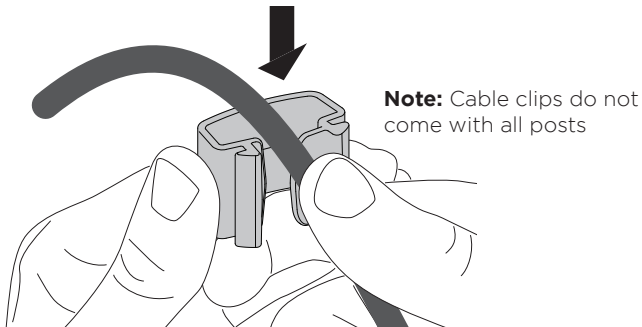

7.2 Push cable clip into post channel

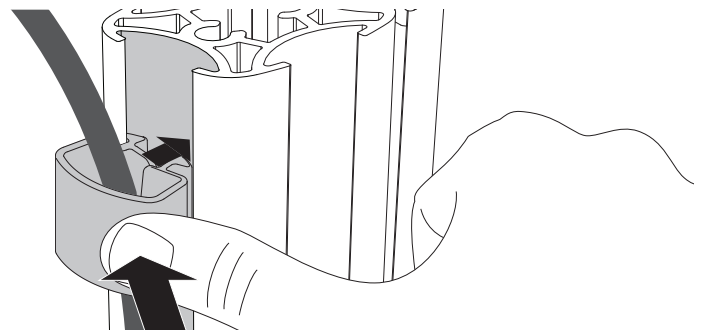

7.3 Recommended post cable cover position for double or triple arm set-ups

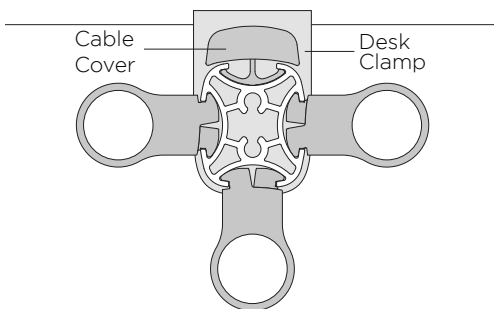

7.4 To reposition the cable cover, pull it straight up and out of the post and insert it into any of the available channels

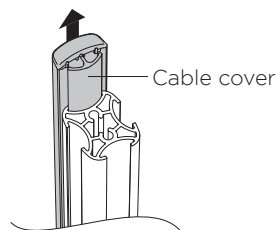

Note: The cable cover shown does not come with all posts

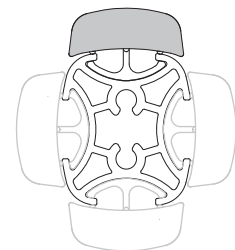

Alternative cable cover positions

7.5 Loop cable and insert into cable cover

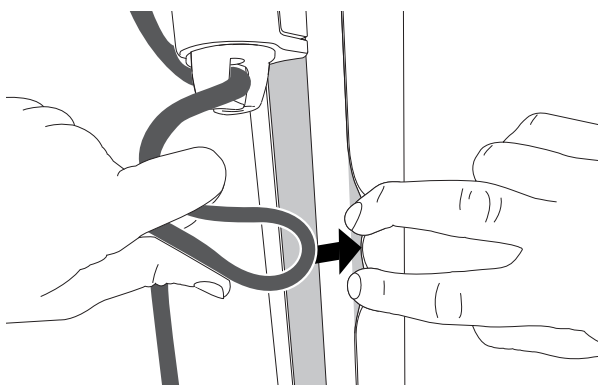

7.6 Feed remaining cable into cover

