

Triple Monitor Mount on 400 Post

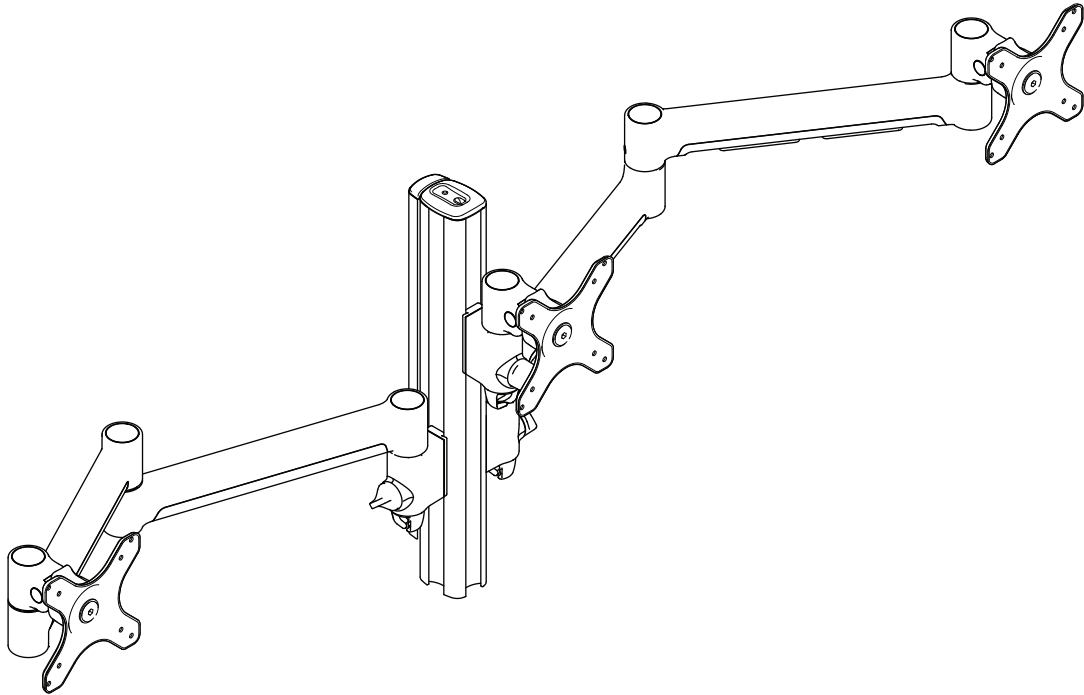

FEATURES

- Supports three monitors up to 24". Larger monitors may be compatible, refer to Monitor Size (page 2).
- Larger screens compatible when upgraded to sliders. Refer to AWM-HS Technical Specification for details.
- Monitor quick release mechanism.
- Integrated, optional 180° rotation limiter to prevent interference with desk mounted panels and dividers.
- Cable management with generous capacity guides cables discreetly down the arms and post to the work surface.

Monitor weight range

A71 0 - 9kg (0 - 20lb)*

A13 0 - 12kg (0 - 25lb)*

Vertical Adjustment 318mm (12.52")

Tilt angle +45° / -25°

Monitor rotation 360°

VESA mounting 75x75 | 100x100

*Monitor weight should be within the weight range of all modular elements that make up the complete monitor mounting solution.

*Curved monitors, deep devices (such as all-in-one PCs) and offset VESA locations exert additional leverage that can exceed the capacity of the mount even though the monitor weight may be within the stated range. Please contact Atdec if you would like further information.

WARRANTY

10 years limited

MONITOR SIZE

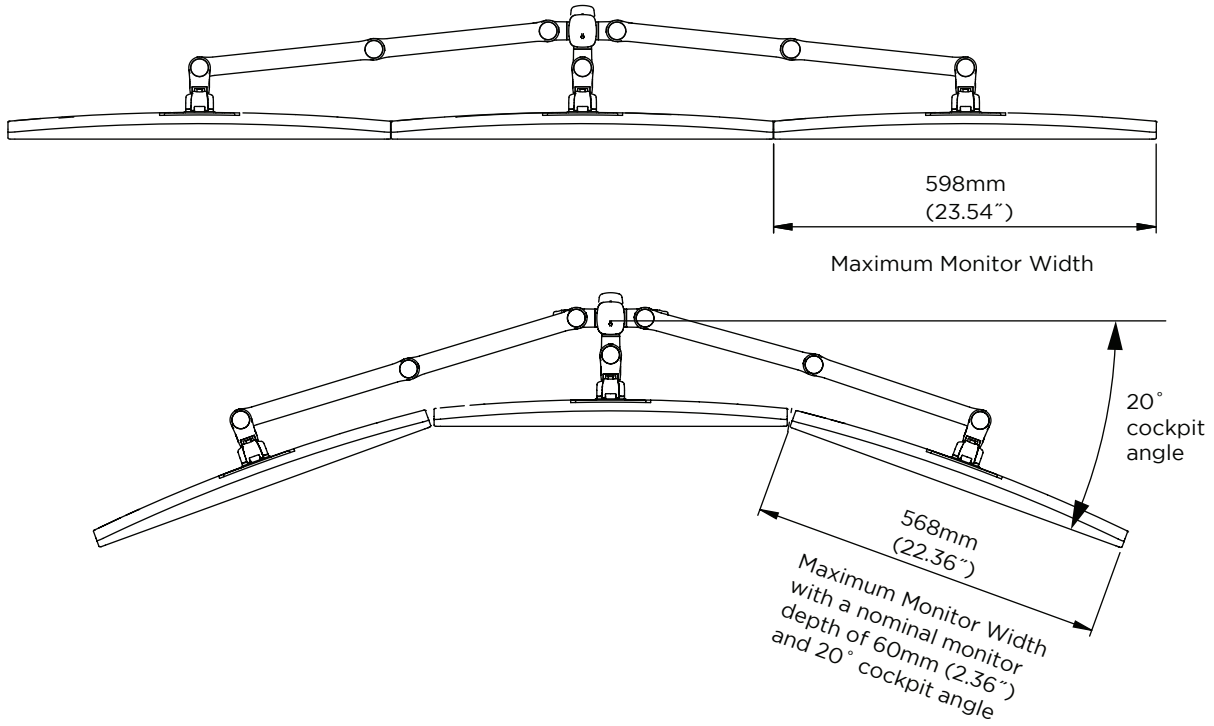

MOVEMENT - 710 ARM

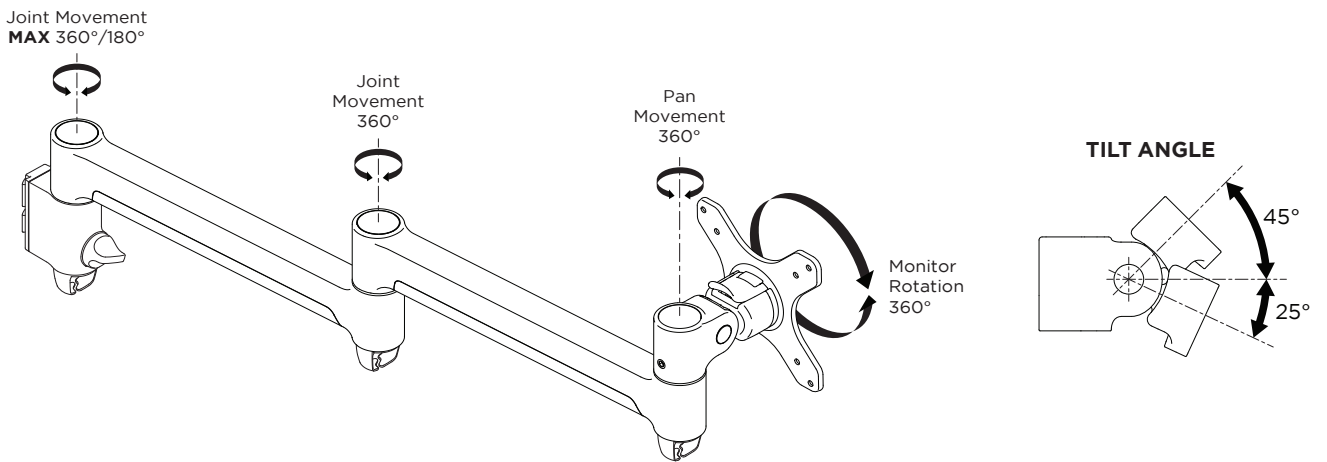

DIMENSIONS - 710 ARM ON POST

Side Attachment

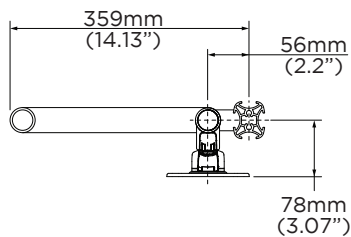

Front Attachment

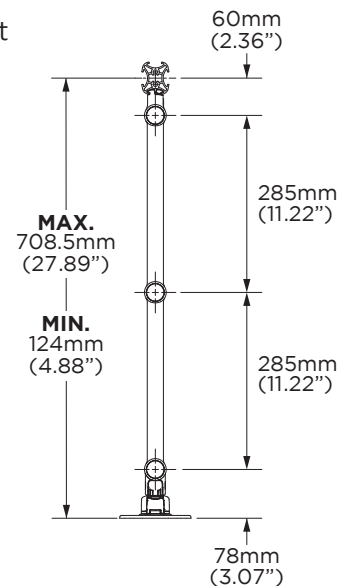

DIMENSIONS - 710 ARM ON 400 POST

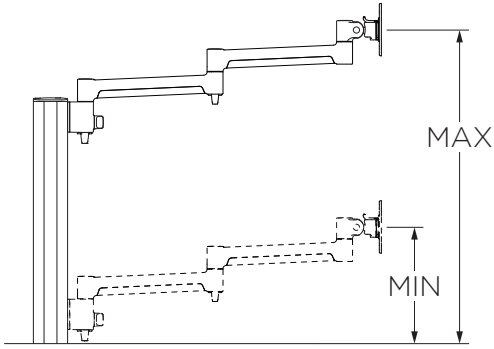

HEIGHT ON 400 POST *C CLAMP INCREASES MINIMUM HEIGHT ON POST BY 26MM (1")	MIN	MAX	RANGE
	230mm* (9.06")	548mm* (21.57")	318mm* (12.52")

MOVEMENT - 130 ARM

Pan Movement
MAX 360°/180°

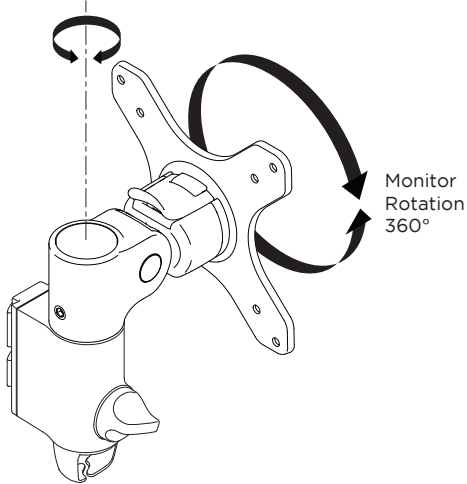

TILT ANGLE

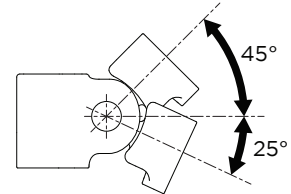

DIMENSIONS - 130 ARM ON POST

Side Attachment

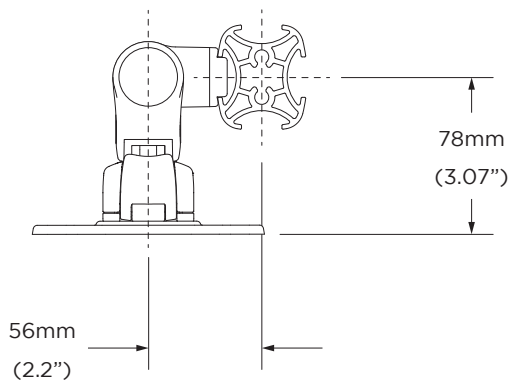

Front Attachment

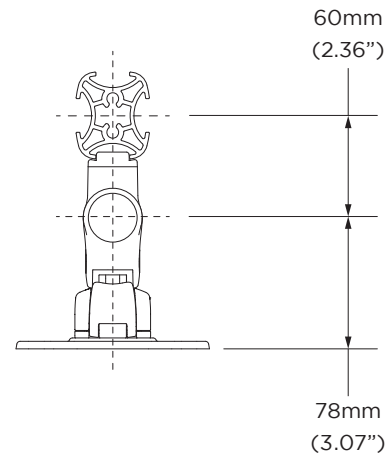

DIMENSIONS - 130 ARM ON 400 POST

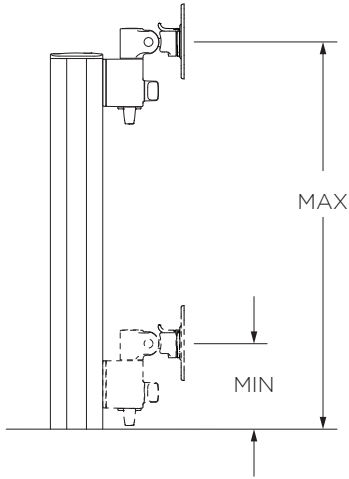

HEIGHT ON 400 POST *C CLAMP INCREASES MINIMUM HEIGHT ON POST BY 26MM (1")	MIN	MAX	RANGE
	110mm* (4.33")	428mm* (16.85")	318mm* (12.52")

DIMENSIONS - VESA HEAD

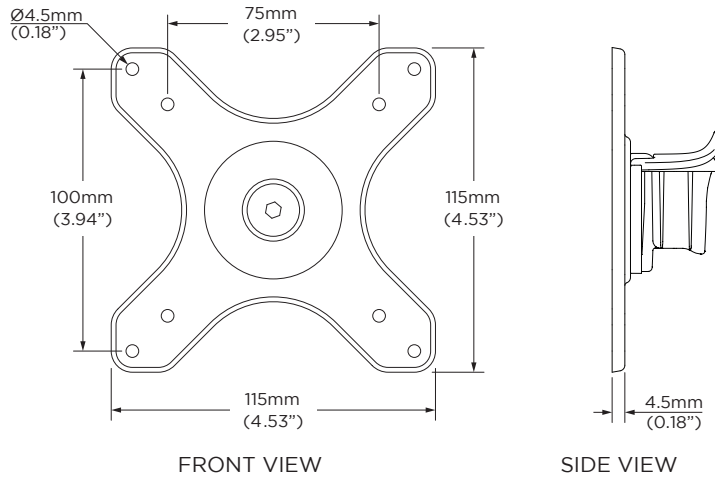

DESK FIXING OPTIONS

Below are the fixing options available for this solution. For more information and detailed specifications for these products please see the separate Technical Specifications available on the Atdec website.
 Note: Chosen desk fixing must be added to this solution code when ordering.

BOLT THROUGH AWM-FB

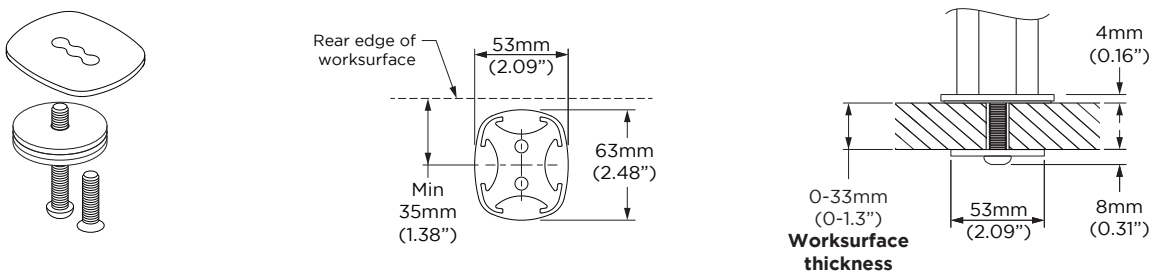

C CLAMP AWM-FC

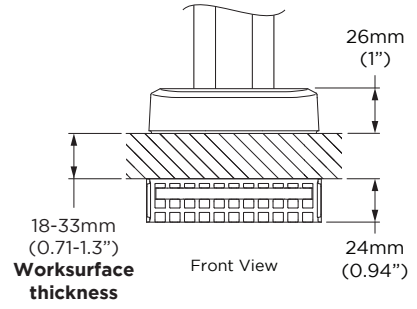
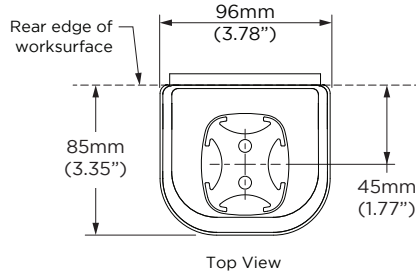
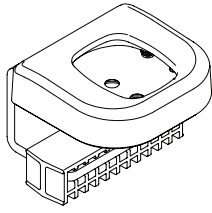

F CLAMP AWM-FF

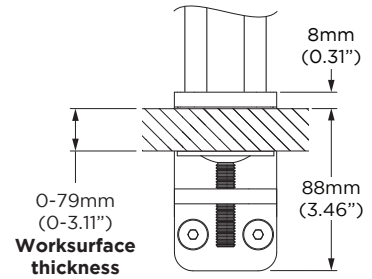
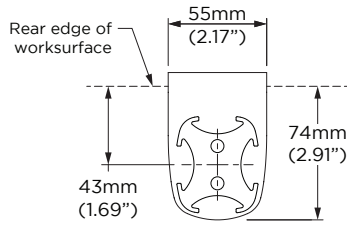
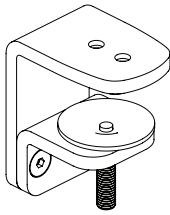

HEAVY DUTY F CLAMP AWM-FH

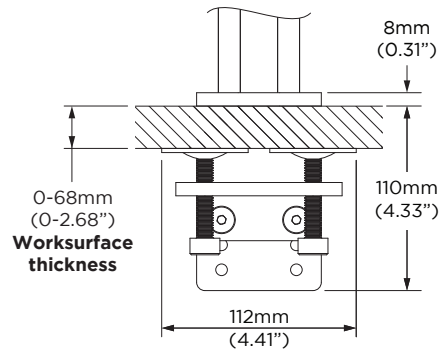
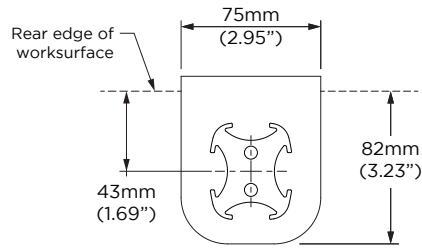
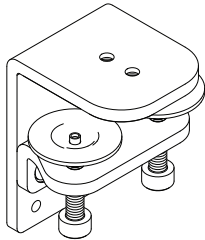

GROMMET CLAMP AC-GC

