

Display Pressure Transmitters



KT-302H Series PRODUCT MANUAL

For your safety, read and follow the considerations written in the instruction manual, other manuals and Autonics website.

The specifications, dimensions, etc. are subject to change without notice for product improvement. Some models may be discontinued without notice.

Features

- HART protocol
- Display rotation in 330 ° range
- Better visibility with supporting backlight function
- Excellent corrosion resistance with stainless steel housing
- High accuracy $\pm 0.2\%$ F.S.
- Self-stable and filter device
- Explosion-proof specification: Ex D IIC T6
- Protection structure: IP67 (IEC standard)

Safety Considerations

- Observe all 'Safety Considerations' for safe and proper operation to avoid hazards.
- **⚠** symbol indicates caution due to special circumstances in which hazards may occur.

⚠ Warning Failure to follow instructions may result in serious injury or death.

01. Fail-safe device must be installed when using the unit with machinery that may cause serious injury or substantial economic loss. (e.g. nuclear power control, medical equipment, ships, vehicles, railways, aircraft, combustion apparatus, safety equipment, crime/disaster prevention devices, etc.)
Failure to follow this instruction may result in personal injury, economic loss or fire.

02. Do not use the unit in the place where flammable/explosive/corrosive gas, high humidity, direct sunlight, radiant heat, vibration, impact or salinity may be present.
Failure to follow this instruction may result in explosion or fire.

03. The explosion proof standard of this unit is Ex d IIC T6, protection structure of this unit is IP67 and the range of max. surface temperature is below 85°C.

04. Do not disassemble or modify the unit.

Failure to follow this instruction may result in fire or electric shock.

⚠ Caution Failure to follow instructions may result in injury or product damage.

01. Do not apply beyond rated pressure.

Failure to follow this instruction may result in product damage.

02. Use the unit within the rated specifications.

Failure to follow this instruction may result in fire or product damage.

03. Keep the product away from metal chip, dust, and wire residue which flow into the unit.

Failure to follow this instruction may result in fire or product damage.

04. Check 'Connections' before wiring.

Failure to follow this instruction may result in explosion or fire.

05. This product is designed to detect the pressure of noncorrosive medium. Do not use for corrosive medium.

Failure to follow this instruction may result in product damage.

06. Use a dry cloth to clean the unit, and do not use water or organic solvent.

Failure to follow this instruction may result in fire or electric shock.

Cautions during Use

- Follow instructions in 'Cautions during Use'. Otherwise, it may cause unexpected accidents.
- Power supply should be insulated and limited voltage/current or Class 2, SELV power supply device.
- The connection of this unit should be separated from the power line and high voltage line in order to prevent inductive noise.
- Switch or circuit breaker should be installed nearby users for convenient control.
- Use verified explosion-proof cable gland or sealing fitting (explosion proof standard: over Ex d IIC T6, IP rating: over IP67 protection structure).
- Use dedicated external terminal for earth. For connecting earth, use a spring washer and earth cable which is over 4mm².

- This unit may be used in the following environments.
 - Indoor / Outdoor (in the environment condition rated in 'Specifications')
 - Altitude max. 2,000m
 - Pollution degree 2
 - Installation category II
- This explosion-proof unit is certified and the same specifications which is reported to Korea Gas Safety Corporation.**

Ordering Information

This is only for reference.
For selecting the specified model, follow the Autonics website.

KT-302H ① - ② ③ ④ ⑤

① Pressure type

S: Gauge, sealed gauge⁰¹⁾
A: Absolute

③ Install bracket

0: Without bracket
1: With bracket

② Rated pressure range

	Gauge	Absolute
01	0 to 35 kPa	0 to 35 kPa
02	0 to 0.1 MPa	0 to 0.1 MPa
03	0 to 0.2 MPa	0 to 0.2 MPa
04	0 to 0.7 MPa	0 to 0.7 MPa
05	0 to 2 MPa	0 to 2 MPa
06	0 to 3.5 MPa	0 to 3.5 MPa
07	0 to 7 MPa	
08	0 to 21 MPa	
09	0 to 35 MPa	
	Sealed gauge	
14	-0.1 to 0 MPa	-
15	-0.1 to 0.2 MPa	
16	-0.1 to 0.7 MPa	
17	-0.1 to 2 MPa	
18	-0.1 to 3.5 MPa	
Z	Custom	

④ Pressure port

0: G3/8 (PF, standard)
1: Others

⑤ User pressure range⁰²⁾

Customized pressure range

01) The pressure is sealed gauge pressure. The unit is sealed structure. It is based on atmospheric pressure 101.3 kPa (1.013 bar).

02) The pressure range is set to customized pressure range. (select "Z" at ② Rated pressure range)

Specifications

Series	KT-302H
Applicable medium	Gas, liquid, oil (except corrosive environment of SUS316)
Power supply	9 - 45 VDC \pm
Output	DC 4 - 20 mA (2-wire, low limit: 3.8 mA, high limit: 22.8 mA)
Accuracy ⁰¹⁾	$\pm 0.2\%$ of F.S. (at 25 °C)
Sampling period	200 ms
Display type	PV display part: 7 segment 5 digit, parameter display part: 16 segment 8 digit, bar LED: 52
Display range	-9999 to 99999
Setting method	Front key, HART-protocol
Approval	ERC
Unit weight (packaged)	≈ 1.4 kg (≈ 1.7 kg)
Ambient temperature	-20 to 70°C, storage: -40 to 85°C (rated at no freezing or condensation)
Ambient humidity	0 to 85%RH, storage: 0 to 85%RH (rated at no freezing or condensation)
Protection structure	IP67 (IEC standard)
Material	Body: aluminum (AlDc.8S), cover O - Ring: Buna N, diaphragm: SUS316, connection: SUS316
Explosion class ⁰²⁾	Ex d IIC T6

01) F.S. is rated pressure range.

02) This explosion class is acquired and managed by Konics co., ltd.

Dimensions

- Unit: mm, For the detailed drawings, follow the Autonics website.

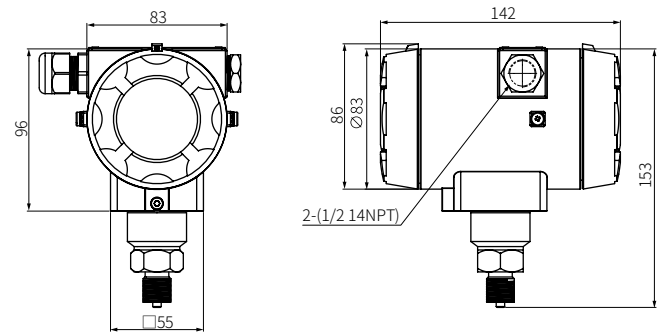

■ With bracket

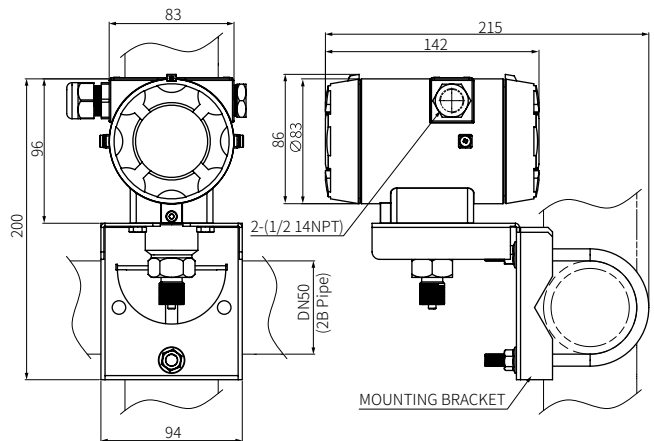

Connections

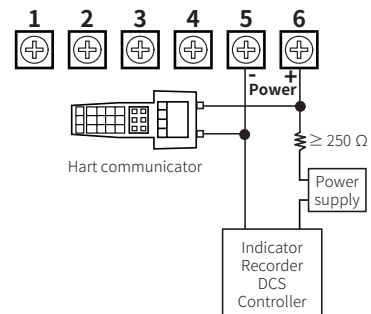

Opening the Cover

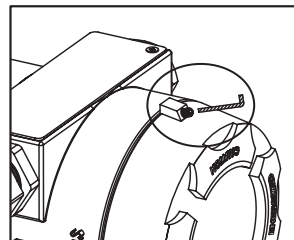

- To open the cover, unscrew the M3×6L headless bolt using a 1.5 hexagon wrench and rotate the cover.

Unit Descriptions

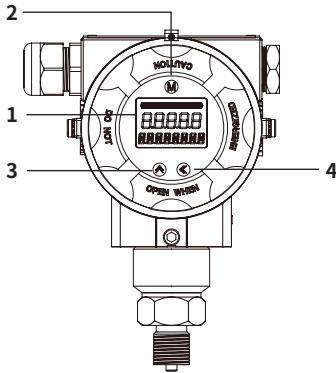

- 1. Display part**
Displays PV (present value) and the unit message.
- 2. [M] key**
Enters the setting mode and saves the setting value.
- 3. [▲] key**
Changes the setting value of data.
- 4. [◀] key**
Changes setting position of data.

Parameter Setting

- Some parameters are activated/deactivated depending on the model or setting of other parameters.
- [M]: Enters parameter setting mode, saves setting value or moves to the next parameter.
[◀]: Moves digit, [▲]: Changes setting value
- Do not press the [▲] and [◀] keys at the same time, or the product is reset and does not operate.

Parameter	Setting range	Unit
1 Zero-point adjustment	Z -9999 to 99999	3. Pressure unit
2 Measurement range	5 -9999 to 99999	3. Pressure unit
3 Pressure unit	U MPa, kPa, Pa, mmHg, mbar, bar, %, m, cm, kg, Torr, FtH ₂ O, inHg, atm, g/cm ² , inH ₂ O, kg/cm ² , mH ₂ O, psi	-
4 Response time	d AMP 0 to 99.9	sec
5 Display contents	d ISP mA, %, PV	-
6 Decimal point	d OT 0 to 3	-
7 Loop test	FIX C 3.8000, 4.0000, 8.0000, 12.000, 16.000, 20.000, 20.800	mA
8 Output type	U 7 LINE: linear, SQRT: square root	-

Functions

■ Zero-point adjustment

The current pressure value on display is set to zero forcibly by removing deviations from the open pressure port. Zero-point adjustment affects analog output.

- For precise measurement, execute zero-point adjustment periodically.

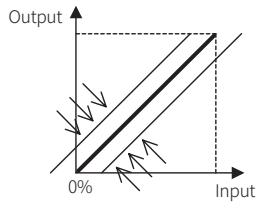

■ Measurement range

Sets the output range between maximum and minimum input.

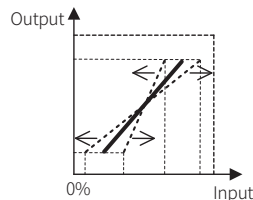

■ Response time

Sets the delay time that sensor input value is reflected in the output.

■ Loop test

Checks whether the set current value circulates normally through the connected circuit.

Pressure Conversion Table

	Pa	kgf/cm ²	mmHg	mmH ₂ O	psi	bar	inHg
Pa	1	0.000010197	0.007501	0.101972	0.00014504	0.00001	0.0002953
kgf/cm ²	98066.5	1	735.5592	10000.0005	14.223393	0.980665	28.959025
mmHg	133.3224	0.001359	1	13.595099	0.019337	0.001333	0.039370
mmH ₂ O	9.80665	0.000099	0.073556	1	0.00142	0.000098	0.002896
psi	6894.733	0.070307	51.71475	703.016716	1	0.068947	2.036014
bar	100000.0	1.019716	750.062	10197.1626	14.503824	1	29.529988
inHg	3386.388	0.034532	25.40022	345.315507	0.491156	0.033864	1

• 1,000,000 Pa = 1,000 kPa = 1 MPa

Segment Table

The segments displayed on the product indicate the following meanings. It may differ depending on the product.

7 segment				11 segment				12 segment				16 segment			
0	0	0	0	0	0	0	0	0	0	0	0	0	0	0	0
1	1	1	1	1	1	1	1	1	1	1	1	1	1	1	1
2	2	2	2	2	2	2	2	2	2	2	2	2	2	2	2
3	3	3	3	3	3	3	3	3	3	3	3	3	3	3	3
4	4	4	4	4	4	4	4	4	4	4	4	4	4	4	4
5	5	5	5	5	5	5	5	5	5	5	5	5	5	5	5
6	6	6	6	6	6	6	6	6	6	6	6	6	6	6	6
7	7	7	7	7	7	7	7	7	7	7	7	7	7	7	7
8	8	8	8	8	8	8	8	8	8	8	8	8	8	8	8
9	9	9	9	9	9	9	9	9	9	9	9	9	9	9	9
A	A	A	A	A	A	A	A	A	A	A	A	A	A	A	A
b	B	b	B	b	B	b	B	b	B	b	B	b	B	b	B
C	C	C	C	C	C	C	C	C	C	C	C	C	C	C	C
d	D	d	D	d	D	d	D	d	D	d	D	d	D	d	D
E	E	E	E	E	E	E	E	E	E	E	E	E	E	E	E
F	F	F	F	F	F	F	F	F	F	F	F	F	F	F	F
G	G	G	G	G	G	G	G	G	G	G	G	G	G	G	G
H	H	H	H	H	H	H	H	H	H	H	H	H	H	H	H