

Autonics RELAY TERMINAL BLOCK ABS Series INSTRUCTION MANUAL

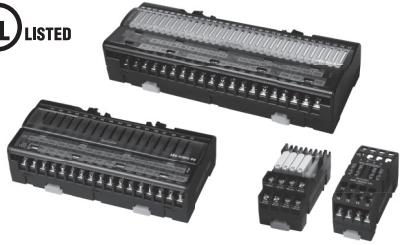

Thank you very much for selecting Autonics products.
For your safety, please read the following before using.

Safety Considerations

- Please observe all safety considerations for safe and proper product operation to avoid hazards.
- Safety considerations are categorized as follows.
- Warning** Failure to follow these instructions may result in serious injury or death.
- Caution** Failure to follow these instructions may result in personal injury or product damage.
- The symbols used on the product and instruction manual represent the following
- Symbol represents caution due to special circumstances in which hazards may occur.

Warning

- Fail-safe device must be installed when using the unit with machinery that may cause serious injury or substantial economic loss. (e.g. nuclear power control, medical equipment, ships, vehicles, railways, aircraft, combustion apparatus, safety equipment, crime/disaster prevention devices, etc.) Failure to follow this instruction may result in personal injury, fire, or economic loss.
- Do not repair, or inspect the unit while connected to a power source. Failure to follow this instruction may result in fire or electric shock.
- Do not use the unit where flammable or explosive gas, humidity, direct sunlight, radiant heat, vibration, or impact may be present. Failure to follow this instruction may result in fire or explosion.
- Do not disassemble or modify the unit. Please contact us if necessary. Failure to follow this instruction may result in electric shock, fire, or product damage.

Caution

- Do not use the unit outdoors. Failure to follow this instruction may result in shortening the life cycle of the unit, or electric shock.
- Use the unit within the rated specifications. Failure to follow this instruction may result in shortening the life cycle of the unit, or fire.
- Do not use water or oil-based detergent when cleaning the unit. Use dry cloth to clean the unit. Failure to follow this instruction may result in electric shock or product damage.
- Keep dust and wire residue from flowing into the unit. Failure to follow this instruction may result in fire or product damage.

Précautions pour la sécurité.

- Après avoir lu ce guide, s'il vous plaît, placez-le dans un lieu où vous pouvez récemment le trouver.
- S'il vous plaît suivre les conseils suivants pour la sécurité.
- Avertissement** L'inaccomplissement des instructions peut provoquer des blessures graves.
- Précaution** Le produit peut être endommagé ou de provoquer des blessures si les consignes ne sont pas respectées.
- La signification des icônes utilisées dans le produit et le manuel sont les suivants:
- Précaution: Blessure ou danger peuvent se produire dans des conditions particulières.

Avertissement

- Utilisez le produit seulement après avoir relié un double dispositif de sécurité pour les instruments qui ont un grand effet pour le corps humain et la propriété, comme sont les dispositifs d'énergie atomique, mets en oeuvre Médecine, de véhicules, Rails, aéronets, Brûleurs ou produits de sécurité. L'inaccomplissement peut causer des incendies, lésions personnelles ou dommages à la propriété. L'inaccomplissement peut causer des incendies, lésions personnelles ou dommages à la propriété.
- Ne pas réparer ou vérifier le produit tout alimenté. L'inaccomplissement peut provoquer un incendie ou des décharges électriques.
- Utilisez le produit avec l'environnement comme il est décrit dans le manuel. Évitez le lieu d'émission de gaz corrosifs, gaz inflammables, incorporation température, haute humidité, vibrations, choc, etc. L'inaccomplissement peut provoquer un incendie ou une explosion.
- Ne pas démonter et modifier cet appareil. S'il vous plaît nous contacter si cela est nécessaire. L'inaccomplissement pourrait causer des décharges électriques, incendies, lésions personnelles ou dommages à la propriété.

Précaution

- Cette unité ne doit pas être utilisé à l'extérieur. Peut raccourcir le cycle de vie du produit ou causer un choc électrique.
- S'il vous plaît respecter les spécifications nominales. L'inaccomplissement peut raccourcir le cycle de vie du produit et provoquer un incendie.
- Dans nettoyer l'appareil, n'utilisez pas d'eau ou de solvants organiques. Et utiliser un chiffon sec. L'inaccomplissement peut donner lieu des décharges électriques ou des dommages au produit.
- Ne pas laisser de poussière pénétrer l'unité. Cela pourrait provoquer un incendie ou un dysfonctionnement.

Ordering Information

AB	S	H	16	PA	N	N	Varistor installation	N	Not installed
							Input logic	C	COM None
							Relay type	N	NPN (COM+)
								P	PNP (COM-)
							Number of relay points	TN	TAKAMISAWA (Fujitsu) NYP
								PA	MATSUSHITA (Panasonic) PA
							Connector type	04	4
								16	16
								32	32
							Terminal type	H	Screw
								S	Hirose connector
								S	Screw
							Item	AB	Relay terminal block

Specifications

Model	ABS-S04PA-CN ABS-S04TN-CN	ABS-H16PA-NN(PN) ABS-H16TN-NN(PN)	ABS-H32PA-NN(PN) ABS-H32TN-NN(PN)
Power supply	24VDC ±10%		250VAC 2A, 30VDC 2A (2A/1point, 8A/1COM)
Rated load voltage & current ¹⁾	250VAC 3A, 30VDC 3A		
Current consumption	PA type TN type	Max. 10.5mA ²⁾ Max. 8.5mA ³⁾	Max. 10.5mA ²⁾ /Max. 15.5mA ³⁾ Max. 8.5mA ²⁾ /Max. 13.5mA ³⁾
Output type	1a contact relay output		
Applicable relay	PA: PA1a-24V (MATSUSHITA (Panasonic)), TN: NYP24W-K (TAKAMISAWA (Fujitsu))		
No. of relay points	4-point	16-point	32-point (8-point/1COM)
No. of connector pins	4-pin	20-pin	40-pin
Indicator	Operation indicator: Blue LED		Operation indicator: Red LED, Operation and disconnection indicator: Blue LED
Applicable wire	AWG22-16 (0.30 to 1.25mm ²)		
Insulation resistance	Min. 1,000MΩ (at 500VDC megger)		
Dielectric strength	Between coil-contact	2,000VAC 50/60Hz for 1 minute	
	Between same contacts ⁴⁾	1,000VAC 50/60Hz for 1 minute	
Vibration	Mechanical	0.75mm amplitude at frequency of 10 to 55Hz (for 1 min) in each X, Y, Z direction for 2 hours	
	Malfunction	0.75mm amplitude at frequency of 10 to 55Hz (for 1 min) in each X, Y, Z direction for 10 min	
Shock	Mechanical	500m/s ² (approx. 50G) in each X, Y, Z direction for 3 times	
	Malfunction	147m/s ² (approx. 15G) in each X, Y, Z direction for 3 times	
Environment	Ambient temp.	-15 to 55°C, storage: -25 to 65°C	
	Ambient humi.	35 to 85%RH, storage: 35 to 85%RH	
Material	CASE & BASE: Modified Polyphenylene Oxide, Polyethylene Oxide, TERMINAL PIN: Brass	CASE: Modified Polyphenylene Oxide, BASE: Polyamide 66 (G25%), TERMINAL PIN: Brass	
Tightening torque	5.1 to 6.1kgf·cm (0.5 to 0.6 N·m)		
Accessory ⁵⁾	Jumper bar: 2 (Model No. JB-7.62-04)		
Approval			
Weight ⁷⁾	PA type	Approx. 104g (approx. 68g)	Approx. 307g (approx. 224g) / Approx. 438g (approx. 345g)
	TN type	Approx. 107g (approx. 71g)	Approx. 318g (approx. 235g) / Approx. 463g (approx. 370g)

- Relay
- Coil specifications
- All values in the table are measured at 20°C with a tolerance of ±10%
- Model
- Rated voltage
- Must operate voltage
- Must release voltage
- Rated current
- Coil resistance
- Power consumption
- PA1a-24V
- 24VDC
- Min. 70% of rated voltage
- Max. 5% of rated voltage
- 7.5mA
- 3,200Ω
- 180mW
- NYP24W-K
- 24VDC
- 16.1V
- 2.4V
- 5mA
- 4,800Ω
- 120mW

2)Contact specifications		MATSUSHITA (Panasonic)		TAKAMISAWA (Fujitsu)	
Model	PA1a-24V	NYP24W-K			
Manufacture	Arrangement	1 Form A (SPST 1a)			
	Material	Au-clad AgNi type		Gold overlay silver alloy	
Contact	Resistance (initial)	Max. 30mΩ (at 1A 6VDC)			
	Rated load	5A 250VAC	5A 30VDC	3A 250VAC	3A 30VDC
Rating	Max. switching capacity	1,250VA	150W	750VA	90W
	Min. switching capacity	100mVDC 100uA		5VDC 1mA	
	Max. switching voltage	250VAC	110VDC	270VAC	150VDC
	Max. switching current	5A			
Electrical characteristics	Insulation resistance	Min. 1,000MΩ (at 500VDC megger)			
	Dielectric strength	Between contact-coil	2,000VAC 50/60Hz for 1 minute	3,000VAC 50/60Hz for 1 minute	
Mechanical characteristics	Surge voltage	4,000V		5,080V	
	Operate time	Max. 10ms			
	Release time	Max. 5ms			
	Vibration	Mechanical	3.5mm amplitude at frequency of 10 to 55Hz (for 1 min) in each X, Y, Z direction for 1 hour	5.0mm amplitude at frequency of 10 to 55Hz (for 1 min) in each X, Y, Z direction for 1 hour	
Shock	Mechanical	2.5mm amplitude at frequency of 10 to 55Hz (for 1 min) in each X, Y, Z direction for 10 minute	1.5mm amplitude at frequency of 10 to 55Hz (for 1 min) in each X, Y, Z direction for 10 minute		
	Malfunction	980m/s ² (approx. 100G) in each X, Y, Z direction for 3 times	100m/s ² (approx. 10G) in each X, Y, Z direction for 3 times		
Expected life	Mechanical	Min. 20,000,000 operations (at 180 times/min)			
	Electrical ¹⁾	Min. 100,000 operations (3A 250VAC, 30VDC resistive load)			
Environment	Ambient temperature	-40 to 70°C		-40 to 90°C	
	Ambient humidity	5 to 85%RH		35 to 80%RH	
Unit weight	Approx. 3g		Approx. 3.5g		

- 50,000 operations - 5A 250VAC, 30VDC resistive load. (per 20 operations/min)
- Environment resistance is rated at no freezing or condensation.

Installation

- Mounting and Removal at DIN rail
 - Mounting
 - Pull the rail lock towards direction ①.
 - Attach the DIN rail connection hook onto the DIN rail.
 - Push the unit towards direction ②, then push the rail lock in to lock into position.
 - Removal
 - Insert a screwdriver into the rail lock hole and pull it towards direction ①.
 - Remove the unit by pulling the unit towards direction ②.
 - Mounting with screws
 - The unit can be mounted on panels using the rear rail locks.
 - M4×15mm spring washer screws are recommended for installation. When using flat washers, use Ø6mm diameter washers. The tightening torque should be between 7.14 to 10.2kgf·cm (0.7 to 1.0N·m).
- The above specifications are subject to change and some models may be discontinued without notice.

Connections

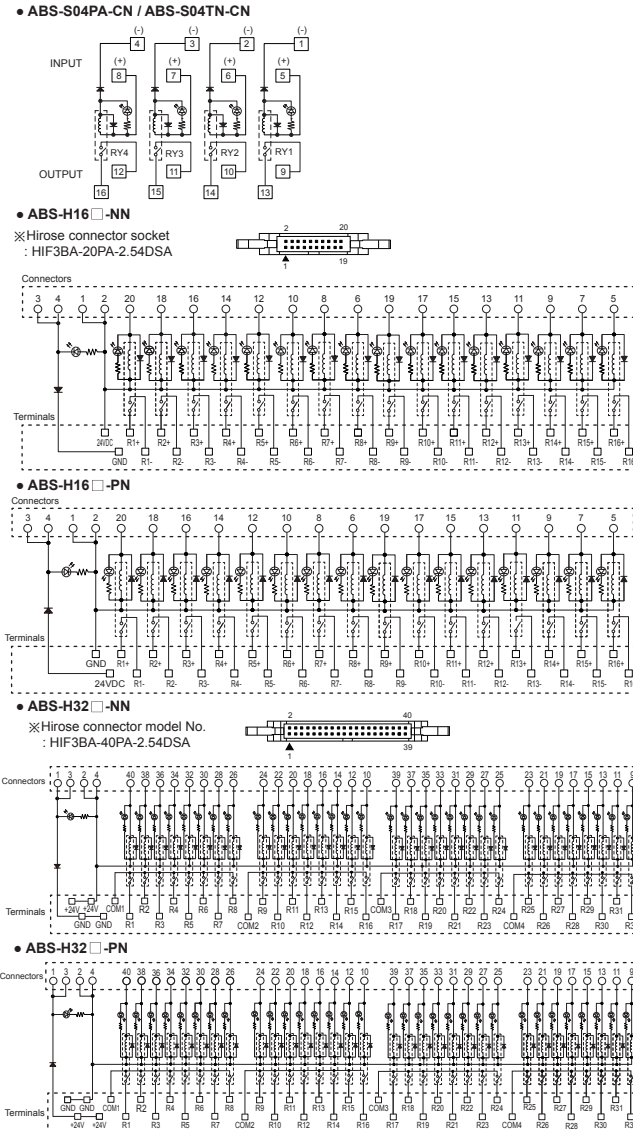

Crimp Terminal Specifications

	<Spade crimp terminal>		<Ring crimp terminal>		(unit: mm)
	A	B	C	D	Applicable wires
Spade crimp terminal	Min. 4.1	Max. 16.0	Min. 3.0	Max. 5.9	AWG 22-16
Ring crimp terminal	Min. 4.1	Max. 16.0	Min. 3.0	Max. 5.9	(0.30 to 1.25mm ²)

Please use UL certified crimp terminals.

Dimensions

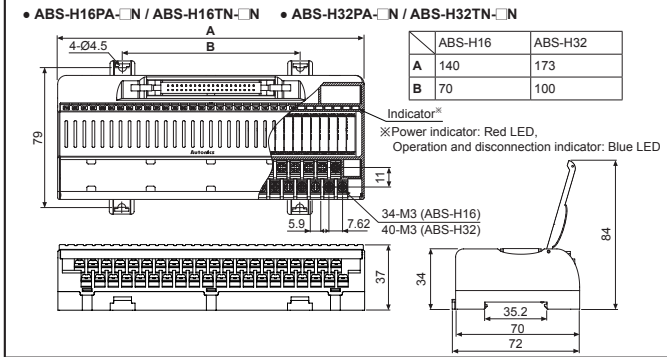
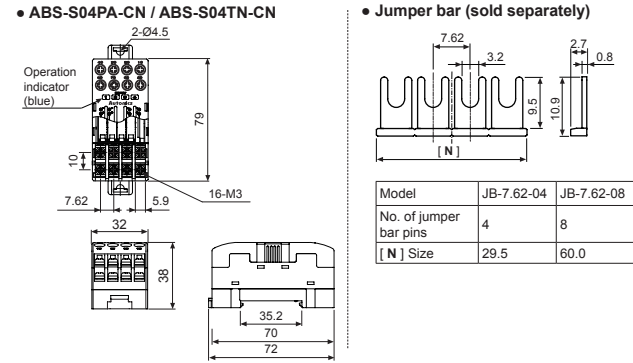

Installing Jumper Bars

- Cut the jumper bar to the user's desired length by cutting at the V dent using a nipper.
- Unfasten all the screws of the terminals you wish to commonize.
- Insert the jumper bar below the unfastened screws.
- Tighten all the screws above the jumper bar.

Replacing Relays

- Two way ejector position for relay replacement
 - Replacing for TAKAMISAWA (Fujitsu) relay
 - Replacing for MATSUSHITA (Panasonic) relay
 - Two way ejector
 - Two-way ejector for replacing relay
 - Two-way ejector for replacing relay
 - Removal and insert TAKAMISAWA (Fujitsu) relay
 - Removal and insert MATSUSHITA (Panasonic) relay
 - Remove relay >
 - Mount relay >
 - Remove relay >
 - Mount relay >
- Relay sockets are compatible with both TAKAMISAWA (Fujitsu) relay, NYP24W-K, and MATSUSHITA (Panasonic) relay, PA1a-24V.

Caution During Use

- Use the unit within the rated environment of specification.
 - Supply power within the rated allowable voltage range.
 - Check the polarity of power or COMMON before connecting PLC or other controllers.
 - When connecting the power input, use AWG22-16 (0.30 to 1.25mm²). For using crimp terminals, refer to 'Crimp Terminal Specifications'.
 - Do not connect wire, remove connector, or replace relays while connected to a power source.
 - Do not touch the unit immediately after the load power is supplied or cut. It may cause burn by high temperature.
 - Do not use the unit when screws are released. It may cause malfunction or burnout.
 - In case of 24VDC signal input, isolated and limited voltage/current or Class 2 source should be provided for power supply.
 - Do not use the unit at below places.
 - Environments with high vibration or shock.
 - Environments where strong alkalis or acids are used.
 - Environments with exposure to direct sunlight.
 - Near machinery which produce strong magnetic force or electric noise
 - This unit may be used in the following environments.
 - Altitude Max. 2,000m
 - Pollution Degree 2
 - Installation Category II
- Failure to follow these instructions may result in product damage.

Major Products

- Photoelectric sensors
- Fiber optic sensors
- Door sensors
- Door side sensors
- Area sensors
- Proximity sensors
- Pressure sensors
- Rotary encoders
- Connector/Sockets
- Switching mode power supplies
- Control switches/Lamps/Buzzers
- I/O Terminal Blocks & Cables
- Stepper motors/drivers/motion controllers
- Graphic/Logic panels
- Field network devices
- Laser marking system (Fiber, CO₂, Nd:YAG)
- Laser welding/cutting system
- Temperature controllers
- Temperature/Humidity transducers
- SSRs/Power controllers
- Counters
- Timers
- Panel meters
- Tachometer/Pulse (Rate)meters
- Display units
- Sensor controllers

Autonics Corporation
http://www.autonics.com

Trusted Partner In Industrial Automation

HEADQUARTERS:
18, Bansong-ro 513beon-gil, Haeundae-gu, Busan, South Korea. 48002

OVERSEAS SALES:
#402-303, Buechon Techno Park, 655, Pyeongcheon-ro, Wonmi-gu, Buechon, Gyeonggi-do, South Korea, 14502
TEL: 82-32-610-2730 / FAX: 82-32-329-0728
E-mail: sales@autonics.com

AS-KE-01-T0004G