

2-Phase Closed-Loop Stepper Motor Driver

■ Features

- Brake operation for safe control of vertical load at power OFF and alarm occur. (built-in brake type)
- Realized the closed loop with higher cost-efficiency compared to servo motor system
- Rapid response which is advantageous for the short distance continuous operation
- Able to implement Low frequency operation in low speed area and high torque in high speed area
- Easy to use as much as unskilled people can use with tuning unnecessary method (Gain setting with the switch)
- Applicable to the precision equipment such as optical inspection equipment with the features of maintaining torque in stop and having no micro vibration (hunting)
- Various resolutions
- Various alarms out
 - : overcurrent, overspeed, motor connection error, encoder connection error, and etc., overall 12 types
- Frame size 20mm, 28mm, 35mm, 42mm, 56mm, 60mm motors supported



SENSORS
CONTROLLERS
MOTION DEVICES
SOFTWARE

⚠ Please read "Safety Considerations" in the instruction manual before using.



■ Applications

- Filed requiring preciseness such as semiconductor equipment, 3D printer, optical inspection equipment, chip mounter, cartesian robot, conveying equipment, and alignment stage.

■ Ordering Information

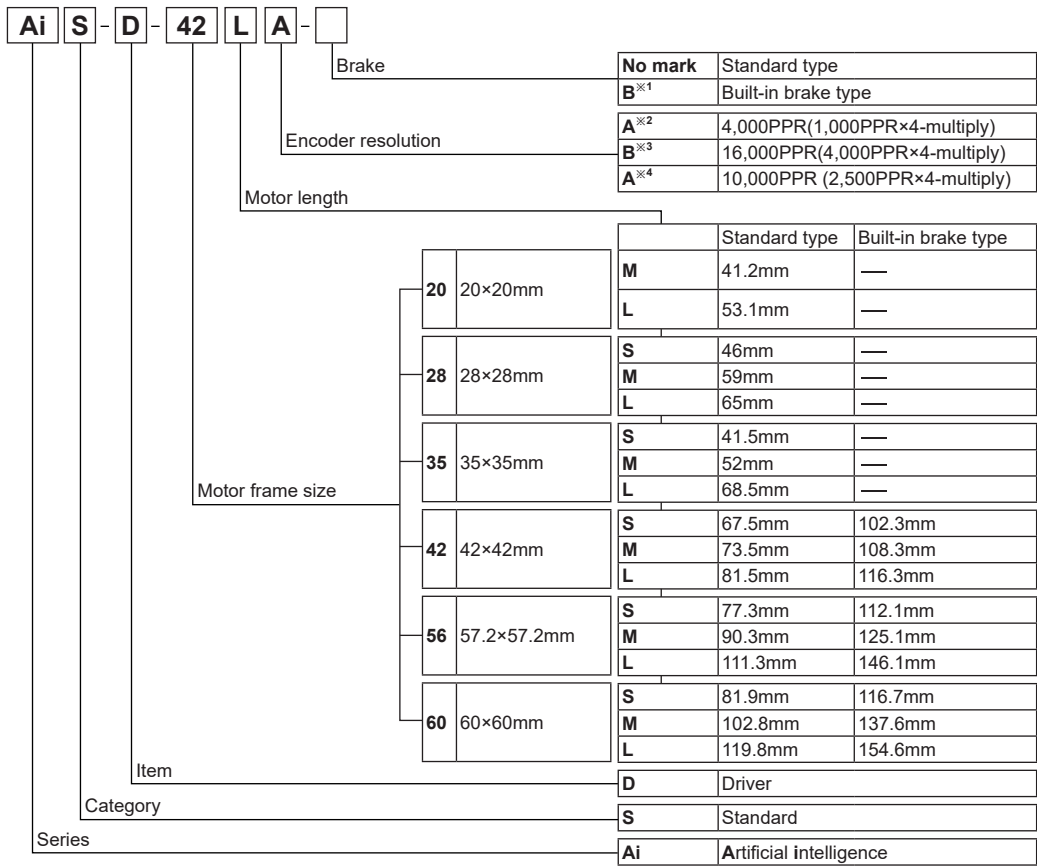

(Y) Closed Loop Stepper System
(Z) Stepper Motors
(AA) Drivers
(AB) Motion Controllers

※1: Built-in brake type is only for frame size 42, 56, 60mm motors.
 ※2: Encoder resolution for frame size 20mm motors.
 Microstep control for AiS driver, it controls up to 10,000PPR.
 ※3: Encoder resolution for frame size 28, 35mm motors.
 ※4: Encoder resolution for frame size 42, 56, 60mm motors.

AiS-D Series

Specifications

Model	AiS-D-20MA	AiS-D-20LA	AiS-D-28SB	AiS-D-28MB	AiS-D-28LB	AiS-D-35SB	AiS-D-35MB	AiS-D-35LB	AiS-D-42SA-□	AiS-D-42MA-□	AiS-D-42LA-□	AiS-D-56SA-□	AiS-D-56MA-□	AiS-D-56LA-□	AiS-D-60SA-□	AiS-D-60MA-□	AiS-D-60LA-□	
Power supply	24VDC=																	
Allowable voltage range	90 to 110% of the rated voltage																	
Power consumption	STOP ^{※1}	Standard type	Max. 10W						Max. 7W	Max. 7.5W	Max. 8W	Max. 9.5W	Max. 10W	Max. 11W	Max. 12W	Max. 13W	Max. 14W	
		Built-in brake type	—						Max. 16W	Max. 17W	Max. 23W		Max. 25W		Max. 26W			
Max. during operation ^{※2}		Standard type	Max. 50W		Max. 60W				Max. 60W			Max. 120W			Max. 240W			
		Built-in brake type	—		—				—			—			—			
Max. RUN current ^{※3}	0.6A/Phase		1.0A/Phase			1.2A/Phase			1.7A/Phase			3.5A/Phase						
STOP current	25% or 50% of max. RUN current (factory default: 50%)																	
Rotation speed	0 to 3,000rpm																	
Resolution	500 (factory default), 1000, 1600, 2000, 3600, 4000, 5000, 6400, 7200, 10000PPR		500 (factory default), 1000, 1600, 2000, 3600, 5000, 6400, 7200, 10000, 16000PPR					500 (factory default), 1000, 1600, 2000, 3200, 3600, 5000, 6400, 7200, 10000PPR										
Speed filter	0 (disable), 2, 4, 6, 8, 10, 20, 40, 60 (factory default), 80, 100, 120, 140, 160, 180, 200ms																	
Position control gain	(P Gain, I Gain)=(1, 1), (2, 1), (3, 1), (4, 1), (5, 1), (6, 1), (1, 2), (2, 2), (3, 2), (4, 2), (5, 2), (1, 3), (2, 3), (3, 3), (4, 3), (5, 3)																	
In-Position	Within the range of Fast response: 0 to 7 or Accurate response: 0 to 7																	
Pulse input method	1-pulse or 2-pulse input (factory default) method																	
Motor rotation direction	CW (factory default), CCW																	
Status indicator	<ul style="list-style-type: none"> • Power/Warning indicator: green LED • In-position indicator: yellow LED • Alarm indicator: red LED • Servo On/Off indicator: orange LED 																	
Input signal	RUN pulse, servo On/Off, alarm reset (photocoupler input)																	
Output signal	<ul style="list-style-type: none"> • In-position, alarm out (photocoupler output), • Encoder signal (A, \bar{A}, B, \bar{B}, Z, \bar{Z} phase, corresponding to 26C31) (line driver output), 						<ul style="list-style-type: none"> • In-position, alarm out (photocoupler output), • Encoder signal (A, \bar{A}, B, \bar{B}, Z, \bar{Z} phase, corresponding to 26C31) (line driver output), • Brake (built-in brake type) (at supplying moment: 24VDC for 0.2 sec, in normal status: 11.5VDC \pm10%) 											
Input pulse specifications	Pulse width	<ul style="list-style-type: none"> • CW, CCW : input pulse frequency duty 50% (min. 2μs), • Servo On/Off : min. 1ms, • Alarm reset : min. 20ms 		<ul style="list-style-type: none"> • CW, CCW : input pulse frequency duty 50% (min. 1.25μs), • Servo On/Off: min. 1ms, • Alarm reset: min. 20ms 				<ul style="list-style-type: none"> • CW, CCW: input pulse frequency duty 50%, • Servo On/Off: min. 1ms, • Alarm reset: min. 20ms 										
	Rising/Falling time	CW, CCW: max. 0.5 μ s																
	Pulse input voltage	• CW, CCW - [H]: 4-8VDC=, [L]: 0-0.5VDC • Servo On/Off, alarm reset - [H]: 24VDC=, [L]: 0-0.5VDC																
	Max. input pulse freq. ^{※4}	CW, CCW: 500kHz																
Input resistance	220 Ω (CW, CCW), 10k Ω (servo On/Off, alarm reset)																	
Insulation resistance	Over 100M Ω (at 500VDC megger)																	
Dielectric strength	1,000VAC 60Hz for 1 min																	
Vibration	1.5mm amplitude at frequency 10 to 55Hz (for 1 min) in each X, Y, Z direction for 2 hours																	
Shock	300m/s ² (approx. 30G) in each X, Y, Z direction for 3 times																	
Environment	Ambient temp.	0 to 50°C, storage: -20 to 70°C						0 to 50°C, storage: -10 to 60°C (standard type), -20 to 70°C (built-in brake type)										
	Ambient humi.	35 to 85%RH, storage: 10 to 90%RH																
Approval	CE																	
Protection structure	IP20 (IEC standard)																	
Weight ^{※5}	Approx. 400g (approx. 290g)																	

※1: Based on the ambient temperature 25°C, ambient humidity 55%RH, and STOP current 50%.

※2: Max. power consumption during operation. When changing the load rapidly, instantaneous peak current may increase. The capacity of power supply should be over 1.5 to 2 times of max. power consumption.

※3: RUN current varies depending on the input RUN frequency and max. RUN current at the moment varies also.

※4: Max. input pulse frequency is max. frequency to be input and is not the same as max. pull-out frequency or max. slewing frequency.

※5: The weight includes packaging. The weight in parenthesis is for unit only.

※Environment resistance is rated at no freezing or condensation.

2-Phase Closed-Loop Stepper Motor Driver

Configuration Diagram

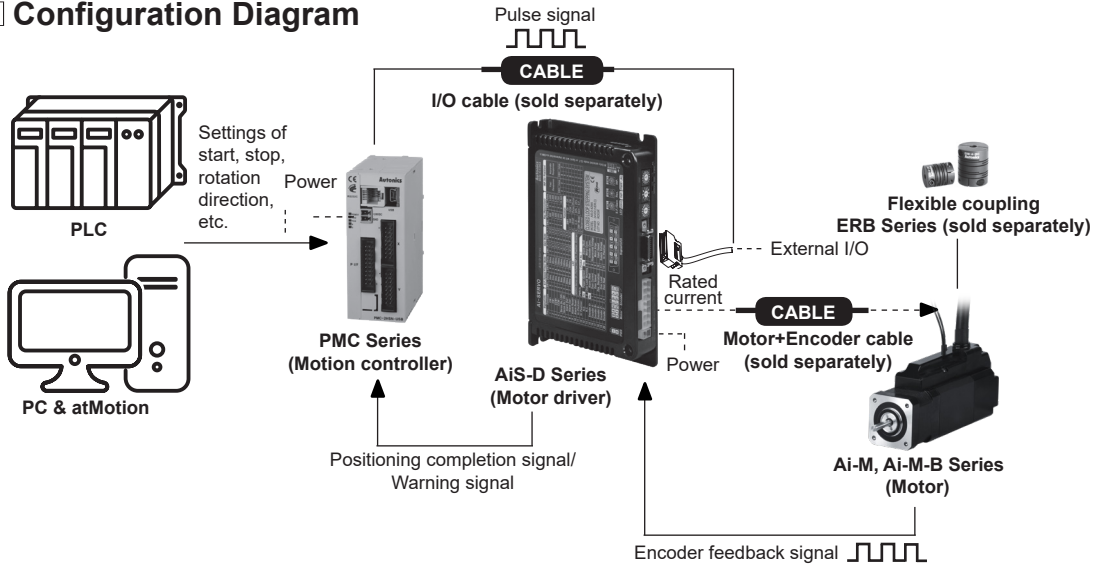

SENSORS
CONTROLLERS
MOTION DEVICES
SOFTWARE

(Y) Closed Loop Stepper System
(Z) Stepper Motors
(AA) Drivers
(AB) Motion Controllers

Dimensions

(unit: mm)

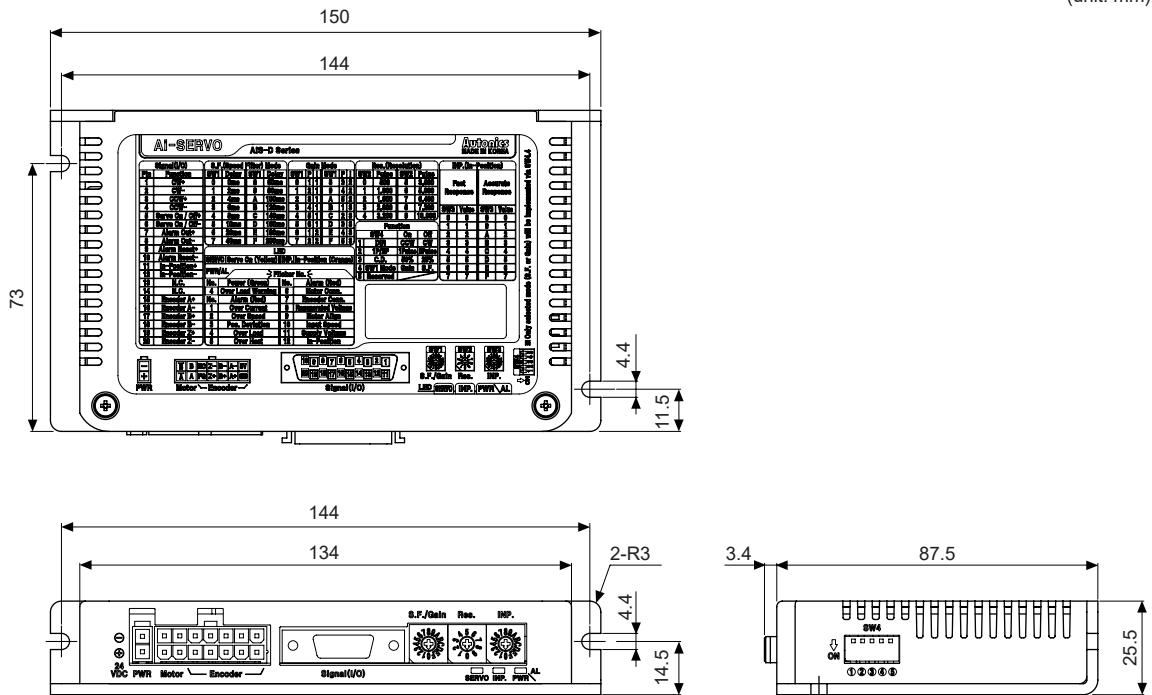

Driver Status Indicators

Status indicator	LED color	Function	Descriptions
PWR	Green	Power indicator	Turns ON when the unit operates normally after supplying power
		Warning indicator	Flashes when over load status is maintained
AL	Red	Alarm indicator	When alarm occurs, it flashes in various ways depending on the situation. Refer to 'Control Input/Output → Output → 2. Alarm/Warning'
INP.	Yellow	In-Position indicator	Turns ON when motor is placed at command position after positioning input.
SERVO	Orange	Servo On/Off indicator	Turns ON when servo is operating, turns OFF when servo is not operating.

Driver Unit Descriptions

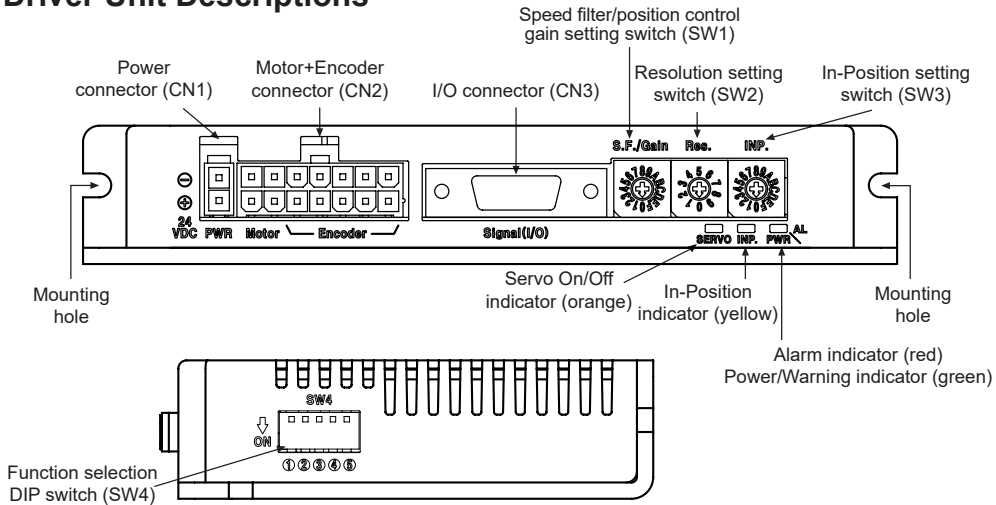

Driver Setting

SW1: Speed filter setting switch or position control gain setting switch

-SW1 shifts its mode between the speed filter setting or the position control gain setting, depending on 4th pin in SW4 as follows.
 -Modified setting values are not applied in the running status, and the values will be applied after motor stopped.

4th pin in SW4	Setting
OFF	Speed filter
ON	Position control gain

Speed filter setting

-Speed filter decides operation responsiveness of the motor to input pulse.
 -Set the delay time between the position of input pulse and the position of motor to prevent load changing or disturbance with soft operation function.
 ※If the setting value is too high, the synchronous response by command is decreased.

Setting switch	Setting	Delay time	Setting	Delay time
 S.F./Gain	0	Disable	8 ^{※1}	60ms
	1	2ms	9	80ms
	2	4ms	A	100ms
	3	6ms	B	120ms
	4	8ms	C	140ms
	5	10ms	D	160ms
	6	20ms	E	180ms
	7	40ms	F	200ms

※1: Factory default

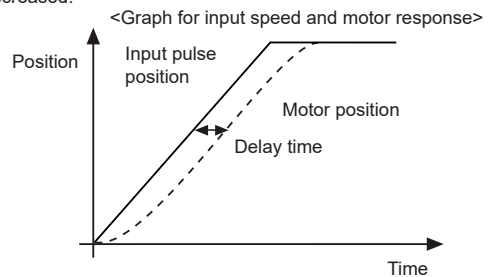

Position control gain setting

-Position control gain decides responsiveness of the motor to position command.
 -Gain setting in motor stationary state, depending on load of motor, realizes rapid positioning and stabilized performance.
 -P_Gain: Adjust vibration in running drive.
 -I_Gain: Adjust vibration in accelerating/decelerating drive.

Setting switch	Setting	Gain		Setting	Gain	
		P	I		P	I
 S.F./Gain	0	1	1	8 (factory default)	3	2
	1	2	1	9	4	2
	2	3	1	A	5	2
	3	4	1	B	1	3
	4	5	1	C	2	3
	5	6	1	D	3	3
	6	1	2	E	4	3
	7	2	2	F	5	3

2-Phase Closed-Loop Stepper Motor Driver

◎ SW2: Resolution setting switch

-Set the resolution of driver.

-Refer to the table below for the number of pulses per 1 rotation by resolution.

-Modified setting values are not applied in the running status, and the values will be applied after motor stopped.

Setting switch	Setting	Frame size 20mm		Frame size 28/35mm		Frame size 42/56/60mm	
		Pulse/Revolution	Resolution	Pulse/Revolution	Resolution	Pulse/Revolution	Resolution
	0 (factory default)	500	2.5	500	2.5	500	2.5
	1	1000	5	1000	5	1000	5
	2	1600	8	1600	8	1600	8
	3	2000	10	2000	10	2000	10
	4	3600	18	3600	18	3200	16
	5	4000	20	5000	25	3600	18
	6	5000	25	6400	32	5000	25
	7	6400	32	7200	36	6400	32
	8	7200	36	10000	50	7200	36
	9	10000	50	16000	80	10000	50

◎ SW3: In-Position setting switch

-After position command pulse has finished, if the gap between target position and real position is under In-Position setting value, positioning completion pulse is output.

-Modified setting values are not applied in the running status, and the values will be applied after motor stopped.

Setting switch	Fast response		Accurate response	
	Setting	Value	Setting	Value
	0 (factory default)	0	8	0
	1	±1	9	±1
	2	±2	A	±2
	3	±3	B	±3
	4	±4	C	±4
	5	±5	D	±5
	6	±6	E	±6
	7	±7	F	±7

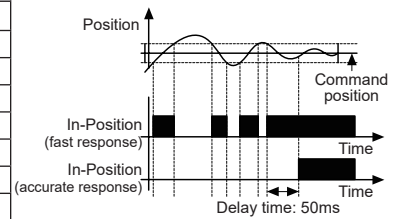

◎ SW4: Function selection DIP switch

-Set rotation direction, pulse input method, STOP current, SW1 setting, and test mode.

Setting switch	No.	Name	Function	Switch position	
				ON	OFF (factory default)
	1 ^{※1}	DIR	Rotation direction	CCW	CW
	2 ^{※1}	1P/2P	Pulse input method	1-pulse input method	2-pulse input method
	3 ^{※2}	C.D.	STOP current	25% of max. RUN current	50% of max. RUN current
	4 ^{※2}	SW1 Mode	SW1 setting	Position control gain	Speed filter
	5 ^{※3}	Reserved	Test mode	Test mode	Normal mode

※1: When motor runs or stops, modified setting values will be applied immediately.

※2: Modified setting values are not applied in the running status, and the values will be applied after motor stopped.

※3: Set to OFF when using the device. It is only for the operation test in manufacturing process.

● Pulse input method

※1-pulse input method

CW: rotation operation signal input

CCW: rotation direction signal input

([H]: forward rotation, [L]: reverse rotation)

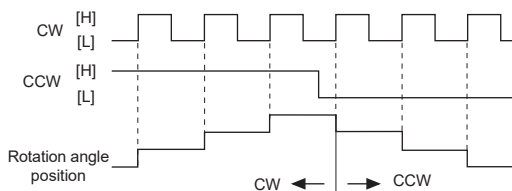

※2-pulse input method

CW: forward rotation signal input

CCW: reverse rotation signal input

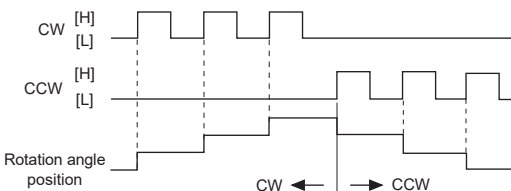

※[H]: photocoupler ON (voltage of both ends 4-8VDC) [L]: photocoupler OFF (voltage of both ends 0-0.5VDC)

● STOP current

-In order to decrease motor heat and current consumption at motor stopping moment (in case there is no input during the time of the double width of last input pulse), set the stop current supplied to the motor phase.

SENSORS

CONTROLLERS

MOTION DEVICES

SOFTWARE

(Y) Closed Loop Stepper System

(Z) Stepper Motors

(AA) Drivers

(AB) Motion Controllers

Control Input/Output

Inner signal of all input/output consists of photocoupler.

ON, [H]: photocoupler power ON / OFF, [L]: photocoupler power OFF.

※Brake operation is only for built-in brake type.

Input

1. Position command pulse

- Pulse input is selectable from 1-pulse input method and 2-pulse input method. (Refer to '◎ SW4: Function selection DIP switch'.)

- When using extending cable, it is recommended to connect Common mode choke coil (2mH) to the CW, CCW terminal in series connection.

2. Servo On/Off

-Servo On/Off signal maintains over 1ms as [H]: Regarded as Servo Off signal and phase current is cut to release torque.

The Servo On indicator, the In-Position output and indicator turns OFF. Brake operates.

-Servo On/Off signal maintains over 1ms as [L]: Regarded as Servo On signal and phase current is supplied to gain torque.

The Servo On indicator, the In-Position output and indicator turns ON. Brake is released.

※Use this function after stopping the motor.

※Refer to '4. Example of input circuit connection'.

3. Alarm Reset

-This signal is for clearing the alarm.

-Alarm reset signal maintains over 20ms as [H]: Alarm is cleared, the alarm indicator and alarm output turns OFF, and the driver returns to normal status. Brake is released.

※If the causes of the alarm are not removed, driver may not be returned to the normal status even with alarm reset.

※Refer to '4. Example of input circuit connection'.

4. Example of input circuit connection

• Input pulse (CW, CCW)

-It is recommended to use 5VDC at V_{CC} and short the R_L .

-In case V_{CC} is over 5VDC, calculate R_L value using following formula and use V_{CC} below 30VDC. $\text{※}R_L = \frac{V_{CC}-2.17V}{0.011A} - 220\Omega$

-In case V_{CC} is 12, 24VDC, refer to the table below for R_L .

V_{CC}	R_L
12VDC	680Ω (min. 0.25W)
24VDC	1.8kΩ (min. 0.5W)

A. Pull-Up

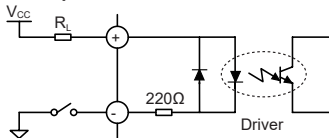

B. Pull-Down

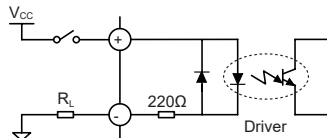

C. Circuit with NPN (not-reversed)

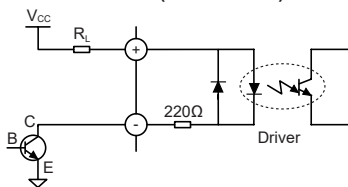

D. Circuit with PNP (reversed)

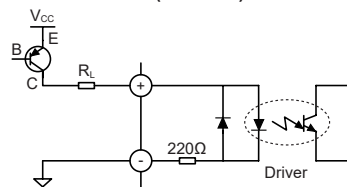

• External input (Servo On/Off, Alarm Reset)

A. Pull-Up

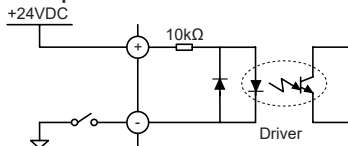

B. Pull-Down

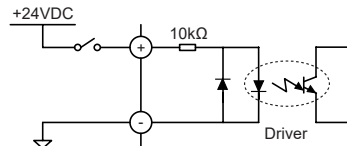

C. Circuit with NPN (not-reversed)

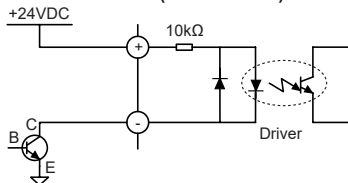

D. Circuit with PNP (reversed)

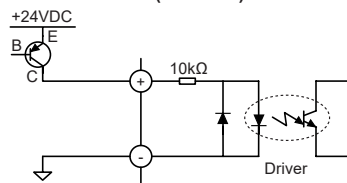

2-Phase Closed-Loop Stepper Motor Driver

◎ Output

1. In-Position

- In-Position output is output condition of positioning completion signal.
- If the gap between target position and real position is under In-Position setting value after position command pulse has finished, In-Position output turns to [H] and the In-Position indicator turns ON.
- In reverse, when the gap is over In-Position setting value, In-Position output turns to [L] and In-Position indicator turns OFF.
- For accurate drive, check the In-Position output again and execute the next drive.
- ※Refer to '3. Example of output circuit connection'.

2. Alarm/Warning

- Alarm
 - This function stops motor to protect driver, depending on the error status such as over current or over speed.
 - In case of normal status, output is [H], and in case of alarming status, output is [L].
 - When supplying alarm reset, driver returns to the normal status.
 - ※Refer to '3. Example of output circuit connection'.
- Warning
 - This function notices dangers with the alarm indicator prior to over load alarm.
 - When turning out from the alarming condition, driver returns to the normal status automatically.

Alarm indicator	No. of flashing	Alarm type	Descriptions	Motor stop	Maintain torque	
AL (red)	1	Overcurrent error	When over current flows at motor RUN element	O	x	
	2	Overspeed error	When motor speed is over 4,000rpm			
	3	Position tracking error	When the gap between position command value and current position value is over 90°			
	4	Overload error	When applying load over the rated load for over 1 sec			
	5	Overheat error	When driver inner temperature is over 80°C			
	6	Motor connection error	When motor cable connection error occurs at driver			
	7	Encoder connection error	When encoder cable connection error occurs at driver			
	8	Regenerative voltage error	When regenerative voltage is over 78V			
	9	Motor misalignment	When motor is in misalignment			
	10	Command pulse error	When Input pulse is over 3,500rpm			
	11	Input voltage error	Frame size 20, 28, 35mm			When Input voltage is out of 21-27VDC ±5%
			Frame size 42, 56, 60mm			When Input voltage is out of 24VDC ±10%
12	In-Position error	When position error (over 1) is kept over 3 sec, after motor stopped.				
Warning indicator	No. of flashing	Warning type	Descriptions	Motor stop	Maintain torque	
PWR (green)	4	Overload warning	When maximum load is kept connected over 10 sec. (motor or driver can be overheated)	x	O	

※Even though warning occurs, it drives as normal status and it may cause damage by fire.

It is recommend not to use the unit during warning status.

※Depending on the alarm/warning type, it flashes for 0.4 sec interval and it turns OFF for 0.8 sec repeatedly.

< E.g. case of alarm 3 >

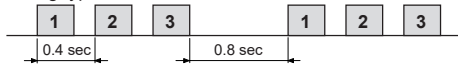

3. Example of output circuit connection

-It is recommend to use below 50VDC at V_{CC} .

Use the R_L for I_C (collector current of secondary detector) of photocoupler inside the driver to be within 25mA following the below formula.

$$\text{※A: } R_L = \frac{V_{CC} - 0.3V - V_F}{0.025A} - 10\Omega \quad \text{※B, C: } R_L = \frac{V_{CC} - 0.3V}{0.025A} - 10\Omega$$

(V_F is LED forward voltage of primary photocoupler.)

A. Circuit with photocoupler

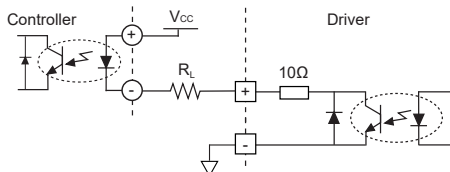

B. Circuit with pull up (reversed)

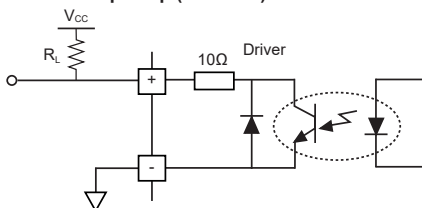

C. Circuit with pull down (not-reversed)

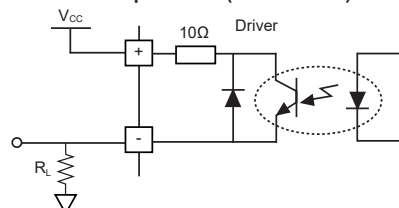

SENSORS
CONTROLLERS
MOTION DEVICES
SOFTWARE

(Y) Closed Loop Stepper System
(Z) Stepper Motors
(AA) Drivers
(AB) Motion Controllers

AiS-D Series

4. Encoder output waveforms

◎ Frame size 20, 28, 35mm

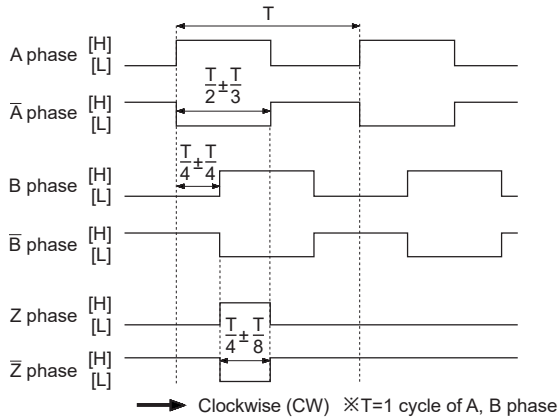

◎ Frame size 42, 56, 60mm

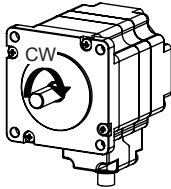
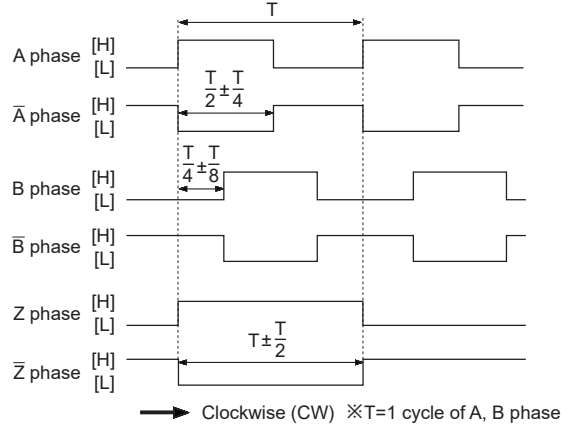

※It is recommended to use Line driver output (corresponding to 26C32) at RECEIVER end of encoder output and terminating resistors (100-150Ω) in parallel at both ends of each phase (A, \bar{A} , B, \bar{B} , Z, \bar{Z} , corresponding to 26C31).

5. Brake output

-In order to reduce heat in the brake, connected to the motor, the driver outputs DC power to turn off the brake.

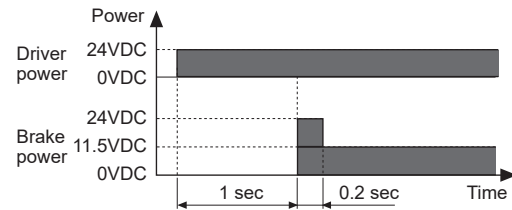

-When supplying power to the driver after connecting the driver and brake, the rated excitation voltage is supplied and the brake power is released after approx. 1 sec.

Then after approx. 0.2 sec, the excitation voltage is decreased to 11.5VDC and the released brake power is maintained.

※While power is supplied to the driver, the brake is kept turning on, except in the Servo On status.

■ Driver Connectors

◎ Connector function

● CN1: Power connector

Pin arrangement	Pin no.	Function
	2	GND
	1	24VDC

● CN2: Motor+Encoder Connector

Pin arrangement	Pin no.	Function	Pin no.	Function
	1	GND	8	+5VDC
	2	Encoder A	9	Encoder \bar{A}
	3	Encoder B	10	Encoder \bar{B}
	4	Encoder Z	11	Encoder \bar{Z}
	5	F.G.	12	N·C
	6	Motor A	13	Motor B
	7	Motor \bar{A}	14	Motor \bar{B}

2-Phase Closed-Loop Stepper Motor Driver

■ Driver Connectors

● CN3: I/O connector

Pin arrangement	Pin no.	Input/Output	Function	Pin no.	Input/Output	Function
	1	Input	CW+	11	Output	In-Position+
	2	Input	CW-	12	Output	In-Position-
	3	Input	CCW+	13	Output	Brake+
	4	Input	CCW-	14	Output	Brake-
	5	Input	Servo On/Off+	15	Output	Encoder A
	6	Input	Servo On/Off-	16	Output	Encoder Ā
	7	Output	Alarm Out+	17	Output	Encoder B
	8	Output	Alarm Out-	18	Output	Encoder B̄
	9	Input	Alarm Reset+	19	Output	Encoder Z
	10	Input	Alarm Reset-	20	Output	Encoder Z̄

◎ Connector specifications

Type		Specifications			Manufacture
		Connector	Connector terminal	Housing	
CN1	Driver	0039301020	—	—	Molex
	Power	CHD1140-02	CTD1140	—	HANLIM
CN2	Driver	35318-1420	—	—	Molex
	Motor+ Encoder	Frame size 20, 28, 35mm Frame size 42, 56, 60mm	5557-14R	5556T2 5556T	Molex
CN3	Driver	10220-52A2 PL	—	—	3M
		10120-3000PE	—	10320-52F0-008	3M
	I/O connector	CJ-MP20-HP□ (sold separately)	—	—	Autonics

※Above connectors are suitable for AiS-D Series. You can use equivalent or substitute connectors.

■ Sold Separately

◎ Power cable

● CJ-PW-□

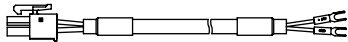

※□ of model name indicates cable length (010, 020)
E.g.) CJ-PW-010: 1m power cable.

◎ I/O cable

● CJ-MP20-HP□

(standard: AiS TAG)

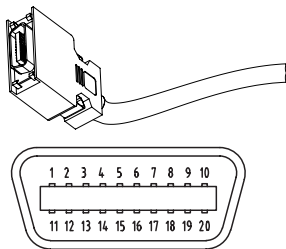

Pin no.	Function (name tag)	Cable color	Dot line color-numbers	Pin no.	Function (name tag)	Cable color	Dot line color-numbers
1	CW+	Yellow	Black-1	11	In-Position+	White	Black-1
2	CW-		Red-1	12	In-Position-		Red-1
3	CCW+		Black-2	13	Brake+		Black-2
4	CCW-		Red-2	14	Brake-		Red-2
5	Servo On/Off+		Black-3	15	Encoder A+		Black-3
6	Servo On/Off-		Red-3	16	Encoder A-		Red-3
7	Alarm Out+		Black-4	17	Encoder B+		Black-4
8	Alarm Out-		Red-4	18	Encoder B-		Red-4
9	Alarm Reset+		Black-5	19	Encoder Z+		Black-5
10	Alarm Reset-		Red-5	20	Encoder Z-		Red-5

※□ of model name indicates cable length (010, 020, 030, 050, 070, 100, 150, 200)
E.g.) CJ-MP20-HP070: 7m I/O cable.

◎ Motor+Encoder cable

● Normal: C1D14M-□, Moving: C1DF14M-□

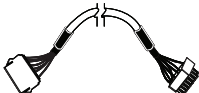

※□ of model name indicates cable length (1, 2, 3, 5, 7, 10)
E.g.) C1DF14M-10: 10m moving type motor+encoder cable.

SENSORS

CONTROLLERS

MOTION DEVICES

SOFTWARE

(Y) Closed Loop Stepper System

(Z) Stepper Motors

(AA) Drivers

(AB) Motion Controllers

AiS-D Series

■ Connection for Motor and Driver

○ Standard type, Frame size 20, 28, 35mm

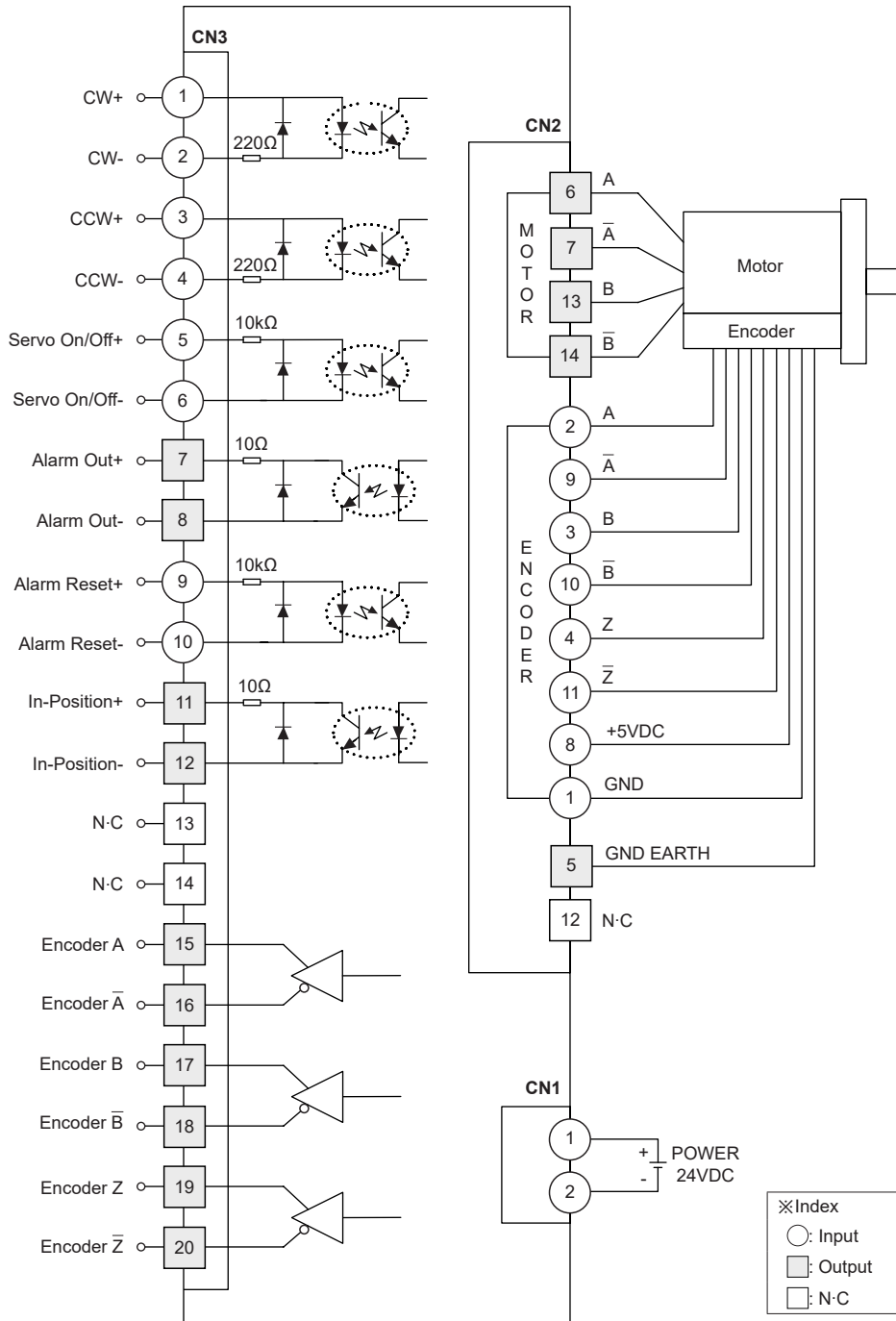

2-Phase Closed-Loop Stepper Motor Driver

■ Connection for Motor and Driver

◎ Standard / Brake type, Frame size 42, 56, 60mm

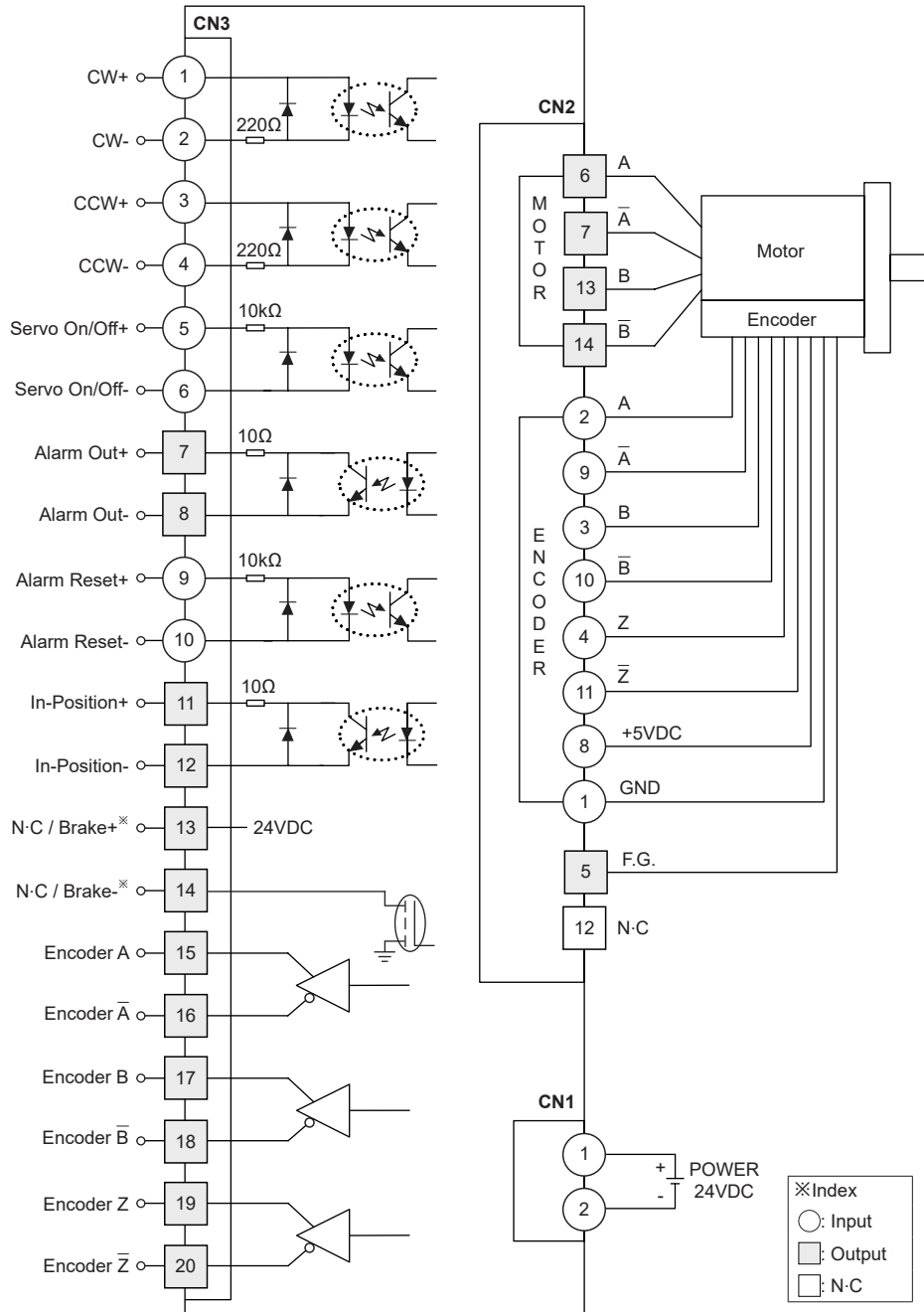

※For standard type, pin 13: N-C
pin 14: N-C
For brake type, pin 13: Brake+
pin 14: Brake-

SENSORS
CONTROLLERS
MOTION DEVICES
SOFTWARE

(Y) Closed Loop Stepper System
(Z) Stepper Motors
(AA) Drivers
(AB) Motion Controllers

■ Troubleshooting

1. When motor does not rotate

- ① Check the connection status between controller and driver, and pulse input specifications (voltage, width).
- ② Check the pulse and direction signal are connected correctly.

2. When motor rotates to the opposite direction of the designated direction

- ① When RUN mode is 1-pulse input method, CCW input [H] is for forward, [L] is for backward.
- ② When RUN mode is 2-pulse input method, check CW and CCW pulse input are changed or not.

3. When motor drive is unstable

- ① Check that driver and motor are connected correctly.
 - ② Check the driver pulse input specifications (voltage, width).
-

■ Proper Usage

- Follow instructions in 'Proper Usage'. Otherwise, it may cause unexpected accidents.
- 24VDC power supply should be insulated and limited voltage/current or Class 2, SELV power supply device.
- Re-supply power after min. 1 sec from disconnected power.
- Do not input CW, CCW signal at the same time in 2-pulse input method.
- When the signal input voltage is exceeded the rated voltage, connect additional resistance at the outside.
- Use twisted pair (over 0.2mm²) for the signal cable which should be shorter than 2m.
- The thickness of cable should be same or thicker than the motor cable's when extending the motor cable.
- Keep the distance between power cable and signal cable more than 10cm.
- Motor vibration and noise can occur in specific frequency period.
 - ① Change motor installation method or attach the damper.
 - ② Use the unit out of the dedicated frequency range when vibration and noise occurs due to changing motor RUN speed.
- For using motor, it is recommended to maintenance and inspection regularly.
 - ① Unwinding bolts and connection parts for the unit installation and load connection
 - ② Strange sound from ball bearing of the unit
 - ③ Damage and stress of lead cable of the unit
 - ④ Connection error with motor
 - ⑤ Inconsistency between the axis of motor output and the center, concentric (eccentric, declination) of the load, etc.
- This product does not prepare protection function for a motor.
- This unit may be used in the following environments.
 - ① Indoors (in the environment condition rated in 'Specifications')
 - ② Altitude max. 2,000m
 - ③ Pollution degree 2
 - ④ Installation category II