

# Autonics

## PHOTOELECTRIC SENSOR BJN SERIES

### M A N U A L



Thank you very much for selecting Autonics products.  
For your safety, please read the following before using.

### Caution for your safety

- ※Please keep these instructions and review them before using this unit.
- ※Please observe the cautions that follow;
  - Warning** Serious injury may result if instructions are not followed.
  - Caution** Product may be damaged, or injury may result if instructions are not followed.
- ※The following is an explanation of the symbols used in the operation manual.
- ⚠Caution: Injury or danger may occur under special conditions.

### Warning

- In case of using this unit with machinery (Ex: nuclear power control, medical equipment, ship, vehicle, train, airplane, combustion apparatus, safety device, crime/disaster prevention equipment, etc) which may cause damages to human life or property, it is required to install fail-safe device.**  
It may cause a fire, human injury or damage to property.
- Do not disassemble or modify this unit. Please contact us if it is required.**  
It may cause electric shock or a fire.

### Caution

- This unit shall not be used outdoors.**  
It might shorten the life cycle of the product or give an electric shock. Use this product inside only. Do not use the product outdoors or location subject to temperatures or humidity outside.(Ex: rain, dirty, frost, sunlight, condensation, etc.)
- Do not use this unit in place where there is flammable or explosive gas.**  
It may cause a fire or explosion.
- Please observe the rated specifications.**  
It may shorten the life cycle or damage to the product.
- Please observe the rated voltage and do not supply AC power.**  
It may cause damage to this unit.
- Please check the polarity of power and wrong wiring.**  
It may cause damage to this unit.
- Do not use this unit in place where there is vibration or impact.**  
It may cause damage to this unit.
- In cleaning the unit, do not use water or an oil-based detergent.**  
It may cause electric shock or fire.

### Ordering information

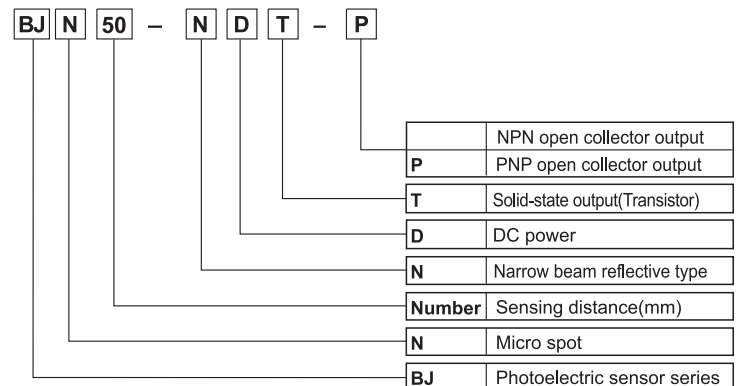

※The above specifications are subject to change and some models may be discontinued without notice.

### Dimensions

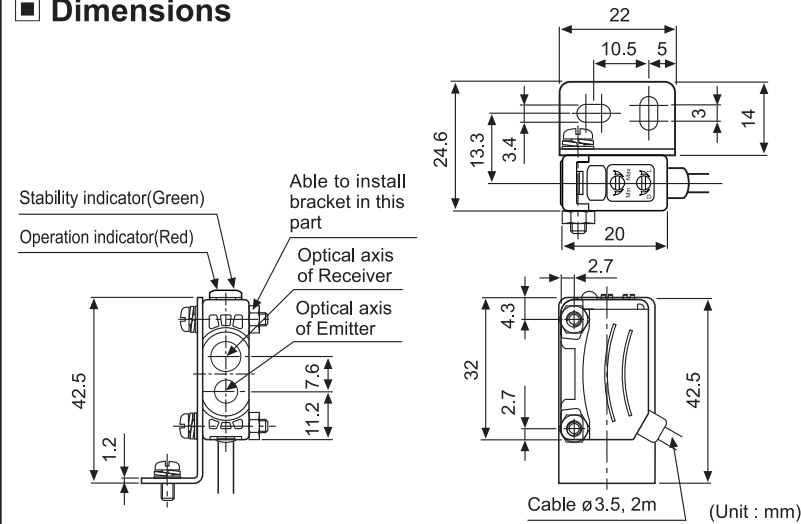

### Specifications

Sensing type	NPN output PNP output	Narrow beam reflective type <b>BJN50-NDT</b> <b>BJN50-NDT-P</b>	<b>BJN100-NDT</b> <b>BJN100-NDT-P</b>
Power supply	12-24VDC ±10%(Ripple P-P: Max.10%)		
Current consumption	Max. 30mA		
Min.diameter of transmitting SPOT	Approx. ø2.0mm	Approx. ø2.5mm	
Min.sensing target	Approx. min. ø 0.2mm(Copper wire)		
Sensing target	Translucent, Opaque materials		
Sensing distance	30 to 70mm (100×100mm Non-glossy white paper)	70 to 130mm (100×100mm Non-glossy white paper)	
Hysteresis	Max. 25% at sensing distance		Max. 20% at sensing distance
Light source/Wavelength	Red LED(650nm)		
Control output	NPN or PNP open collector output • Load voltage: Max. 26.4VDC • Load current: Max. 100mA • Residual voltage - NPN: Max. 1V, PNP : Max. 2.5V		
Operation mode	Light ON / Dark ON selectable(Short rotator adjuster)		
Protection circuit	Reverse polarity protection, Output short-circuit protection, Interference prevention function		
Response time	Max. 1ms		
Sensitivity adjustment	Built-in VR		
Environment	Ambient illumination	Sunlight: Max. 11,000lx, Incandescent lamp: Max. 3,000lx(Receiver illumination)	
	Ambient temperature	-25 to 55°C, Storage: -40 to 70°C	
	Ambient humidity	35 to 85%RH, Storage: 35 to 85%RH	
Insulation resistance	Min. 20MΩ (500VDC megger)		
Dielectric strength	1,000VAC 50/60Hz for 1minute		
Vibration	1.5mm or 300mm amplitude at frequency of 10 to 55Hz in each of X, Y, Z directions for 2 hours		
Shock	500m/s <sup>2</sup> X, Y, Z directions for 3 times		
Protection	IP65(IEC standard)		
Indicator	Operation indicator: Red, Stability indicator: Green		
Material	Case: PC+ABS, Sensing part: PMMA, LED CAP: PC		
Cable	ø3.5mm, 3-wire, Length: 2m(AWG24, Core diameter: 0.08mm, Number of cores: 40, Insulator diameter: ø 1mm)		
Accessory	Mounting bracket, Bolt, VR adjustment driver		
Approval	CE		
Unit weight	Approx. 45g		

※The temperature or humidity mentioned in Environment indicates a non freezing or condensation environment.

### Control output diagram

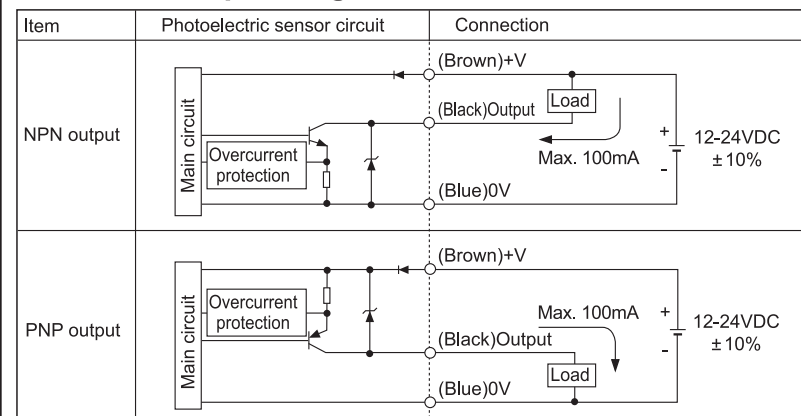

### Connections

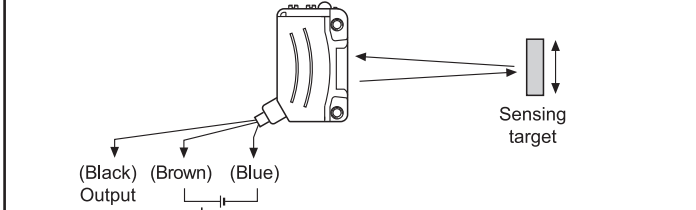

### Operation mode

Operation mode	Light ON	Dark ON
Receiver	Received light Interrupted light	High Low
Operation indicator (Red LED)	ON OFF	ON OFF
Transistor output	ON OFF	ON OFF

### Operation mode and timing diagram

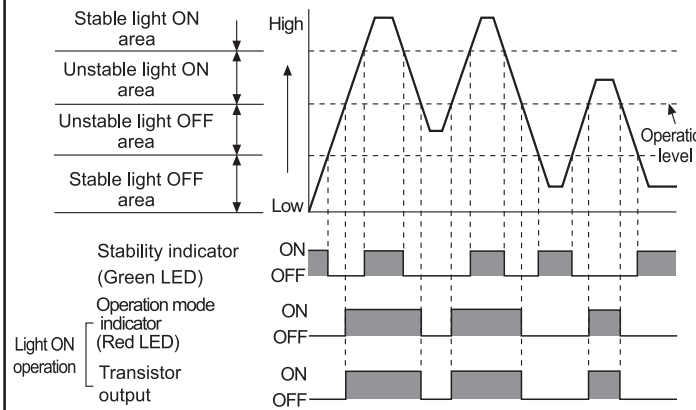

※The waveform of "Operation mode indicator" and "Transistor output" is for Light ON, it is operated as reverse in Dark ON.

### Mounting and sensitivity adjustment

- **For mounting**  
Please use M3 screw for mounting of sensor, set the tightening torque under 0.5N·m.
- **Switching of operation mode**

Light ON		Turn the operation switching adjuster to right(L direction), it is set as Light ON.
Dark ON		Turn the operation switching adjuster to left (D direction), it is set as Dark ON.

### Optical axis adjustment

After place a sensing target, fix it in the middle of position where the indicator is operated adjusting the sensor to up or down, left or right.

### Object(Copper wire) detection

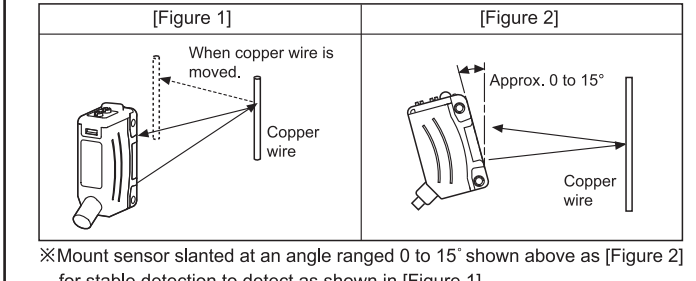

※Mount sensor slanted at an angle ranged 0 to 15° shown above as [Figure 2] for stable detection to detect as shown in [Figure 1].

### Sensitivity adjustment

Order	Sensitivity adjuster	Description
1		Turn the sensitivity adjuster to the right of min. and check position(A) where the indicator is turned on in "Light ON status".
2		Turn the sensitivity adjuster more to the right of position(A), check position(B) where the indicator is turned on. And turn the adjuster to the left, check position(C) where the indicator is turned off in "Light OFF status". ※If the indicator is not lighted although the adjuster is turned to the max. position, the max. position is(C).
3		Set the adjuster at the center of (A) and (C). To set the optimum sensitivity, check the operation and lighting of stable indicator with sensing target or without it. If the indicator is not lighted, please check the sensing method again because sensitivity is unstable.

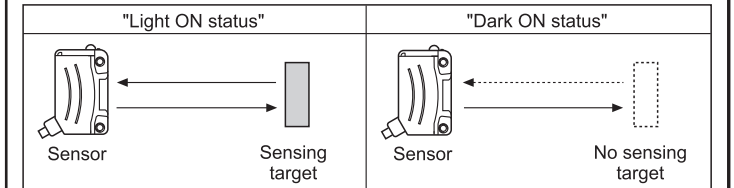

※Set the sensitivity to operate in a stable light ON area, the reliability for the environment (temperature, voltage, dust etc) will be increased.  
※Do not apply an excessive force on adjuster, it can be broken.

### Caution for using

- The sensor will be in a detectable status within 500ms after supply the power. If the power line of the load and the sensor is different, supply power voltage to the sensor first.
- Shade a strong source of light as like sunlight, spotlight not to be let in the inclination angle range of photoelectric sensor directly.
- The photoelectric sensor may cause malfunction under the fluorescent lamp light, be sure to use the cover or the shutter to shade the light.
- If photoelectric sensor is installed at flat part, it may cause malfunction by reflection light from flat part. Be sure to put space between photoelectric sensor and ground.
- When wiring the photoelectric sensor with high voltage line, power line in a same conduit, it may cause malfunction or mechanical problem, please do wire separately or use different conduit.
- Avoid install the unit in place with corrosive gas, oil or dust, strong flux, noise, sunlight, strong alkali and acid.
- In case of connecting relay as inductive load to output, please remove surge by using diode or varistor.
- Photoelectric sensor cable shall be used as short as possible, because it may cause malfunction by noise through the cable.
- When it is stained by dirt at lens, please clean the lens with dry cloth, do not use an organic materials such as alkali, acid and chromic acid.
- When use switching power supply as the source of supplying power, F.G. terminal shall be grounded and a condenser for removing noise shall be installed between 0V and F.G. terminal.

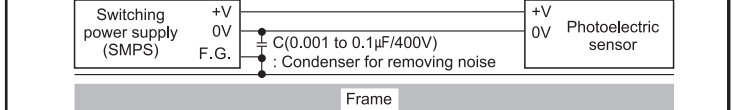

- Installation environment
  - ① It shall be used indoor
  - ② Altitude Max. 2,000m
  - ③ Pollution Degree 3

※It may cause malfunction if above instructions are not followed.

### Major products

- Photoelectric sensors
- Fiber optic sensors
- Door sensors
- Door side sensors
- Area sensors
- Proximity sensors
- Pressure sensors
- Rotary encoders
- Connector/Sockets
- Switching mode power supplies
- Control switches/Lamps/Buzzers
- I/O Terminal Blocks & Cables
- Stepper motors/drivers/motion controllers
- Graphic/Logic panels
- Field network devices
- Laser marking system(Fiber, CO<sub>2</sub>, Nd:YAG)
- Laser welding/soldering system
- Temperature controllers
- Temperature/Humidity transducers
- SSR/Power controllers
- Counters
- Timers
- Panel meters
- Tachometer/Pulse(Rate)meters
- Display units
- Sensor controllers

**Autonics Corporation**  
http://www.autonics.com

Satisfiable Partner For Factory Automation

HEAD QUARTERS:  
18, Bamsong-ro 513beon-gil, Haeundae-gu, Busan, Korea

OVERSEAS SALES:  
#402-404, Bucheon Techno Park, 655, Pyeongcheon-ro, Wiumi-gu, Bucheon, Gyeonggi-do, Korea  
TEL: 82-32-610-2700 / FAX: 82-32-329-9728  
E-mail: sales@autonics.com