

BMS Series

High speed response type with built-in output protection circuit

■ Features

- Reverse power polarity and overcurrent
- High speed response : Max. 1ms
- Light ON/Dark ON mode selectable by control wire
- Built-in the sensitivity adjustment VR (Except for through-beam type)

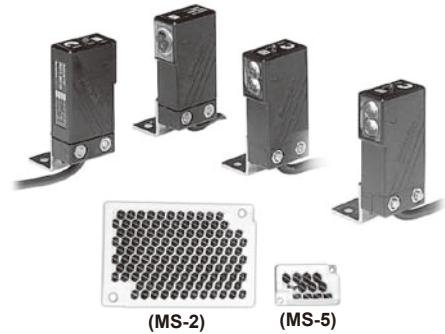

⚠ Please read "Caution for your safety" in operation manual before using.



(MS-2)

(MS-5)

※MS-5 is sold separately.

■ Specifications

Model	NPN open collector output	BMS5M-TDT	BMS2M-MDT	BMS300-DDT
	PNP open collector output	BMS5M-TDT-P	BMS2M-MDT-P	BMS300-DDT-P
Sensing type		Through-beam	Retroreflective	Diffuse reflective
Sensing distance		5m	0.1 to 2m ^{※1}	300mm ^{※2}
Sensing target		Opaque materials of Min. ϕ 10mm	Opaque materials of Min. ϕ 60mm	Translucent, Opaque materials
Hysteresis		—		Max. 20% at rated setting distance
Response time		Max. 1ms		
Power supply		12-24VDC \pm 10%(Ripple P-P : Max. 10%)		
Current consumption		Max. 50mA	Max. 45mA	
Light source		Infrared LED(940nm)		
Sensitivity adjustment		—		Adjustable VR
Response time		Selectable Light ON or Dark ON by control wire		
Control output		NPN or PNP open collector output ●Load voltage : Max. 30VDC ●Load current : Max. 200mA ●Residual voltage - NPN : Max. 1V, PNP : Max. 2.5V		
Protection circuit		Reverse power polarity, Output short-circuit(Overcurrent) protection circuit		
Indicator		Operation indicator : red LED, Power indicator : red LED(BMS5M-TDT1)		
Insulation resistance		Min. 20M Ω (at 500VDC megger)		
Noise resistance		\pm 240V the square wave noise(pulse width : 1 μ s) by the noise simulator		
Dielectric strength		1000VAC 50/60Hz for 1minute		
Vibration		1.5mm amplitude or 300m/s ² at frequency of 10 to 55Hz(for 1 min.) in each of X, Y, Z directions for 2 hours		
Shock		500m/s ² (approx. 50G) in each of X, Y, Z directions for 3 times		
Environment	Ambient illumination	Sunlight : Max. 11,000lx, Incandescent lamp : Max. 3,000lx		
	Ambient temperature	-10 to 60°C, storage : -25 to 70°C		
	Ambient humidity	35 to 85%RH, storage : 35 to 85%RH		
Material		Case : ABS, Sensing part : Acryl (Through-beam : PC)		
Cable		ϕ 5, 4-wire, Length : 2m(Emitter of through-beam type: ϕ 5, 2-wire, Length : 2m) (AWG22, Core diameter : 0.08mm, Number of cores : 60, Insulator out diameter : ϕ 1.25)		
Accessories	Individual	—	Reflector(MS-2), VR adjustment driver	VR adjustment driver
	Common	Mounting bracket, Bolts/nuts		
Approval		CE		
Unit weight		Approx. 180g	Approx. 110g	Approx. 100g

※1: It is mounting distance between sensor and reflector MS-2 and it is same when MS-5 is used. It is detectable under 0.1m.

※2: It is for Non-glossy white paper(100×100mm)

※The temperature or humidity mentioned in Environment indicates a non freezing or condensation environment.

Amplifier Built-in type by Side Sensing

■ Feature data

◎ Through-beam type

● BMS5M-TDT ● BMS5M-TDT-P

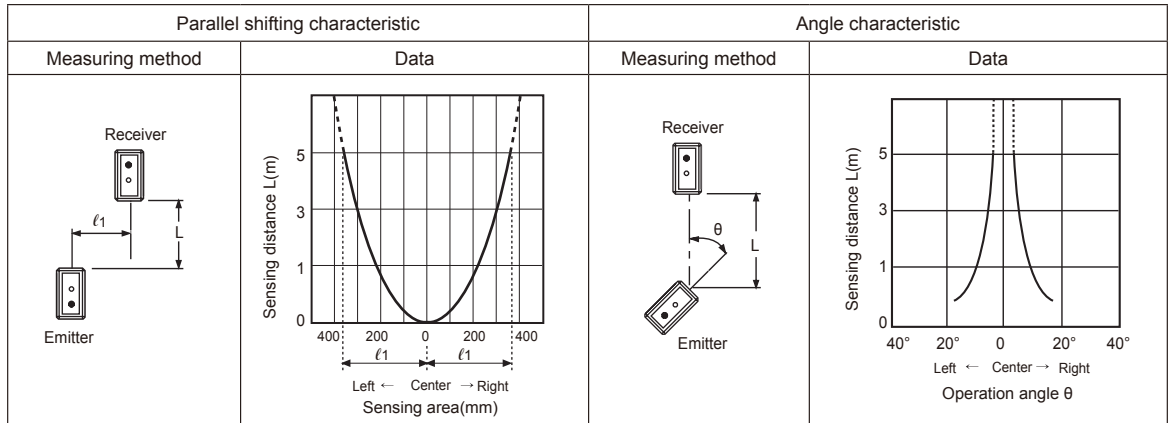

◎ Retroreflective type

● BMS2M-MDT ● BMS2M-MDT-P

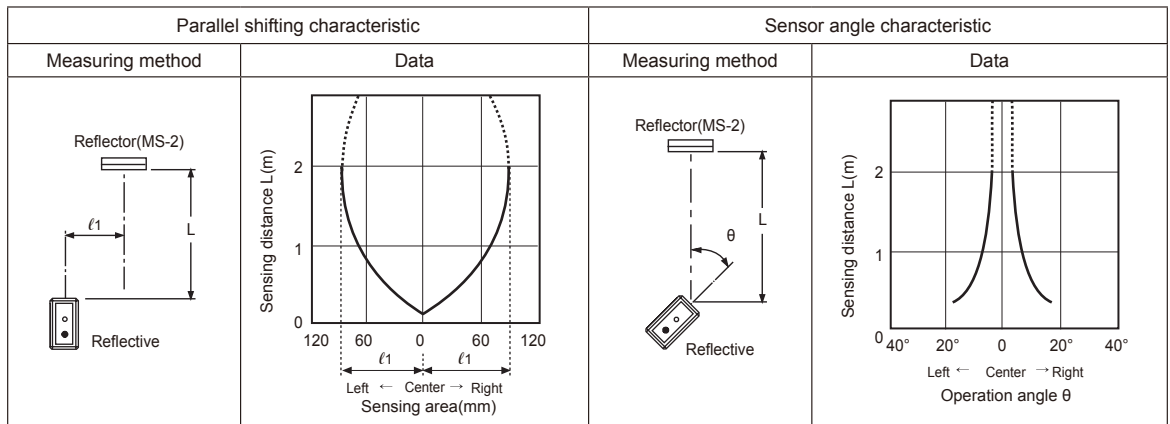

◎ Retroreflective type

● BMS2M-MDT ● BMS2M-MDT-P

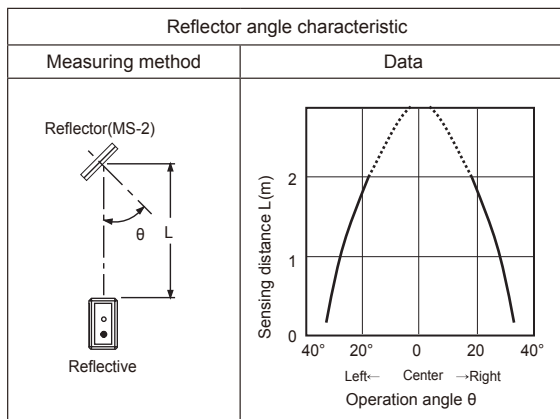

◎ Diffuse reflective type

● BMS300-DDT ● BMS300-DDT-P

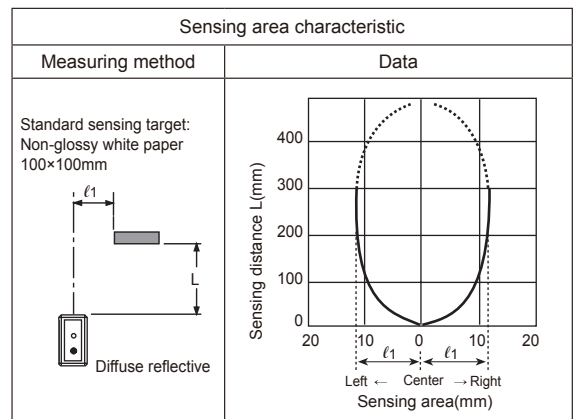

(A) Photo electric sensor

(B) Fiber optic sensor

(C) Door/Area sensor

(D) Proximity sensor

(E) Pressure sensor

(F) Rotary encoder

(G) Connector/Socket

(H) Temp. controller

(I) SSR/Power controller

(J) Counter

(K) Timer

(L) Panel meter

(M) Tacho/Speed/Pulse meter

(N) Display unit

(O) Sensor controller

(P) Switching mode power supply

(Q) Stepper motor& Driver&Controller

(R) Graphic/Logic panel

(S) Field network device

(T) Software

(U) Other

BMS Series

Control output diagram

NPN open collector output

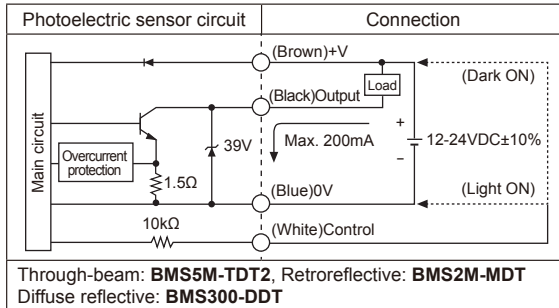

PNP open collector output

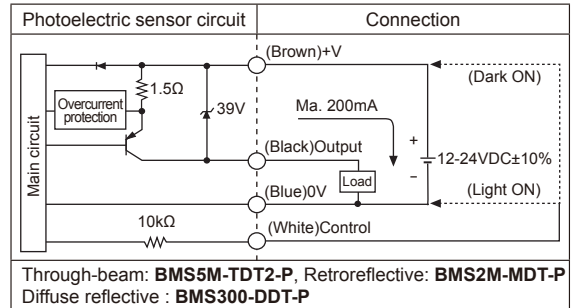

※Select Light ON / Dark ON by control wire. - Light ON : Connect control wire to 0V / Dark ON : Connect control wire to +V

Operation mode

Operation mode	Light ON	Dark ON
Receiver operation	Received light Interrupted light	Received light Interrupted light
Operation indicator (red LED)	ON OFF	ON OFF
Transistor output	ON OFF	ON OFF

Connections

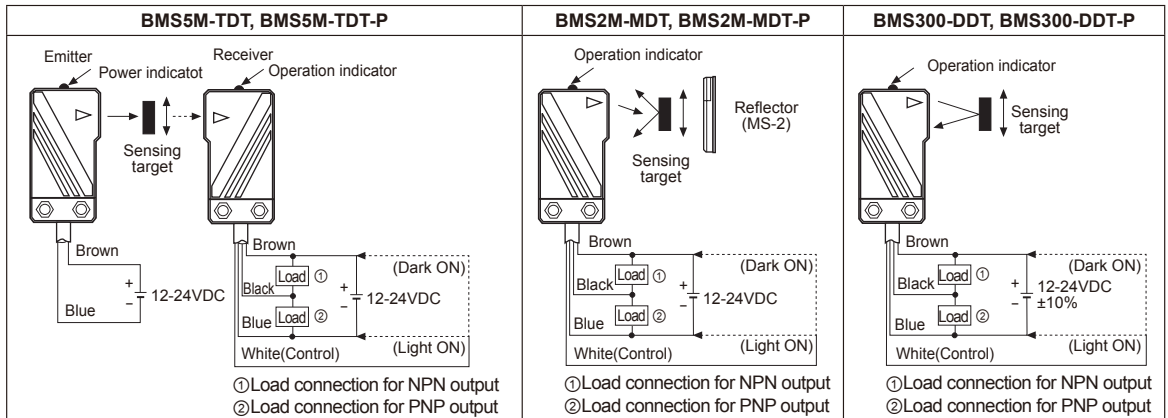

※Dark ON mode is on when control line is opened.

Dimensions

(unit: mm)

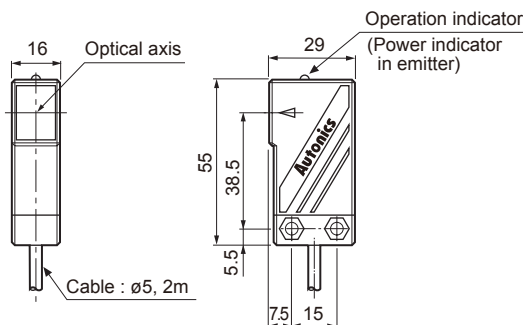

Connect the bracket

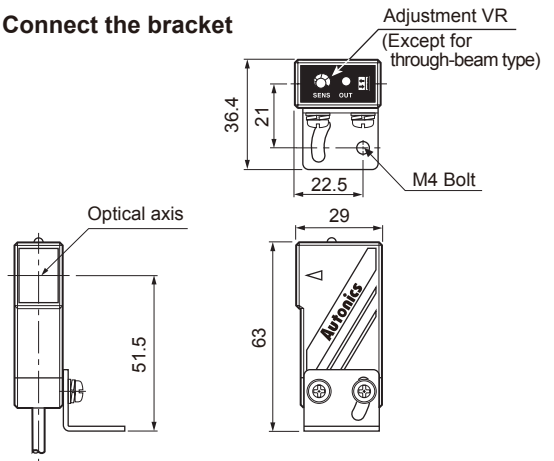

Amplifier Built-in type by Side Sensing

● Reflector

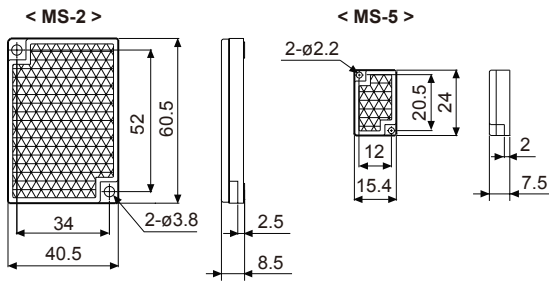

● Bracket

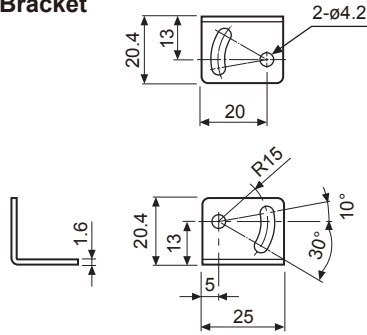

■ Mounting and sensitivity adjustment

Install the sensor to the desired place and check the connections.
Supply the power to the sensor and adjust the optical axis and the sensitivity as follow ;

◎ Optical axis adjustment

● Through-beam type

Set the photoelectric sensor in the middle of the operation range of the operation indicator adjusting the receiver or emitter right and left, up and down.

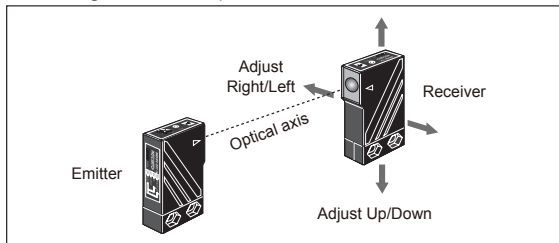

● Retroreflective type

Mount the photoelectric sensor and the reflector face each other then fix them in the middle of operation range of the operation indicator adjusting the reflector right and left, up and down.

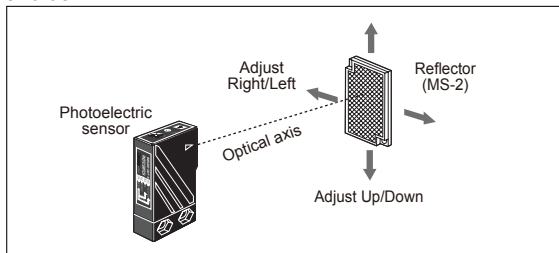

● Diffuse reflective type

Mount the photoelectric sensor and the target then fix them in the middle of operation range of the operation indicator adjusting the photoelectric sensor right and left, up and down.

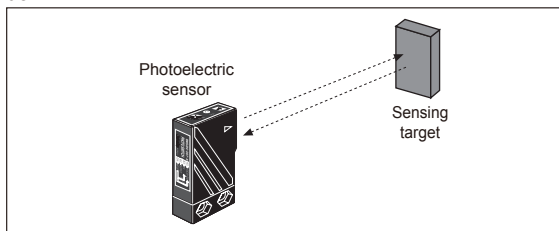

◎ Sensitivity adjustment

● Retroreflective type

Fix the adjustment VR at max.position and then check if the sensor operates normally to pass the target within sensing area of the sensor.
If the sensor does not work normally by noise or external shine, turn the adjustment VR slowly up to the position.

※If reflectance of target is higher than non-glossy white paper, it might cause malfunction by reflection from the target when the target is near to the photoelectric sensor. Therefore enough space between the target should be used and the photoelectric sensor or the surface of the target should be mounted at angle of 30° to 45° against optical axis.

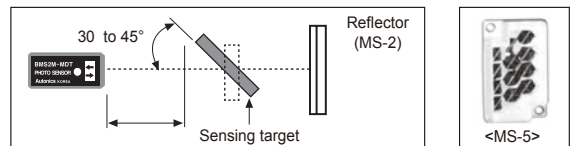

※If the mounting place is too narrow, please use MS-5 instead of MS-2.

● Diffuse reflective type

Set the target at a position to be detected by the beam, then turn the adjustment VR until position ㊸ where the operation indicator turns ON from min. position of the adjustment VR up to position ㊹ which the operation indicator turn ON from min.

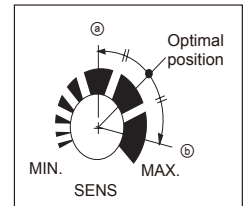

Take the target out of the sensing area, then turn the adjustment VR until position where the indicator turns ON. If position ㊸ is not checked, the max.position is ㊹. Set the adjustment VR in the middle of two switching position ㊸, ㊹.
※Please be aware not to make the unstable operation of sensor by background and mounting side.

(A)	Photo electric sensor
(B)	Fiber optic sensor
(C)	Door/Area sensor
(D)	Proximity sensor
(E)	Pressure sensor
(F)	Rotary encoder
(G)	Connector/ Socket
(H)	Temp. controller
(I)	SSR/ Power controller
(J)	Counter
(K)	Timer
(L)	Panel meter
(M)	Tacho/ Speed/ Pulse meter
(N)	Display unit
(O)	Sensor controller
(P)	Switching mode power supply
(Q)	Stepper motor& Driver&Controller
(R)	Graphic/ Logic panel
(S)	Field network device
(T)	Software
(U)	Other