

# KT-502H

## Features

- HART protocol
- 330° rotatable display for environment conditions
- 4-20mA analog output (2-wire)
- Various input (order 1 input type among 22 types)  
RTD: 8 types, Thermocouple: 8 types,  
mV: 4 types, Ω: 2 types
- Backlight helps to read easily in the darkness
- Explosion class : Ex d IIC T6 IP67



Please read "Caution for your safety" in operation manual before using this unit.



## Ordering information

KT — 502H 0 (-270 to 1372, K) \*1

① ②

Item	Description
① Mounting bracket	0 Without bracket 1 With bracket
② User temperature range	* 1: To order this unit, write the temperature sensor type and the temperature range.

## Specifications

Model	KT-502H	
Power supply	10.5-45VDC (with backlight LCD)	
Display method	PV display part : 7 Segment 5 digit (character size : W4×H8mm) Parameter display part : 14 Segment 8 digit (character size : W2.6×H4.8mm) 52 Bar meter	
Display range	-19999 to 99999	
Setting method	HART-protocol (no setting key)	
Response time	1 sec.	
Input type	RTD	DPt100Ω, DPt500Ω, DPt1000Ω, Ni100Ω, Ni500Ω, Ni1000Ω, Cu50Ω, Cu100Ω
	Thermocouple	K, J, T, E, N, S, B, R
	Resistance transmission(Ω)	0 to 400Ω, 0 to 2000Ω
	Voltage transmission(mV)	-10-75mV, -100-100mV, -100-500mV, -100-2000mV
Output	4-20mA(2-wire)	
Alarm	Below 3.8mA, Over 20.5mA Sensor break 3.6mA	
Load	max.(V power supply - 7.5V)/0.22A	
Galvanic insulation	2KVAC(input/output)	
Environment	Ambient temperature	-20 to 70°C, storage: 20 to 80°C
	Ambient humidity	0 to 85%RH
Explosion class*1	Ex d IIC T6 IP67	
Material	Body : Aluminum(AIDc.8S), Cover O-Ring : Buna N	
Unit weight	Approx. 1.2kg	

\*1: This Explosion class is acquired and managed by Konics Co., Ltd.

\*Environment resistance is rated at no freezing or condensation.

# Intelligent Temperature Transmitter

## Dimensions

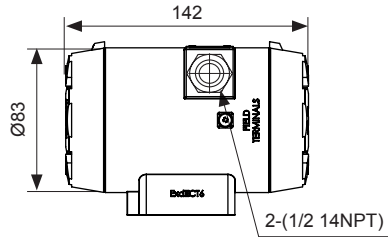
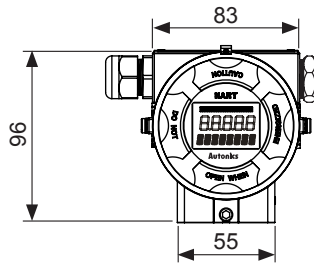

(unit: mm)

### • Mounting bracket

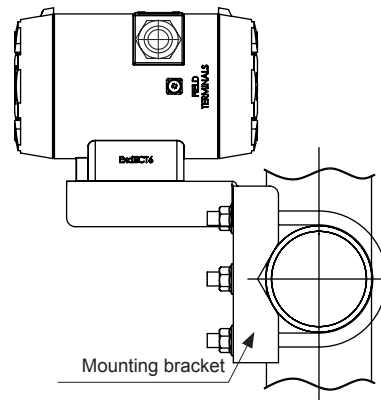
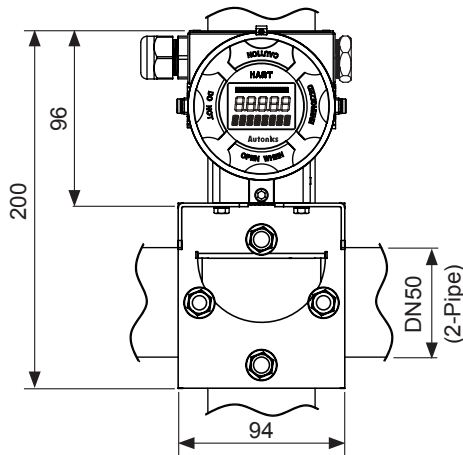

- A. Recorder
- B. Indicator
- C. Converter
- D. Controller
- E. Thyristor unit
- F. Pressure transmitter
- G. Temp. transmitter
- H. Accessories

## Input type and range

Input type		Input range(°C)	Input range(°F)
RTD	DPt100Ω	-200 to 850	-328 to 1562
	DPt500Ω	-200 to 250	-328 to 482
	DPt1000Ω	-200 to 250	-328 to 482
	Cu50Ω	-50 to 150	-58 to 302
	Cu100Ω	-50 to 150	-58 to 302
	Ni100Ω	-60 to 180	-76 to 356
	Ni500Ω	-60 to 180	-76 to 356
	Ni1000Ω	-60 to 150	-76 to 302
Resistance (Resistance transmitter)	Resistance (Ω)	0 to 400Ω	
		0 to 2000Ω	
Thermocouple	B (PtRh30-PtRh6)	0 to 1820	32 to 3308
	E(NiCr-CuNi)	-270 to 1000	-454 to 1832
	J(Fe-CuNi)	-210 to 1200	-346 to 2192
	K(NiCr-Ni)	-270 to 1372	-454 to 2501
	N(NiCrSi-NiSi)	-270 to 1300	-454 to 2372
	R(PtRh13-Pt)	-50 to 1768	-58 to 3214.4
	S(PtRh10-Pt)	-50 to 1768	-58 to 3214.4
	T(Cu-CuNi)	-270 to 400	-454 to 752
Analog	Voltage	-10 - 75mV	
		-100 - 100mV	
		-100 - 500mV	
		-100 - 2000mV	

## Connections

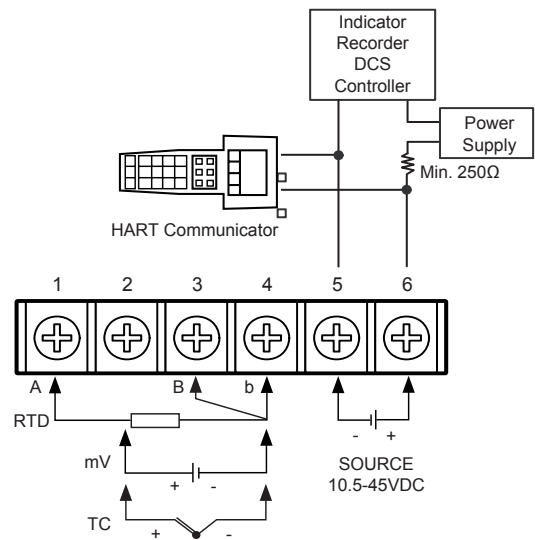

### • Opening cover

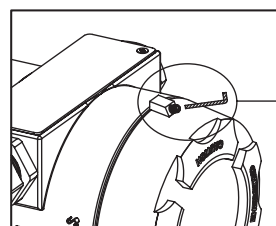

To open the cover, unscrew the M3 X 6L headless bolt using a 1.5 hexagon wrench and rotate the cover.

KT-502H

# KT-502H

## Current Trim adjustment

Connect a HART communicator and adjust current trim as below by a HART communicator.

- ① Select the '1. Device Setup' by ↑, ↓ keys and press the  key.

```
1. Device Setup
2. PV
3. PV Ao
4. PV LRV
5. URV
```

- ② Select the '2. Diag/Service' by ↑, ↓ keys and press the  key.

```
1. Process Variables
2. Diag/Service
3. Basic Setup
4. Detailed Setup
5. Review
```

- ③ Select the '4. D/A trim' by ↑, ↓ keys and press the  key.

```
1. Test device
2. Loop test
3. Calibration
4. D/A trim
```

- ④ Press the  (F4) key.

```
WARN-Loop should be
removed from
automatic control
  ABORT  OK
```

- ⑤ Press the  (F4) key.



```
Connect reference
meter
  ABORT  OK
```

- ⑥ Press the  (F4) key.

```
Setting fid dev
output to 4mA
  ABORT  OK
```

- ⑦ Press the  (F4) key to set 4 mA display value.

```
Enter meter Value
4.000
  HELP  DEL  ABORT  ENTER
```

- ⑧ If output display value is correct, select '1. Yes' and press the  (F4) key. If not, select '2. No' and press the  (F4) key and re-set the display value.

Ex) If output display value is 3.89mA, select 3.89 and press the  (F4) key.



```
Fid dev output 4.000
mA equal to reference
meter ?
1. Yes
2. No  ABORT  ENTER
```

- ⑨ Press the  (F4) key.

```
Setting fid dev.
output to 20mA
  ABORT  OK
```

- ⑩ Press the  (F4) key to set 20 mA display value.

```
Enter meter Value
20.000
  HELP  DEL  ABORT  ENTER
```

- ⑪ If output display value is correct, select '1. Yes' and press the  (F4) key. If not, select '2. No' and press the  (F4) key and re-set the display value.

```
Fid dev output 20.000
mA equal to reference
meter ?
1. Yes
2. No  ABORT  ENTER
```

- ⑫ Press the  (F4) key.

```
NOTE-Loop may be
returned to automatic
control
  ABORT  OK
```

- ⑬ Press the  (F3) key.

```
Diag/Service
1. Test device
2. Loop test
3. Calibration
4. D/A trim
  HELP  SAVE  HOME
```

- ⑭ Press the  (F3) key.

```
Device Disconnected
  RETRY  QUIT
```

- ⑮ Press the  (F3) key to complete the adjustment.

```
1. Offline
2. Online
3. Frequency Device
4. Utility
```

# Intelligent Temperature Transmitter

## Temperature range setting

① Press the  key for 3 sec.

Select the '4. PV LRV' by ↑, ↓ keys and press the  key.

```

Online (Generic)
1. Device Setup
2. PV
3. PV Ao
4. PV LRV
5. URV          SAVE
    
```

② Select '1. PV LRV'(Low temperature range) and press the  key.

```

1. PV LRV
2. URV
HELP  HOME
    
```

③ Set Low temperature range and press the **ENTER** (F4) key.

```

PV LRV
0.000 deg C
0.000
HELP  DEL  ESC  ENTER
    
```

④ Select '2. URV'(High temperature range) and press the  key.

```

1. PV LRV
2. URV
HELP  HOME
    
```

⑤ Set High temperature range and press the **ENTER** (F4) key.

```

PV URV
100.000 deg C
100.000
HELP  DEL  ESC  ENTER
    
```

⑥ When the set temperature range is correct, press the **SEND** (F2) key.

```

1. PV LRV 0.000 deg C
2. URV 100.000 deg C
HELP  SEND  HOME
    
```

⑦ Press the **OK** (F4) key.

```

- WARNING -
Pressing ' OK ' will
change device output
put 100P in manual
    
```

⑧ Press the **OK** (F4) key.

```

- WARNING -
Return control 100P
To automatic control
      OK
    
```

⑨ Check the set temperature range. Press the **HOME** (F3) key. HART communication is OFF.

```

1. PV LRV 0.000 deg C
2. URV 100.000 deg C
HELP  HOME
    
```

## Proper usage

### Caution for using

- For connecting the power, use a crimp terminal (M3.5, min. 7.2mm).
- The connection of this unit should be separated from the power line and high voltage line in order to prevent inductive noise.
- Install a power switch or a circuit breaker to supply or cut off the power.
- Switch or circuit breaker should be installed nearby users for convenient control.
- Do not use this unit near the high frequency instruments (high frequency welding machine & sewing machine, large capacity SCR controller).
- Installation environment.
  - ① Indoor / Outdoor
  - ② Altitude max. 2,000m
  - ③ Pollution degree 2
  - ④ Installation category II
- Use the verified explosion-proof electric connection (cable gland or sealing fitting) (over Ex d IIC T6 IP67).
- Use the dedicated external terminal for earth. For connecting earth, use a spring washer and earth cable which is over 4mm<sup>2</sup>.
- **We are not responsible for any damages and claims for careless. Must read the cautions for your safety and using.**
- **This explosion-proof unit is certified and the same specifications which is reported to Korea Gas Safety Corporation.**
- **If there are any problems with the unit, contact the sales office.**
- **It may cause malfunction if above instructions are not followed.**

A. Recorder

B. Indicator

C. Converter

D. Controller

E. Thyristor unit

F. Pressure transmitter

G. Temp. transmitter

H. Accessories

KT-502H