

# Autonics Multi-Channel Modular Type High Performance Temperature Controller [Option Module] TMHA/TMHE/TMHCT/TMHC Series

## INSTRUCTION MANUAL



Thank you for choosing our Autonics product. Please read the following safety considerations before use.

### Safety Considerations

- Please observe all safety considerations for safe and proper product operation to avoid hazards.
- Warning Failure to follow these instructions may result in serious injury or death.
- Caution Failure to follow these instructions may result in personal injury or product damage.
- Warning Failure to follow these instructions may result in fire.
- Fail-safe device must be installed when using the unit with machinery that may cause serious injury or substantial economic loss.
- Install on a device panel to use.
- Do not connect, repair, or inspect the unit while connected to a power source.
- Check 'Connections' before wiring.
- Do not disassemble or modify the unit.

### Caution

- When connecting the power input and relay output, use AWG 20 (0.50mm<sup>2</sup>) cable or over and tighten the terminal screw with a tightening torque of 0.74 to 0.90Nm.
- Use the unit within the rated specifications.
- Do not use the unit in the place where flammable/explosive/corrosive gas, humidity, direct sunlight, radiant heat, vibration, impact, or salinity may be present.
- Keep metal chip, dust, and wire residue from flowing into the unit.

### Ordering Information

Type	Analog input/output	Digital input, alarm output	CT input	RS422/RS485 communication output
Model	TMHA-42AE	TMHE-82RE	TMHCT-82NE	TMHC-22SE
Input	Temperature sensor/ Analog input 1 to 4	Digital input 1 to 8	CT input 1 to 8	—
Output	Transmission output (0/4-20mA) 1 to 4	Alarm output 1 to 8	—	COM1, COM2 output

### Comprehensive Device Management Program[DAQMaster]

DAQMaster is a comprehensive device management software for setting parameters and monitoring processes. DAQMaster can be downloaded from our website at [www.autonics.com](http://www.autonics.com).

Item	Minimum specifications
System	IBM PC compatible computer with Pentium III or above
Operations	Windows 98/NT/XP/Vista/7/8/10
Memory	256MB+
Hard disk	1GB+ of available hard disk space
VGA	Resolution: 1024x768 or higher
Others	RS232C serial port (9-pin), USB port

### Connections

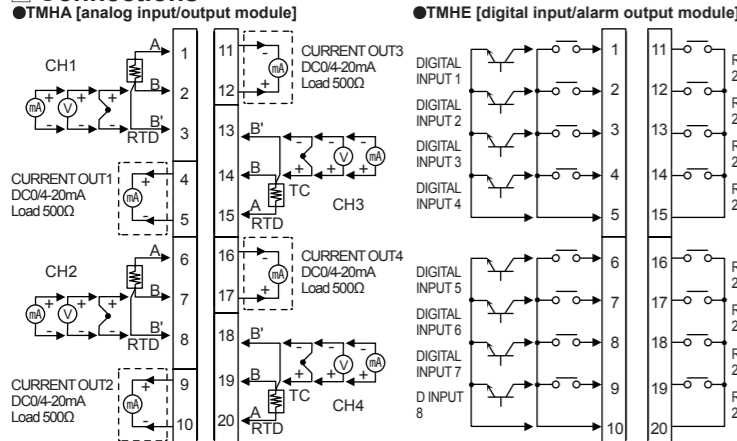

The above specifications are subject to change and some models may be discontinued without notice. Be sure to follow cautions written in the instruction manual, user manual and the technical descriptions (catalog, homepage).

### Specifications

Model	TMHA-42AE	TMHE-82RE	TMHCT-82NE	TMHC-22SE
No. of channels	4 channels	8 points	8 points	COM1, COM2
Power supply	24VDC			
Permissible voltage range	90 to 110% of rated voltage			
Power consumption	Max. 5W (for max. load)			
Display method	None- parameter setting and monitoring is available at external devices (PC, PLC, etc.)			
Input type	Thermocouple	RTD	Analog	Digital
	K(CA), J(IC), E(CR), T(CC), B(PR), R(PR), S(PR), N(NN), C(TT), G(TT), L(IC), U(CC), Platinum II	DP1100Ω, JPH100Ω, DP150Ω, Cu100Ω, Cu50Ω, Nickel 120Ω 3-wire type (permissible line resistance max. 5Ω per line)	• Voltage: 0-100mVDC, 0-5VDC, 1-5VDC, 0-10VDC • Current: 0-20mA, 4-20mA	• Connect input: ON - max. 1kΩ, OFF - min. 100kΩ • Solid-state input: ON - max. residual voltage 0.9V, OFF - max. leakage current 0.5mA • Outflow current: approx. 0.3mA per input
Sampling cycle	50ms (4CH synchronous sampling)			
Measured accuracy	At room temperature (23°C±5°C): (PV ±0.3% or ±1°C, higher one) ±1-digit	At room temperature (23°C±5°C): ±0.3% F.S. ±1-digit	—	±5% F.S. ±1-digit
	Out of room temperature range: (PV ±0.5% or ±2°C, higher one) ±1-digit	Out of room temperature range: ±0.5% F.S. ±1-digit	—	—
Alarm	—			250VAC~ 3A 1a
Transmission	DC 4-20mA or DC 0-20mA (load resistance max. 500Ω)			
Communication	Master	RS485 communication output (Modbus RTU)		
	PC loader	Serial (TTL Level), half duplex		
Mechanical	—		Min. 10,000,000 operations	—
	—		Min. 100,000 operations (250VAC 3A resistance load)	—
Electrical	—			
Memory retention	Approx. 10 years (non-volatile semiconductor memory type)			
Insulation resistance	Over 100MΩ (500VDC megger)			
Insulation type	Double insulation or reinforced insulation (mark:  dielectric strength between the measuring input part and the power part : 1kV)			
	Dielectric strength 1,000VAC 50/60Hz for 1 min (between power source terminal and input terminal)			
Vibration	0.75mm amplitude at frequency of 5 to 55Hz (for 1 min) in each X, Y, Z direction for 2 hours			
Noise immunity	Square shaped noise by noise simulator (pulse width 1μs) ±0.5kV R-phase, S-phase			
Environ. Ambient temp.	-10 to 50°C, storage: -20 to 60°C			
Ambient humi.	35 to 85%RH, storage: 35 to 85%RH			
Protection structure	IP20 (IEC standard)			
Accessories	Expansion connector: 1, module lock connector: 2			
Approval				
Weight	Approx. 233.8g (approx. 160.7g)	Approx. 239g (approx. 165.9g)	Approx. 220.6g (approx. 147.5g)	Approx. 222.1g (approx. 149.0g)

※1: Voltage of power supply/communication terminal placed in the backside of TMH2/4 Series (basic control module)  
 ※2: In case of TMHA, connecting 1 or more expansion module can vary measurement accuracy about ±1%, regardless of the number of connected expansion module.  
 ※3: At room temperature (23°C±5°C):  
 • Thermocouple K, J, N, E below -100°C, L, U, PLII and RTD Cu50Ω, DP150Ω:  
 (PV ±0.3% or ±2°C, higher one) ±1-digit  
 • Thermocouple C, G and S below 200°C: (PV ±0.3% or ±3°C, higher one) ±1-digit  
 • Thermocouple B below 400°C: there is no accuracy standards.  
 Out of room temperature range  
 • RTD Cu50Ω, DP150Ω: (PV ±0.5% or ±3°C, higher one) ±1-digit  
 • Thermocouple R, S, B, C, G: (PV ±0.5% or ±5°C, higher one) ±1-digit  
 • Others blow -100°C: within ±5°C  
 ※4: The weight includes packaging. The weight in parenthesis is for unit only.  
 ※Environment resistance is rated at no freezing or condensation.

### Manuels

For the detail information and instructions, please refer to user manual and user manual for communication, and be sure to follow cautions written in the technical descriptions (catalog, homepage). Visit our homepage ([www.autonics.com](http://www.autonics.com)) to download manuals.

### Error Display

Status	Input error
Indicator	—
PRW	ON (red)
CH <sup>n</sup>	Flash (red)

※1: Input error: input value is below the input range (LLLL) / input value exceeds input range (HHHH) / input sensor wire is down/input sensor is disconnected (OPEN).  
 ※2: An indicator of relative channel flashes. After main cause of the error is solved, error status is cleared and the device is returned to the normal operation automatically.

### Unit Description

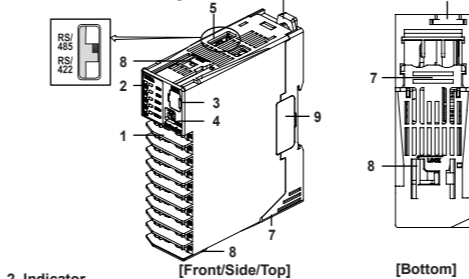

1. Input/Output terminal For specific information about terminal formation, please refer to 'Connections and Isolated Block Diagram'.

### Indicator

●TMHA [analog input/output module]

Indicator	Status	Initial power ON	Internal comm.	Transmission output
LED 1 LED 2	PWR (green)	ON	ON	ON
PWR	CH1 (red)	—	—	ON
	CH2 (red)	—	—	ON
	CH3 (red)	—	—	ON
	CH4 (red)	—	—	ON
CH	(yellow)	Flash (4,800bps)	Module comm. status	—
	(yellow)	Flash (9,600bps)	ON (CH1)	—
	(yellow)	Flash (19,200bps)	ON (CH2)	—
	(yellow)	Flash (38,400bps)	ON (CH3)	—
LED 2	(yellow)	Flash (115,200bps)	ON (CH4)	—

●TMHE [digital input, alarm output module]

Indicator	Status	Initial power ON	Internal comm.	Alarm output
LED 1 LED 2	PWR (green)	ON	ON	ON
PWR	CH1 (red)	—	—	OFF ON OFF ON
	CH2 (red)	—	—	OFF ON OFF ON
	CH3 (red)	—	—	OFF ON OFF ON
	CH4 (red)	—	—	OFF ON OFF ON
AL	(yellow)	Flash (4,800bps)	Module comm. status	Module comm. status
	(yellow)	Flash (9,600bps)	ON (CH1)	OFF ON OFF ON
	(yellow)	Flash (19,200bps)	ON (CH2)	OFF ON OFF ON
	(yellow)	Flash (38,400bps)	ON (CH3)	OFF ON OFF ON
LED 2	(yellow)	Flash (115,200bps)	ON (CH4)	OFF ON OFF ON

●TMHCT [CT input module]

Indicator	Status	Initial power ON	CT input	Internal comm.
LED 1 LED 2	PWR (green)	ON	ON	ON
PWR	(red)	—	ON (40.1 to 50.0A)	—
	(red)	—	ON (30.1 to 40.0A)	—
	(red)	—	ON (20.1 to 30.0A)	—
	(red)	—	ON (10.1 to 20.0A)	—
CT	(yellow)	Flash (4,800bps)	Module comm. status	Module comm. status
	(yellow)	Flash (9,600bps)	ON (40.1 to 50.0A)	—
	(yellow)	Flash (19,200bps)	ON (30.1 to 40.0A)	—
	(yellow)	Flash (38,400bps)	ON (20.1 to 30.0A)	—
LED 2	(yellow)	Flash (115,200bps)	ON (10.1 to 20.0A)	—

●TMHC [RS422/RS485 communication output module]

Indicator	Status	Initial power ON	Internal comm.	Connection
LED 1 LED 2	PWR (green)	Flash (4,800bps)	—	—
PWR	(red)	Flash (9,600bps)	Flash (TMH2/4)	—
	(red)	Flash (19,200bps)	Flash (TMHA)	—
	(red)	Flash (38,400bps)	Flash (TMHE)	—
	(red)	Flash (115,200bps)	Flash (TMHCT)	—
CT	(yellow)	Flash (4,800bps)	—	Module comm. status
	(yellow)	Flash (9,600bps)	—	ON (TMH2/4)
	(yellow)	Flash (19,200bps)	—	ON (TMHA)
	(yellow)	Flash (38,400bps)	—	ON (TMHE)
LED 2	(yellow)	Flash (115,200bps)	—	ON (TMHCT)

- ※1: At the moment when power is on, the indicator of set communication speed flashes for 5 sec.
- ※2: When communicating with external device, PWR indicator flashes.
- ※3: Displays internal communication status between modules.  
ON: normal / flash: abnormal / OFF: not communicating
- ※4: The indicator corresponding to the certain setting value of CT input flashes according to the parameter [CT Input Value Indication Lamp].  
LED 1: CT Input Value Indication Lamp / LED 2: CT Input Value Indication Lamp2
- ※5: At the moment when power is on, the indicator corresponding to host communication speed flashes for 5 sec.  
LED 1: host 1 / LED 2: host 2
- 3. PC loader port: PC loader port supports serial communication between single module and PC. It needs EXT-US (converter cable)+SCM-US (USB/Serial converter, sold separately) for communicating.
- 4. Communication address setting switch (SW1): Set the communication address.  
If changing the communication address by setting switch, use the flat head driver which is 2mm size or plastic driver. If not, it may cause product damage.
- 5. Communication mode switch (SW2): Select communication mode between RS485 and RS422. (TMHC only)
- 6. Rail lock: Rail lock helps installing the device to DIN rail or with bolts.
- 7. Lock lever: Lock lever holds module body and base tightly.
- 8. Module lock connector hole: When connect modules, insert module lock connector in the hole in order to enhance coherence between modules.
- 9. END cover: When connect modules, remove END cover in order to connect expansion connector.

### Communication Setting

It is for parameter setting and monitoring via external devices (PC, PLC, etc.). In case of TMHC, set COM1/2.

●Interface

Comm. protocol	Modbus RTU	Response waiting time	Comm. speed
Connection type	RS485, RS422 (RS422, TMHC only)	5 to 99ms (default: 20ms)	4800, 9600 (default), 19200, 38400, 115200 bps
Application standard	EIA RS485 Compliance with	Start bit	1-bit (fixed)
Max. connection	Each module 16 units	Data bit	8-bit (fixed)
Comm. method	Asynchronous	Parity bit	None (Default), Odd, Even
Comm. effective range	Two-wire half duplex	Stop bit	1-bit, 2-bit (default)
Comm. effective range	Max. 800m	—	—

●Communication address setting  
Set the communication address with the communication address setting switch (SW1). (default: [SW1] 1)

Series	SW1	0	1	2	3	4	5	6	7	8	9	A	B	C	D	E	F
TMHC		16	01	02	03	04	05	06	07	08	09	10	11	12	13	14	15
TMHA		48	33	34	35	36	37	38	39	40	41	42	43	44	45	46	47
TMHE		64	49	50	51	52	53	54	55	56	57	58	59	60	61	62	63
TMHCT		80	65	66	67	68	69	70	71	72	73	74	75	76	77	78	79

When using TMHC, in case connecting only TMHC to Master (PC, PLC, etc.), communication address of TMHC and TMH2/4 Series control module can be duplicated. However, in case connecting both TMHC and TMH2/4 Series control module to Master, communication address must not be duplicated. (If the TMHC and TMH modules communicate to Master at the same time, a communication error may occur.)

### Caution for communication address setting

After changing communication address via the power/comm. terminal, reboot the device.

### Installation

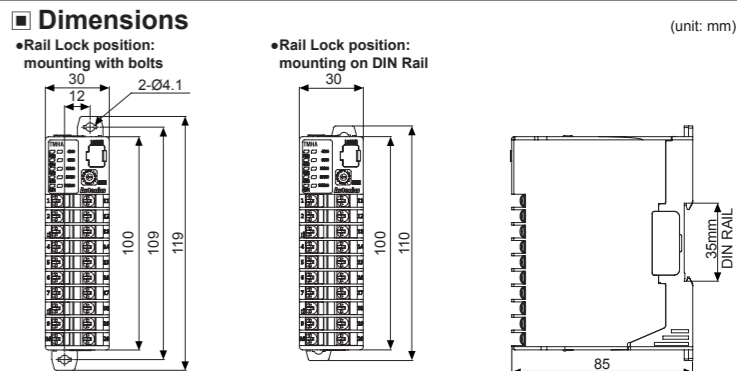
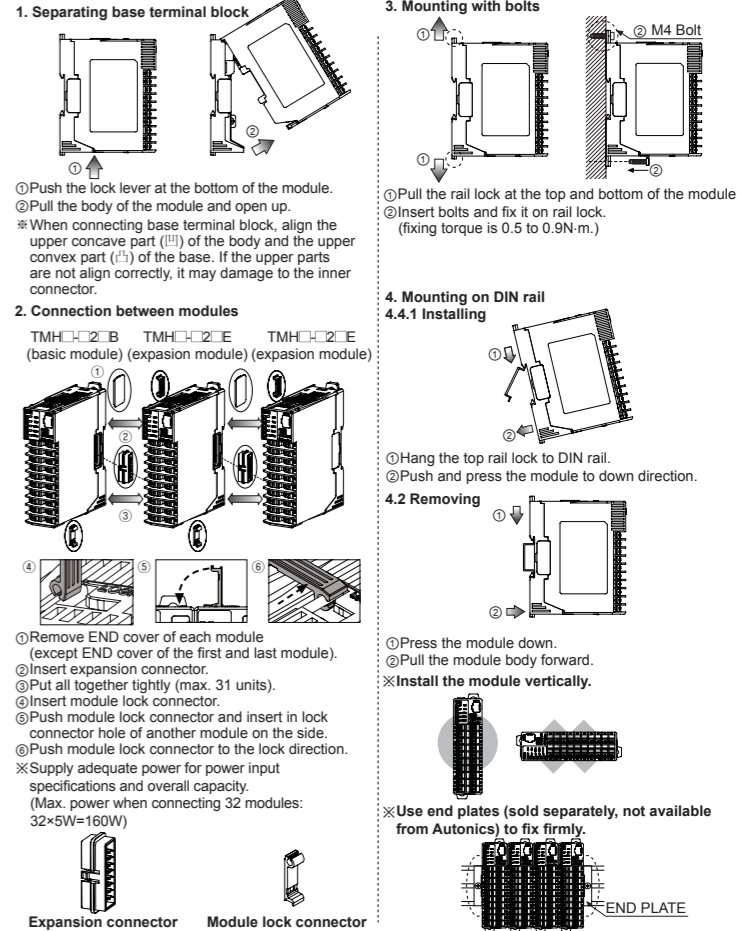

### Cautions during Use

- 1. Follow instructions in 'Cautions during Use'. Otherwise, it may cause unexpected accidents.
- 2. Do not connect the terminals before wiring the temperature sensor.
- 3. For RTD temperature sensor, wire it as 3-wire type, using cables in same thickness and length.
- 4. For thermocouple (CT) temperature sensor, use the designated compensation wire for extending wire.
- 3. Keep away from high voltage lines or power lines to prevent induction noise. In case installing power line and input signal line closely, use line filter or varistor at power line and shielded wire at input signal line.
- 4. Do not use near the equipment which generates strong magnetic force or high frequency noise.
- 4. Do not apply excessive power when connecting or disconnecting the connectors of the product.
- 5. Install a power switch or circuit breaker in the easily accessible place for supplying or disconnecting the power.
- 6. Do not use the unit for other purpose (e.g. voltmeter, ammeter), but temperature controller.
- 7. When changing the input sensor, turn off the power first before changing.
- 8. After changing the input sensor, modify the value of the corresponding parameter.
- 8. Power supply should be insulated and limited voltage/current or Class 2, SELV power supply device.
- 9. Do not overlapping communication line and power line.
- 9. Use twisted pair wire for communication line and connect ferrite bead at each end of line to reduce the effect of external noise.
- 10. Make a required space around the unit for radiation of heat.
- 11. For accurate temperature measurement, warm up the unit over 20 min after turning on the power.
- 11. Make sure that power supply voltage reaches to the rated voltage within 2 sec after supplying power.
- 12. Do not wire to terminals which are not used.
- 13. Install DIN rail vertically from the ground.
- 14. This unit may be used in the following environments.  
 ○Indoors (in the environment condition rated in 'Specifications')  
 ○Altitude max. 2,000m  
 ○Installation category II

### Major Products

- Photoelectric Sensors
- Fiber Optic Sensors
- Door Side Sensors
- Area Sensors
- Proximity Sensors
- Pressure Sensors
- Rotary Encoders
- Connector/Sockets
- Switching Mode Power Supplies
- Control Switches/Lamps/Buzzers
- I/O Terminal Blocks & Cables
- Stepper Motors/Drivers/Motion Controllers
- Graphic/Logic Panels
- Field Network Devices
- Laser Marking System (Fiber, Co., Nd:Yag)
- Laser Welding/Cutting System
- Temperature Controllers
- Temperature/Humidity Transducers
- SSR/Power Controllers
- Counters
- Timers
- Panel Meters
- Tachometer/Pulse (Rate) Meters
- Display Units
- Sensor Controllers

**Autonics Corporation**  
<http://www.autonics.com>  
**HEADQUARTERS:**  
 18, Bamsong-ro 513beon-gil, Haeundae-gu, Busan, South Korea, 48002  
 TEL: 82-51-519-3232  
 E-mail: [sales@autonics.com](mailto:sales@autonics.com)