

Autonics

**Pressure Transmitter
TPS20 SERIES**

INSTRUCTION MANUAL



Head type DIN connector type Connector cable type

Thank you for choosing Autonics product.
Please read the following safety considerations before use.

■ Safety Considerations

- ※ Please observe all safety considerations for safe and proper product operation to avoid hazards.
- ※ ⚠ symbol represents caution due to special circumstances in which hazards may occur.
- ⚠ Warning** Failure to follow these instructions may result in serious injury or death.
- ⚠ Caution** Failure to follow these instructions may result in personal injury or product damage.

⚠ Warning

1. **Fail-safe device must be installed when using the unit with machinery that may cause serious injury or substantial economic loss.** (e.g. nuclear power control, medical equipment, ships, vehicles, railways, aircraft, combustion apparatus, safety equipment, crime/disaster prevention devices, etc.)
Failure to follow this instruction may result in personal injury, fire, or economic loss.
2. **Do not use the unit where flammable or explosive gas, humidity, direct sunlight, radiant heat, vibration and impact may be present.**
Failure to follow this instruction may result in fire or explosion.
3. **Do not disassemble or modify the unit. Please contact us if necessary.**
Failure to follow this instruction may result in fire.

⚠ Caution

1. **Do not apply beyond rated pressure.**
Failure to follow this instruction may result in product damage.
2. **Use the unit within the rated specifications.**
Failure to follow this instruction may result in fire or shortening the life cycle of the unit.
3. **Fix the cable through the cable connection part.**
Do not turn the cable of the unit.
Failure to follow this instruction may result in product damage.
4. **Keep dust and wire residue from flowing into the unit.**
Failure to follow this instruction may result in burn out of the unit.
5. **Check the polarity of the measurement terminals before wiring the unit.**
Failure to follow this instruction may result in burn out of the unit.
6. **Please contact us for using the unit to the corrosive detergent.**
Failure to follow this instruction may result in shortening the life cycle of the unit or product damage.
7. **Do not use water or oil-based detergent when cleaning the unit. Use dry cloth to clean the unit.**
Failure to follow this instruction may result in or fire.

■ Connections

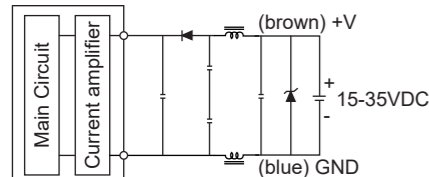

※ The above specifications are subject to change and some models may be discontinued without notice.

■ Ordering Information

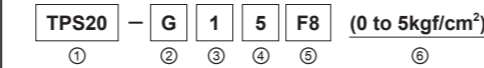

① Item	Description		
① Item	TPS20	Pressure Transmitter	
② Measurement pressure	G	Gauge pressure	
	A	Absolute pressure	
	1	Head type	
③ Cable	2	DIN connector type	
	3	Connector cable type	
		Gauge pressure	Absolute pressure
④ Pressure range	1	0 to 0.2kgf/cm ²	—
	2	0 to 0.5kgf/cm ²	—
	3	0 to 1kgf/cm ²	0 to 1kgf/cm ²
	4	0 to 2kgf/cm ²	0 to 2kgf/cm ²
	5	0 to 7kgf/cm ²	0 to 7kgf/cm ²
	6	0 to 10kgf/cm ²	0 to 10kgf/cm ²
	7	0 to 20kgf/cm ²	0 to 20kgf/cm ²
	8	0 to 35kgf/cm ²	0 to 35kgf/cm ²
	9	0 to 70kgf/cm ²	—
	A	0 to 100kgf/cm ²	—
	C	0 to 200kgf/cm ²	—
	F	0 to 300kgf/cm ²	—
	H	0 to 350kgf/cm ²	—
	O	-760mmHg to 0kgf/cm ²	—
	Q	-760mmHg to 1kgf/cm ²	—
	V	-760mmHg to 7kgf/cm ²	—
X	-760mmHg to 10kgf/cm ²	—	
Y	-760mmHg to 20kgf/cm ²	—	
Z	-760mmHg to 35kgf/cm ²	—	
Z	Others	—	
⑤ Pressure port	P2	PT 1/2 (with adapter)	—
	P8	PT 3/8 (with adapter)	—
	F8	PF 3/8 (Standard)	—
	ZZ	Others	—
⑥ User pressure range	User pressure range ^{*1}		

※ 1: Write the desired pressure range and it is the default of user pressure range. (Select "Z" at ④ Pressure range)
※ For ordering cable, order as CID3-2, CID3-5, CLD3-2, CLD3-5. (Sold separately)

■ Specifications

Series	TPS20		
Pressure type	Gauge pressure	Absolute pressure	Compound pressure
Rated pressure range	0 to 0.2 to 350 kg/cm ²	0 to 1.0 to 35 kg/cm ²	-760 mmHg to 0 to 30 kg/cm ²
Max. pressure range	300% of max. span		
Measured materials	Liquid, Gas, Oil (except corrosive environment of Stainless steel type 316)		
Power supply	15-35VDC=		
Permissible voltage range	90 to 110% of rated voltage		
Current consumption	Max. 50mA		
Response time	Max. 100 ms		
Protection circuit	Reverse polarity protection circuit		
Current output	DC4-20 mA		
Linearity	±0.3% F.S. (-10 to 50 °C), ±0.5% F.S. (50 to 70 °C)		
Hysteresis	±0.3% F.S.		
Temp. Zero Shift	±0.03% F.S.		
Temp. Span Shift	±0.03% F.S. (at 25 °C)		
Load resistance	Max. 600 Ω		
Insulation resistance	Over 100MΩ (at 500VDC megger)		
Dielectric strength	500VAC 50/60Hz for 1 minute		
Vibration	1.5mm amplitude at frequency of 10 to 55Hz (for 1 min) in each X, Y, Z direction for 2hours		
Shock	95m/s ²		
Tightening torque	Industrial plug over 5N		
Pressure port	PF 3/8(standard), PT 3/8, PT 1/2		
Environment	Ambient temp.	-10 to 70 °C, storage: -10 to 70 °C	
	Ambient humid.	5 to 95% RH, storage: 5 to 95% RH	
Materials	Sealing, Diaphragm, Connection: Stainless steel type 316, O-ring: fluoro rubber		
Connection	+, -		
Case structure	Drip-proof structure		
Approval	CE		
Weight ^{*1}	Approx. 350 g (approx. 320 g) (based on head type)		

※ 1: The weight includes packaging. The weight in paranthesis is for unit only.
※ F.S.(Full Scale): It is rated pressure range.
※ Environment resistance is rated at no freezing or condensation.

■ Dimensions

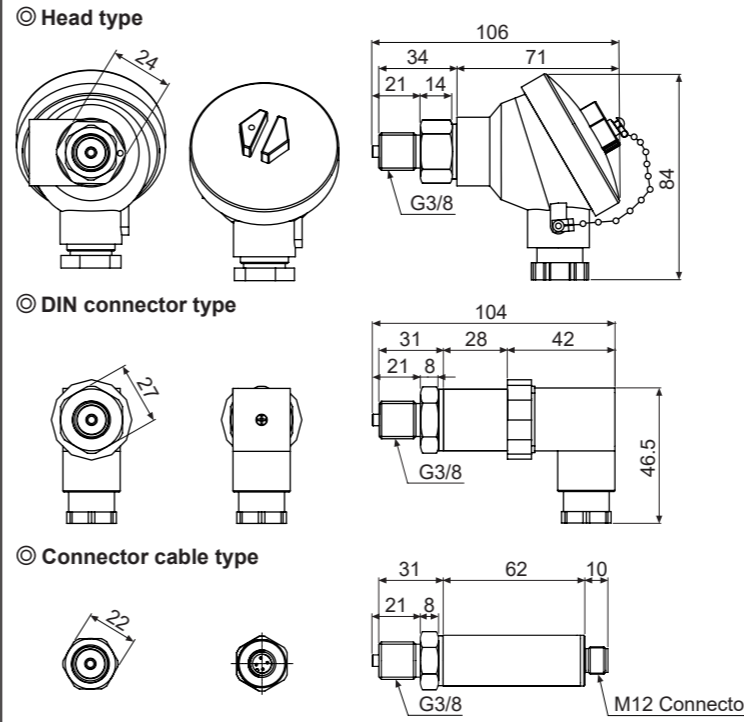

※ The standard pressure port for above is G3/8.

■ Connection Cable (sold separately)

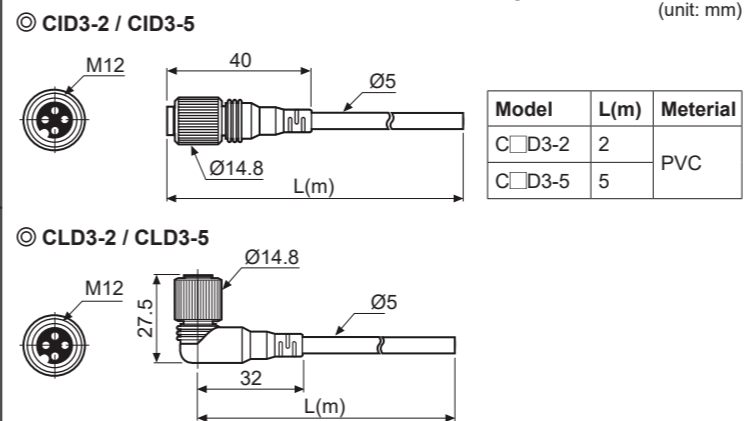

■ Connections

Head type	DIN connector type		Connector cable type	
Pin	Pin	Function	Pin	Function
+	1	+	1	+
-	2	-	2	N-C
	3	N-C	3	F.G.
		F.G.	4	-

※ In case of head type, remove the top cover.

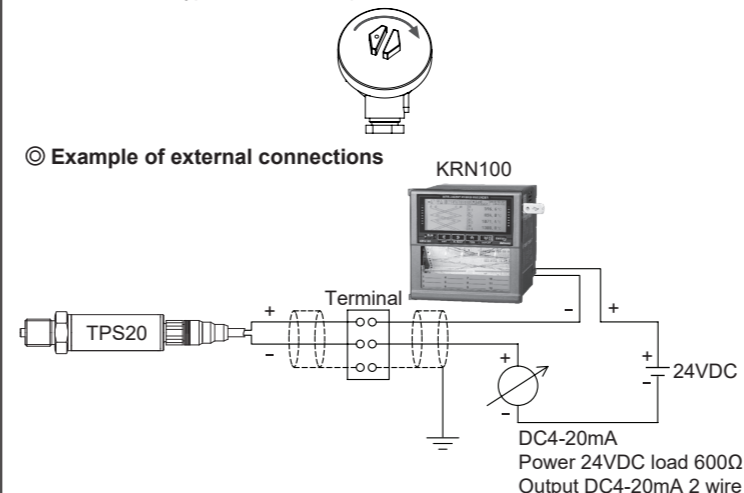

■ Troubleshooting

Error	Troubleshooting
No outputs	Check the power supply. Check the polarity (+, -) when wiring cable. Check the connection part.
Abnormally fluctuating output	Check the power supply. Check the supplied pressure. Check the pressure line.
Out of zero point output value	Check the power supply. Check the load resistive value of current output type for a receiver is over 600Ω. Check the measuring point and transmission distance. Check the line resistance is below 600Ω.

■ Cautions during Use

1. When installing the unit on pipe line, use the hexagon part of connections not to turn the unit with a pipe wrench. Do not use the unit with strong vibrations.
2. The unit is manufactured with precision. If you drop or shock the unit, it may lose the function. Please treat the unit carefully.
3. Store the unit at the place without moisture, dust, and vibration.
4. This product which does not have drive part at sensing part does not need to be repaired. Even though inside of pressure pipe is normally clean, it needs to take maintenance once a year as below instructions.
 - ① Check the broken status of outside.
 - ② Check the pressure slot, cleanliness inside, and corrosion state.
 - ③ Short each terminal and check the insulation resistance between the case and power. (at 100VDC, over 10MΩ)
 - ④ Check zero, span adjustment and linearity by pressure standards.
5. When removing a sensor for maintenance, follow the below instructions.
 - ① Replace an O-ring which is used once.
 - ② Be sure that diaphragm part is not damaged.
6. In case of head type for connecting the power, use a crimp terminal. (M3.5, Max. 7.2mm)
7. The connection of this unit should be separated from the power line and high voltage line in order to prevent inductive noise.
8. Install a power switch or a circuit breaker to supply or cut off the power.
9. Connect the power with the crimp terminals.
10. Switch or circuit breaker should be installed nearby users for convenient control.
11. Do not use the unit near the high frequency instruments (high frequency welding machine & sewing machine, large capacity SCR controller).
12. The unit cannot be repaired due to disassembled structure.
13. The unit is fixed with bolt and nut at the both sides of case.
Do not press excessive load (approx. 300kg/cm²), or it may cause damage to the unit.
14. Do not pull the cables with over 30N of tension force.
15. Tighten the cable connection part firmly not to enter water to the cable.
16. Installation environment.
 - ① Indoor / Outdoor
 - ② Altitude max. 2,000 m
 - ③ Pollution degree 2
 - ④ Installation category II

※ We are not responsible for any damages and claims for careless. Must read the cautions for your safety and using.
※ If there are any problems with the unit, contact the head office or A/S center.
※ Failure to follow these instructions may result in product damage.

■ Major Products

- Photoelectric Sensors
- Fiber Optic Sensors
- Door Sensors
- Door Side Sensors
- Area Sensors
- Proximity Sensors
- Pressure Sensors
- Rotary Encoders
- Connectors/Sockets
- Switching Mode Power Supplies
- Control Switches/Lamps/Buzzers
- I/O Terminal Blocks & Cables
- Stepper Motors/Drivers/Motion Controllers
- Graphic/Logic Panels
- Field Network Devices
- Laser Marking System(Fiber, Co., Nd: YAG)
- Laser Welding/Cutting System
- Temperature Controllers
- Temperature/Humidity Transducers
- SSRs/Power Controllers
- Counters
- Timers
- Panel Meters
- Tachometer/Pulse(Rate) Meters
- Display Units
- Sensor Controllers
- Recorders
- Indicators
- Converters
- Controllers
- Thyristor Units
- Pressure Transmitters
- Temperature Transmitters

Autonics Corporation
http://www.autonics.com

HEADQUARTERS:
18, Bansong-ro 513beon-gil, Haeundae-gu, Busan, South Korea, 48002
TEL: 82-51-519-3232
E-mail: sales@autonics.com